



# MANUFACTURER'S ELS PRODUCT DECLARATION FOR ESB NETWORKS FORM NC7-03-R1

ESB Networks DAC requires the information requested on this form to manage your electricity supply connection. As the Distribution System Operator, this information is also required to enable ESB Networks DAC to manage the electricity network. The data controller is ESB Networks DAC. Please refer to our privacy policy at <https://esbnetworks.ie/privacy>

All mandatory requirements in this form are as those required by ESB Networks Standard 'Conditions Governing the Connection and Operation of Export Limiting Schemes' (DOC-250221-GBT)

'Conditions Governing the Connection and Operation of Export Limiting Schemes' (DOC-250221-GBT) defines the technical design requirements for Export Limitation Schemes which limit the net site export to below an agreed maximum and are installed on the Customer's side of the Connection Point.

While DOC-250221-GBT does not describe a type test procedure, it does describe a number of system requirements. This document describes how the ELS product (outlined in Part 1 below) performs relative to key ESB Networks ELS requirements.

**Please complete Parts 1 to 9 below**

## PART 1: PRODUCT DETAILS

Name of Product: HS2 Series Energy Storage System	Model No.: HS2-3K/3.6K/4K/4.6K/5K/6K-S2(Single-phase) HS2-3K/3.6K/4K/4.6K/5K/6K-S2-X(Single-phase) HS2-3K/3.6K/4K/4.6K/5K/6K-S2-X WiFi(Single-phase)
Manufacturer: SAJ	Make: China HS2-3K/3.6K/4K/4.6K/5K/6K-S2-X 4G(Single-phase) HS2-6K-S2-IE-X WiFi,HS2-6K-S2-IE-X 4G(Single-phase) HS2-5K-S2-B-X,HS2-5K-S2-B-X WiFi,HS2-5K-S2-B-X 4G

**Where Manufacturer's ESB Networks ELS Product Declaration Form is unavailable an Export Limiting Relay shall be installed as per ESB Networks Standard 'Conditions Governing the Connection and Operation of Export Limiting Schemes' (DOC-250221-GBT)**

## PART 2: DESCRIPTION OF OPERATION

ESB Networks ELS Requirement: *A description of the scheme, its settings, and a single line diagram shall be permanently displayed on site.*

When installed, the ELS product (as outlined in Part 1) operates as described below:

Please insert details of operation below or if attached as PDF to this form tick here:

## PART 3: POWER QUALITY REQUIREMENTS

**ESB Networks ELS Requirements:**

Where the ELS product (as outlined in Part 1) relies on power electronics (e.g. Converters etc) to control the load it shall also provide information demonstrating compliance with the harmonics standards ([I.S. EN 61000-3-2](#) and/or [I.S. EN 61000-3-12](#)) or provide data on the harmonic currents produced in accordance with the format in the Distribution Code i.e. individual harmonic current and Total Harmonic Distortion.

It is necessary to confirm the ELS product(as outlined in Part 1) complies with harmonic standards cited in the Distribution Code and product standards cited in <a href="#">I.S. EN 50549-1</a> .	Yes <input checked="" type="checkbox"/> No <input type="checkbox"/>
--	---

The Manufacturer (as outlined in Part 1) confirms that the ELS product (as outlined in Part 1) complies with the requirements of the harmonics standards listed above or that the harmonic data has been provided.

## PART 4: SYSTEM SCHEMATIC

The ELS product (as outlined in Part 1) is formed of the following main elements:

Document the main elements and provide a system schematic or if attached as PDF to this form tick here:

1. Main elements:
  - 1.HS2 Series Energy Storage System(Single-phase)
  - 2.Power Sensor: DDSU666(Used for Single-phase inverter)

---

2. System Schematic

## PART 5: COMPONENT INTERCONNECTION/FAILSAFE OPERATION

**ESB Networks ELS Requirements:** The ELS product (as outlined in Part 1) may be formed of discrete units or integrated into a single packaged scheme. Where discrete units are used, they should preferably be interconnected using metallic or fibre optic cables. Other means of connection such as Wi-Fi are not deemed 'Fail Safe' and require installation of Export Limiting Relay. Irrespective of the media used for interconnecting between the discrete units, if the communication path fails the generation output shall be reduced to the allowed MEC within 5 seconds time to prevent the Agreed Export Capacity from being exceeded.

Description of the fail-safe functionality (Interruption of sensor signals, disconnection of load, loss of power, internal fault detection etc.)

5.1 Describe Component Interconnection here:

Text or diagram or if attached as PDF to this form tick here:

### 5.2 System Fail Safe Test Results:

Please indicate appropriate answer

No.	Test	System Response	Time <5s	Pass
1	Remove Power Supply to PMU	The PMU draws power from the grid, a power failure means a grid failure, the inverter is disconnected from the grid.	Yes <input checked="" type="checkbox"/> No <input type="checkbox"/>	Yes <input checked="" type="checkbox"/> No <input type="checkbox"/>
2	Remove Power Supply to CU	The CU is integrated in the inverter, remove power supply to the inverter, the inverter is disconnected from the grid and stop working.	Yes <input checked="" type="checkbox"/> No <input type="checkbox"/>	Yes <input checked="" type="checkbox"/> No <input type="checkbox"/>
3	Remove Power Supply to all Energy Source Units	The Power Supply Failure to Energy Source Units means the PV module and storage devices stop working.	Yes <input checked="" type="checkbox"/> No <input type="checkbox"/>	Yes <input checked="" type="checkbox"/> No <input type="checkbox"/>
4	Remove power Supply to all DCUs	N/A, The Inverter does not control the local loads.	Yes <input type="checkbox"/> No <input type="checkbox"/>	Yes <input type="checkbox"/> No <input type="checkbox"/>
5	Remove Power Supply to all Communication Hub Switches	N/A, There are no communication hubs switches in the system.	Yes <input type="checkbox"/> No <input type="checkbox"/>	Yes <input type="checkbox"/> No <input type="checkbox"/>
6	Unplug PMU- CU Communications Cable	The inverter will reduce power to a predefined safe range and displays a communication fault.	Yes <input checked="" type="checkbox"/> No <input type="checkbox"/>	Yes <input checked="" type="checkbox"/> No <input type="checkbox"/>
7	Unplug CU – ESIU Communications Cable (at ESIU end)	N/A, CU and ESIU are both integrated in the inverter.	Yes <input type="checkbox"/> No <input type="checkbox"/>	Yes <input type="checkbox"/> No <input type="checkbox"/>
8	Unplug all ESIU –Communication Cables in turn	N/A, There is no communication with the energy source Units.	Yes <input type="checkbox"/> No <input type="checkbox"/>	Yes <input type="checkbox"/> No <input type="checkbox"/>
9	Unplug CU – DCU Comms. Cable for each DCU unit (at DCU end)	N/A, There is no communication with the local loads.	Yes <input type="checkbox"/> No <input type="checkbox"/>	Yes <input type="checkbox"/> No <input type="checkbox"/>
10	Unplug DCU – Load Comms cable	N/A, There is no communication with the local loads.	Yes <input type="checkbox"/> No <input type="checkbox"/>	Yes <input type="checkbox"/> No <input type="checkbox"/>

The purpose of the 'Fail Safe' Tests is to ensure that if any part of the ELS fail, the exported power does not exceed the MEC by more than 5% for more than 5 seconds.

It is a fixed requirement that at no time during the 'Fail Safe' sequence shall the exported power rise above the MEC by more than 5% for more than 5 seconds.

## PART 6: ACCURACY AND RESPONSE TIME

ESB Networks ELS requirements:

The overall accuracy of the ELS product (as outlined in Part 1) with regard to measurement and control of MEC shall be determined by the manufacturer of the system and published within its operating manual. In carrying out the functional tests these tolerances shall be taken into account.

Functional testing – Injection testing

Export limit conditions can be simulated by temporarily connecting the PMU to a calibrated injection test set.

When using an injection test set, there is no feedback loop between the ELS product (as outlined in Part 1) and the injection test set. This has two significant implications for the test process:

1. As soon as the ELS begins to operate, because it sees no corresponding decrease in export levels, the control loop continues running until the Energy Source Units output is reduced to the programmed export capacity or below.
2. To ensure that the ELS is reacting by the correct amount and within an acceptable time period, a step change needs to be applied by the test set to the PMU.

The following Step Change test sequence shall be performed:

Please indicate appropriate answer

No.	Test	Step Change Final Value	Outcome	Pass / Fail
1.	Step change A 95% to 105%	Export = 105% of programmed export limit value	At 95% Voltage	Pass <input checked="" type="checkbox"/> Fail <input type="checkbox"/>
			At 100% Voltage	Pass <input checked="" type="checkbox"/> Fail <input type="checkbox"/>
			At 110% Voltage	Pass <input checked="" type="checkbox"/> Fail <input type="checkbox"/>
	Step change A 95% to 110%	Export = 105% of programmed export limit value	At 95% Voltage	Pass <input checked="" type="checkbox"/> Fail <input type="checkbox"/>
			At 100% Voltage	Pass <input checked="" type="checkbox"/> Fail <input type="checkbox"/>
			At 110% Voltage	Pass <input checked="" type="checkbox"/> Fail <input type="checkbox"/>
	Step change A 95% to 120%	Export = 105% of programmed export limit value	At 95% Voltage	Pass <input checked="" type="checkbox"/> Fail <input type="checkbox"/>
			At 100% Voltage	Pass <input checked="" type="checkbox"/> Fail <input type="checkbox"/>
			At 110% Voltage	Pass <input checked="" type="checkbox"/> Fail <input type="checkbox"/>
2.	Step change B 95% to 105%	Export = 110% of programmed export limit value	At 95% Voltage	Pass <input checked="" type="checkbox"/> Fail <input type="checkbox"/>
			At 100% Voltage	Pass <input checked="" type="checkbox"/> Fail <input type="checkbox"/>
			At 110% Voltage	Pass <input checked="" type="checkbox"/> Fail <input type="checkbox"/>
	Step change B 95% to 110%	Export = 110% of programmed export limit value	At 95% Voltage	Pass <input checked="" type="checkbox"/> Fail <input type="checkbox"/>
			At 100% Voltage	Pass <input checked="" type="checkbox"/> Fail <input type="checkbox"/>
			At 110% Voltage	Pass <input checked="" type="checkbox"/> Fail <input type="checkbox"/>
	Step change B 95% to 120%	Export = 110% of programmed export limit value	At 95% Voltage	Pass <input checked="" type="checkbox"/> Fail <input type="checkbox"/>
			At 100% Voltage	Pass <input checked="" type="checkbox"/> Fail <input type="checkbox"/>
			At 110% Voltage	Pass <input checked="" type="checkbox"/> Fail <input type="checkbox"/>
3.	Step change C 95% to 105%	Export = 120% of programmed export limit value	At 95% Voltage	Pass <input checked="" type="checkbox"/> Fail <input type="checkbox"/>
			At 100% Voltage	Pass <input checked="" type="checkbox"/> Fail <input type="checkbox"/>
			At 110% Voltage	Pass <input checked="" type="checkbox"/> Fail <input type="checkbox"/>
	Step change C 95% to 110%	Export = 120% of programmed export limit value	At 95% Voltage	Pass <input checked="" type="checkbox"/> Fail <input type="checkbox"/>
			At 100% Voltage	Pass <input checked="" type="checkbox"/> Fail <input type="checkbox"/>
			At 110% Voltage	Pass <input checked="" type="checkbox"/> Fail <input type="checkbox"/>
	Step change C 95% to 120%	Export = 120% of programmed export limit value	At 95% Voltage	Pass <input checked="" type="checkbox"/> Fail <input type="checkbox"/>
			At 100% Voltage	Pass <input checked="" type="checkbox"/> Fail <input type="checkbox"/>
			At 110% Voltage	Pass <input checked="" type="checkbox"/> Fail <input type="checkbox"/>

The procedure for performing the test is as follows:

- Initially apply 100% of nominal voltage and inject current (at unity power factor) to mimic an exported Active Power equivalent to 95% of the export limit setting. Check that the ELS product(as outlined in Part 1) does not operate.
- Step up the current to give an export Active Power equivalent to 105% of the export Active Power limit (for Test A), Check that change in export level is "seen" by the PMU.
- Check that the Active Power exported by the generation reduces to a value at least 5% below the export limit setting within the specified reaction time. The test shall be repeated at the maximum statutory voltage (i.e. at 110% of nominal voltage at LV) and also at the minimum voltage limit (i.e. 90% of nominal voltage for LV connections).
- All the above tests shall also be repeated for step increases from 95% to 110% of the export limit and from 95% to 120% of the export limit as detailed above.

When injection testing is complete, the correct orientation of any current monitoring connections (including CT orientations) which may have been removed for the test shall be checked and verified as correct.

## PART 6A: CONFIRMATION OF OPERATION OF ELS TO LIMIT EXPORT AS REQUIRED

ESB Networks ELS requirements:

The ELS product(as outlined in Part 1) shall detect an excursion and reduce the export to the MEC or less, within 5 seconds.

Under normal operating conditions, the ELS product (as outlined in Part 1) response time is less than 5 seconds.

Under loss of communications, or loss of power to any part of the ELS product (as outlined in Part 1), response time is less than 5 seconds.

Operation of above is confirmed	Yes <input checked="" type="checkbox"/> No <input type="checkbox"/>
Operating Manual is available	Yes <input checked="" type="checkbox"/> No <input type="checkbox"/>
The settings applied to ELS product(as outlined in Part 1) have taken account of the published (DOC-250221-GBT) tolerances to ensure the required export limits and voltage limits shall be maintained.	Yes <input checked="" type="checkbox"/> No <input type="checkbox"/>

## PART 7: PASSWORD PROTECTION

ESB Networks ELS requirement:

Once installed and commissioned, the ELS product(as outlined in Part 1) settings shall not be capable of being readily altered by the Customer and shall only be changed with the written agreement of ESB Networks.	Yes <input checked="" type="checkbox"/> No <input type="checkbox"/>
All settings of the ELS product(as outlined in Part 1) are password protected and cannot be altered by the customer.	Yes <input checked="" type="checkbox"/> No <input type="checkbox"/>

## PART 8: INSTALLATION REQUIREMENTS

ELS Installation Requirements for ELS Product(as outlined in Part 1):

Please insert installation requirements or if attached as PDF to this form tick here:

## PART 9: MANUFACTURERS ELS PRODUCT DECLARATION FOR ESB NETWORKS

ESB Networks ELS requirement: Once installed and commissioned, the scheme settings shall not be capable of being readily altered by the Customer and shall only be changed with the written agreement of ESB Networks.

The ELS product (as outlined in Part 1) complies with the 'Conditions Governing the Connection and Operation of Export Limiting Schemes' (DOC-250221-GBT) when installed and commissioned in accordance with the product documentation.

Manufacturer's (as outlined in Part 1) Representative Details

Representative Name: Pan guangquan

Title: Certified Engineer

Email: guangquan.pan@saj-electric.com

Contact Telephone Number: 02066608528

Signature: Guangquan.Pan

Date: 12th July 2024

**PLEASE REMEMBER!**  
DON'T BUILD UNDER OR NEAR ELECTRICITY WIRES  
**STAY SAFE STAY CLEAR**  
**OF ELECTRICITY WIRES**  
ESB NETWORKS DAC



ESB Networks DAC

Directors: Marguerite Sayers (Chairperson),  
Nicholas Tarrant, Caroline Spillane, Ian Talbot,  
Michael Nolan.

Registered office: Three Gateway, East Wall Road,  
Dublin 3, D03 R583, Ireland.

Registered in Ireland No. 465172



广州三晶电气股份有限公司

Guangzhou Sanjing Electric Co., Ltd.

Tel : 400-159-0088 Fax : 020-66608589

Web : www.saj-electric.cn / www.saj-electric.com

地址 : 广州高新技术产业开发区科学城荔枝山路9号三晶创新园

Add: SAJ Innovation Park, No.9, Lizhishan Road, Science City, Guangzhou High-tech Zone, Guangdong, P.R.China.

# Manufacturer's Declaration

Power Export Limitation for Grid-connected PV Inverter

ESB Company Standard NC7-03-R1

## Energy Storage System Types:

HS2-3K/3.6K/4K/4.6K/5K/6K-S2;

HS2-3K/3.6K/4K/4.6K/5K/6K-S2-X;

HS2-3K/3.6K/4K/4.6K/5K/6K-S2-X WiFi;

HS2-3K/3.6K/4K/4.6K/5K/6K-S2-X 4G;

HS2-5K-S2-B, HS2-5K-S2-B-X, HS2-5K-S2-B WiFi, HS2-5K-S2-B 4G;

HS2-6K-S2-IE-X WiFi, HS2-6K-S2-IE-X 4G;

## Power Sensor:

DDSU666 Single-Phase Meter

## Statement:

The Energy Storage Systems mentioned above, when installed with a power sensor, are as a system compliant to the technical regulations set forth in the ESB Company Standard NC7-03-R1. This declaration applies to installations connected to the low voltage grid where the total Energy Storage System Power Export capability must be reduced to meet the contracted Maximum Export Capability.

**Guangzhou Sanjing Electric Co., Ltd.**

Signed: *Guangquan.Pan* Date: 12th July 2024

## Description of Operation:

The Export Limiting System(ELS) consists of PV modules, Energy Storage System, loads and a Meter. The AC side of the Energy Storage System is connected to the Utility Grid through the Utility meter; the Meter is mounted behind the Utility Meter and establishes communication with the Energy Storage System through RS485&RJ45 connection; the DC side of the Energy Storage System is connected to the PV modules. The following is a typical wiring diagram of the ELS.

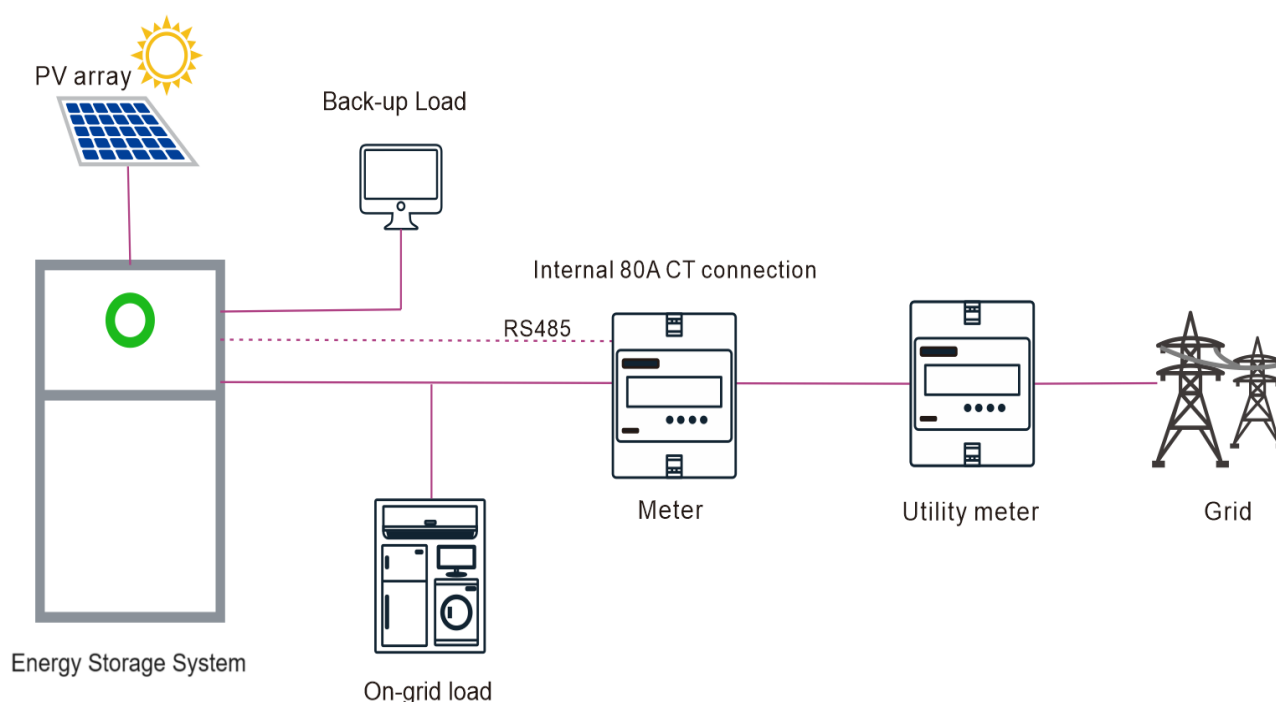

## Fail Safe Operation:

The Energy Storage System communicates with the Meter through RS485 and polling to receive data. And the Energy Storage System compares the export power and import power data with the ELS limit value to control the power balance of the plant. When the Energy Storage System does not receive the Meter data, Energy Storage System will enter the fault state and stop power transmission within 5 seconds.