



# TEST REPORT



## EN 50549-1:2019

**Requirements for generating plants to be connected in parallel  
with distribution networks - Part 1-1:  
Connection to a LV distribution network - Generating plants up  
to and including Type B**

<b>Report reference number</b> .....	<b>PVIR200511N080-2</b>
Date of issue .....	2020-12-25
Total number of pages .....	153
<b>Testing laboratory name</b> .....	<b>Bureau Veritas Shenzhen Co., Ltd. Dongguan Branch</b>
Address .....	No. 96, Guantai Road (Houjie Section), Houjie Town, Dongguan City, Guangdong Province, 523942, People's Republic of China
Accreditation .....	  Certificate # 2951.01
<b>Applicant's name</b> .....	<b>Shenzhen SOFARSOLAR Co., Ltd.</b>
Address .....	401, Building 4, AnTongDa Industrial Park, District 68, XingDong Community, XinAn Street, BaoAn District, Shenzhen, China
<b>Test specification</b>	
Standard.....	EN 50549-1:2019 with deviations according the national network and system protection for Ireland.
Test Report Form No. ....	EN 50549-1 VER.0
TRF Originator .....	Bureau Veritas Shenzhen Co., Ltd. Dongguan Branch
Master TRF .....	Dated 2019-12-11
<b>Test item description</b> .....	<b>Solar Grid-tied Inverter</b>
Trademark.....	
Model / Type .....	SOFAR 15KTLX-G3, SOFAR 17KTLX-G3, SOFAR 20KTLX-G3, SOFAR 22KTLX-G3, SOFAR 24KTLX-G3
<small>This report is governed by, and incorporates by reference, CPS Conditions of Service as posted at the date of issuance of this report at <a href="http://www.bureauveritas.com/home/about-us/our-business/cps/about-us/terms-conditions">http://www.bureauveritas.com/home/about-us/our-business/cps/about-us/terms-conditions</a> and is intended for your exclusive use. Any copying or replication of this report to or for any other person or entity, or use of our name or trademark, is permitted only with our prior written permission. This report sets forth our findings solely with respect to the test samples identified herein. The results set forth in this report are not indicative or representative of the quality or characteristics of the lot from which a test sample was taken or any similar or identical product unless specifically and expressly noted. Our report includes all of the tests requested by you and the results thereof based upon the information that you provided to us. Measurement uncertainty is only provided upon request for accredited tests. You have 60 days from date of issuance of this report to notify us of any material error or omission caused by our negligence or if you require measurement uncertainty; provided, however, that such notice shall be in writing and shall specifically address the issue you wish to raise. A failure to raise such issue within the prescribed time shall constitute your unqualified acceptance of the completeness of this report, the tests conducted and the correctness of the report contents.</small>	

Ratings .....	SOFAR 15KTLX-G3	SOFAR 17KTLX-G3	SOFAR 20KTLX-G3	SOFAR 22KTLX-G3	SOFAR 24KTLX-G3
Input DC voltage [V]..... :	Max. 1100Vd.c.				
MPP DC voltage range [V]..... :	140-1000Vd.c.				
Input DC current [A] .....	26,0A / 26,0A				
Isc PV [A] .....	36,0A / 36,0A				
Output AC voltage [V] .....	380/400Va.c., 3W+N+PE; 50/60Hz				
Rated Output AC current [A]..... :	21,7	24,6	29,0	31,9	34,8
Max. Output AC current [A]..... :	23,9	27,1	31,9	35,1	38,3
Rated Output power [kW] .....	15,0	17,0	20,0	22,0	24,0
Max Output power [kVA]..... :	16,5	18,7	22,0	24,2	26,4



<b>Testing Location</b> .....	<b>Bureau Veritas Shenzhen Co., Ltd. Dongguan Branch</b>
Address .....	No. 96, Guantai Road (Houjie Section), Houjie Town, Dongguan City, Guangdong Province, 523942, People's Republic of China
Tested by (name and signature).....	Lukes Lin 
Approved by (name and signature).....	James Huang 
<b>Manufacturer's name</b> .....	<b>Shenzhen SOFARSOLAR Co., Ltd.</b>
Manufacturer address .....	401, Building 4, AnTongDa Industrial Park, District 68, XingDong Community, XinAn Street, BaoAn District, Shenzhen, China
<b>Factory's name</b> .....	<b>Dongguan SOFAR SOLAR Co.,Ltd.</b>
Factory address .....	1F - 6F, Building E, No. 1 JinQi Road, Bihu Industrial Park, Wulian Village, Fenggang Town, Dongguan City

<b>Document History</b>			
<b>Date</b>	<b>Internal reference</b>	<b>Modification / Change / Status</b>	<b>Revision</b>
2020-12-25	Lukes Lin	Initial report was written	0
Supplementary information:			



**This Test Report consists of the following documents:**

1. Test Report
  - 4.4 Normal operating range
  - 4.5 Immunity to disturbances
  - 4.6 Active response to frequency deviation
  - 4.7 Power response to voltage variations and voltage changes
  - 4.8 EMC and power quality
  - 4.9 Interface protection
  - 4.10 Connection and starting to generate electrical power
  - 4.11 Ceasing and reduction of active power on set point
  - 4.13 Requirements regarding single fault tolerance of interface protection system and interface switch
2. Annex No. 1 – Pictures of the unit
3. Annex No. 2 – Test equipment list

Copy of marking plate

**SOFAR** Solar Grid-tied Inverter  
SOLAR

Model No:	SOFAR 15KTLX-G3
Max.DC Input Voltage	1100V
Operating MPPT Voltage Range	140~1000V
Max. Input Current	26A/26A
Max. PV Isc	36A/36A
Nominal Grid Voltage	3/N/PE,380/400V
Max. Output Current	3x23.9A
Nominal Grid Frequency	50/60Hz
Nominal Output Power	15000W
Max. Output Power	16500VA
Power Factor	1(adjustable+/-0.8)
Ingress Protection	IP65
Operating Temperature Range	-30°C~+60°C
Protective Class	Class I

Made in China

Manufacturer : Shenzhen SOFARSOLAR Co.,Ltd.  
Address : 401, Building 4, AnTongDa Industrial Park,  
District 68, XingDong Community,XinAn Street,  
BaoAn District, Shenzhen, China  
VDE0126-1-1,VDE-AR-N4105,G99,IEC61727  
IEC62116,UTE C15-712-1,AS4777



**SOFAR** Solar Grid-tied Inverter  
SOLAR

Model No:	SOFAR 17KTLX-G3
Max.DC Input Voltage	1100V
Operating MPPT Voltage Range	140~1000V
Max. Input Current	26A/26A
Max. PV Isc	36A/36A
Nominal Grid Voltage	3/N/PE,380/400V
Max. Output Current	3x27.1A
Nominal Grid Frequency	50/60Hz
Nominal Output Power	17000W
Max. Output Power	18700VA
Power Factor	1(adjustable+/-0.8)
Ingress Protection	IP65
Operating Temperature Range	-30°C~+60°C
Protective Class	Class I

Made in China

Manufacturer : Shenzhen SOFARSOLAR Co.,Ltd.  
Address : 401, Building 4, AnTongDa Industrial Park,  
District 68, XingDong Community,XinAn Street,  
BaoAn District, Shenzhen, China  
VDE0126-1-1,VDE-AR-N4105,G99,IEC61727  
IEC62116,UTE C15-712-1,AS4777



**SOFAR** Solar Grid-tied Inverter

Model No:	SOFAR 20KTLX-G3
Max.DC Input Voltage	1100V
Operating MPPT Voltage Range	140~1000V
Max. Input Current	26A/26A
Max. PV Isc	36A/36A
Nominal Grid Voltage	3/N/PE,380/400V
Max.Output Current	3x31.9A
Nominal Grid Frequency	50/60Hz
Nominal Output Power	20000W
Max.Output Power	22000VA
Power Factor	1(adjustable+/-0.8)
Ingress Protection	IP65
Operating Temperature Range	-30°C~+60°C
Protective Class	Class I
Made in China	

Manufacturer : Shenzhen SOFARSOLAR Co.,Ltd.  
 Address : 401, Building 4, AnTongDa Industrial Park,  
 District 68, XingDong Community,XinAn Street,  
 BaoAn District, Shenzhen, China  
 VDE0126-1-1,VDE-AR-N4105,G99,IEC61727  
 IEC62116,UTE C15-712-1,AS4777



**SOFAR** Solar Grid-tied Inverter

Model No:	SOFAR 22KTLX-G3
Max.DC Input Voltage	1100V
Operating MPPT Voltage Range	140~1000V
Max. Input Current	26A/26A
Max. PV Isc	36A/36A
Nominal Grid Voltage	3/N/PE,380/400V
Max.Output Current	3x35.1A
Nominal Grid Frequency	50/60Hz
Nominal Output Power	22000W
Max.Output Power	24200VA
Power Factor	1(adjustable+/-0.8)
Ingress Protection	IP65
Operating Temperature Range	-30°C~+60°C
Protective Class	Class I
Made in China	

Manufacturer : Shenzhen SOFARSOLAR Co.,Ltd.  
 Address : 401, Building 4, AnTongDa Industrial Park,  
 District 68, XingDong Community,XinAn Street,  
 BaoAn District, Shenzhen, China  
 VDE0126-1-1,VDE-AR-N4105,G99,IEC61727  
 IEC62116,UTE C15-712-1,AS4777



**SOFAR** Solar Grid-tied Inverter  
SOLAR

Model No:	SOFAR 24KTLX-G3
Max.DC Input Voltage	1100V
Operating MPPT Voltage Range	140~1000V
Max. Input Current	26A/26A
Max. PV Isc	36A/36A
Nominal Grid Voltage	3/N/PE,380/400V
Max. Output Current	3x38.3A
Nominal Grid Frequency	50/60Hz
Nominal Output Power	24000W
Max. Output Power	26400VA
Power Factor	1(adjustable+/-0.8)
Ingress Protection	IP65
Operating Temperature Range	-30°C~+60°C
Protective Class	Class I
Made in China	

Manufacturer : Shenzhen SOFARSOLAR Co.,Ltd.  
 Address : 401, Building 4, AnTongDa Industrial Park,  
 District 68, XingDong Community,XinAn Street,  
 BaoAn District, Shenzhen, China  
 VDE0126-1-1,VDE-AR-N4105,G99,IEC61727  
 IEC62116,UTE C15-712-1,AS4777





**General product information:**

The Solar Grid-tied Inverter converts DC voltage into AC voltage.

The DC input of Solar Grid-tied Inverter can be supplied from PV array.

The Solar Grid-tied Inverter is a three-phase type .

The unit is providing EMC filtering at the output toward mains. The unit does not provide galvanic separation from input to output (transformerless). The output is switched off redundant by the high power switching bridge and a two relays. This assures that the opening of the output circuit will also operate in case of one error.

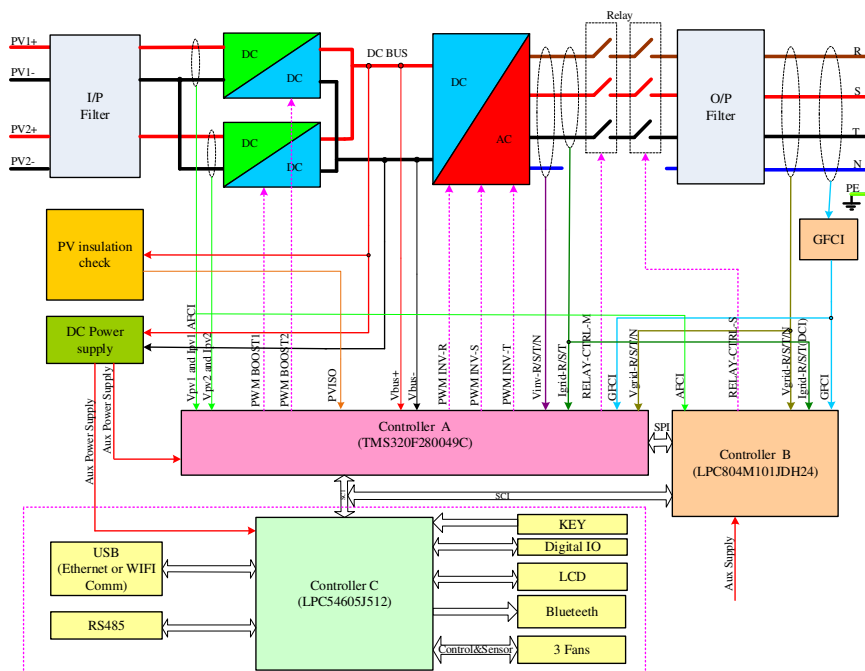
**Description of the electrical circuit:**

The internal control is redundant built. It consists of Main DSP (U30) and slave DSP(U23).

The Main DSP (U30) can control the relays, measures voltage, and frequency, AC current with injected DC, insulation resistance and residual current, In addition it tests the array insulation resistance and the RCMU circuit before each start up.

The slave DSP (U23) is using for detect residual current, also can open the relays independently and communicate with Main DSP (U30).

The unit provides two relays in series on Line and Neutral conductors. When single-fault applied to one relay, alarm an error code in display panel, another redundant relay provides basic insulation maintained between the PV array and the mains. All the relays are tested before start up. Both controllers(Main DSP (U30), Slave DSP (U23) can open the relays.



**Figure 1 – Block diagram**

**The product was tested on:**

Hardware version: V101

Software version: V010000

**Model difference:**

The models SOFAR 15KTLX-G3, SOFAR 17KTLX-G3, SOFAR 20KTLX-G3, SOFAR 22KTLX-G3 and SOFAR 24KTLX-G3 are use the identical hardware platform, control unit, control system and software except the output power derated by software and in following table descripts for different.

	SOFAR 15KTLX-G3	SOFAR 17KTLX-G3	SOFAR 20KTLX-G3	SOFAR 22KTLX-G3	SOFAR 24KTLX-G3
Thin-film capacitor of BUS	4pcs (110uF, 550V)	6pcs (110uF, 550V)			
INV IGBT (Q60, Q67, Q71 Q72, Q75, Q76)	6pcs 40A, 1200V	6pcs 75A, 1200V			
External Fan	1		2		

**General remarks:**

The test results presented in this report relate only to the object(s) tested.

This document may be published or passed on in full only. Extraction of parts needs the written permission of Bureau Veritas Consumer Products Services GmbH.

"(see Annex #)" refers to additional information appended to the report.

"(see appended table)" refers to a table appended to the report.

Throughout this report a comma is used as the decimal separator.

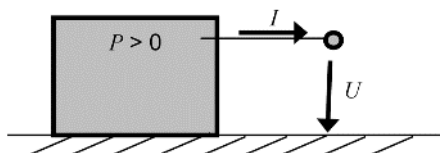
The following suffixes are used for variables in tables and figures:

- "P<sub>n</sub>" for the nominal active power:  
 $P_n = U_n \times I_n \times \cos \varphi_n$  (single-Phase);  $P_n = \sqrt{3} U_n \times I_n \times \cos \varphi_n$  (three-Phase)
- "P<sub>M</sub>" for the momentary power
- "(c)" for over-excited
- "(i)" for under-excited

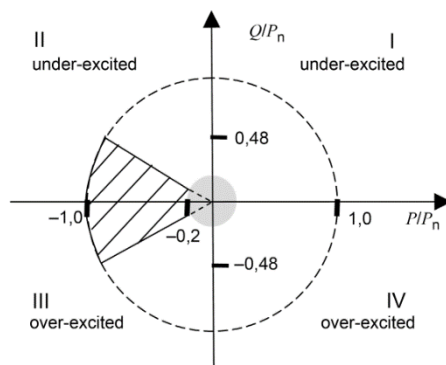
**Active and reactive power:**

The regarded system of the voltage and current vectors is the load view (Figure 2):

- If the inverter feeds to the grid the active power is measured with negative sign. For the sake of reading the document the measured active infeed power has a positive sign



- If the inverter consumes inductive reactive power the reactive power is marked "inductive" or has a positive sign.
- If the inverter consumes capacitive reactive power the reactive power is marked "capacitive" or has a negative sign.



**Figure 2**

<b>Default interface protection settings according EN 50549-1:2019:</b>			
<b>Parameter</b>	<b>Max. disconnection time</b>	<b>Min. operate time</b>	<b>Trip value</b>
Over voltage – stage 1	61 s	0,1 s	230V +15% (264,5 V)
Over voltage – stage 2	0,2 s	0,1 s	230V +25% (287,5 V)
Under voltage – stage 1	5 s	0,1 s	230V -20% (184V)
Under voltage – stage 2	2 s	0,1 s	230V -50% (115V)
Over frequency – stage 1	0,5 s	0,3 s	51,5 Hz
Over frequency – stage 2	0,2 s	0,1 s	52 Hz
Under frequency– stage 1	0,5 s	0,3 s	47,5 Hz
Under frequency– stage 2	0,2 s	0,1 s	47 Hz
Reconnection settings for voltage	$0,85 U_n \leq U \leq 1,10 U_n$		
Connection settings for frequency (Normal operational start-up)	$49,5 \text{ Hz} \leq f \leq 50,1 \text{ Hz}$		
Reconnection settings for frequency (Automatic reconnection after tripping)	$49,5 \text{ Hz} \leq f \leq 50,2 \text{ Hz}$		
Reconnection time	$\geq 60 \text{ s}$		
Active power gradient after reconnection	$10\%P_n/\text{min}$		
Permanent DC-injection	0,5% of rated inverter output current or 20mA		
Loss of mains according EN 62116	Inverter shall disconnect within 2 s.		
<p>The stated currents and voltages are 'true r.m.s.'-values.</p> <p>The voltages in this table are</p> <ul style="list-style-type: none"> <li>- phase-to-neutral in 230 V single phase systems and 230/400 V systems,</li> <li>- phase-to-phase in a multiphase 230 V system.</li> </ul>			
<p>Tolerances on trip values:</p> <ul style="list-style-type: none"> <li>- Voltage: <math>\pm 1\%</math> of <math>U_n</math></li> <li>- Frequency: <math>\pm 0,05 \text{ Hz}</math></li> <li>- Disconnection time : <math>\pm 10\%</math></li> </ul>			

**The following deviations for Ireland have been applied according the EN 50438:2013:**

Parameter	Max. clearance time	Trip setting
<b>Over voltage</b>	0,5s	230V +10% (253V)
<b>Under voltage</b>	0,5s	230V -10% (207V)
<b>Over frequency</b>	0,5s	50Hz +1% (50,5Hz)
<b>Under frequency</b>	0,5s	50Hz -4% (48,0Hz)
An explicit Loss of Mains functionality shall be included. Established methods such as, but not limited to, Rate of Change of Frequency, Vector Shift or Source Impedance Measurement may be used. Where Source Impedance is measured, this shall be achieved by purely passive means, Any implementation which involves the injection of pulses onto the distribution network, shall not be permitted.		
<b>ROCOF (where used)</b>	0,5s	0,4 Hz/s
<b>Vector Shift (where used)</b>	0,5s	6°
Reconnection settings for voltage		$0,89 U_n \leq U \leq 1,10 U_n$
Reconnection settings for frequency		$49,2 \text{ Hz} \leq f \leq 50,05 \text{ Hz}$
Reconnection time		$\geq 60 \text{ s}$
Active power gradient after reconnection		10 % $P_n$ / min

### EN 50549:2019, clause 4: Tests

Clause	Test requirement (According to table C.1)	Result
4.4	Normal operating range	P
4.5	Immunity to disturbances	P
4.6	Active response to frequency deviation	P
4.7	Power response to voltage variations and voltage changes	P
4.8	EMC and power quality	P
4.9	Interface protection	P
4.10	Connection and starting to generate electrical power	P
4.11	Ceasing and reduction of active power on set point	P
4.12	Remote information exchange	N/A
4.13	Requirements regarding single fault tolerance of interface protection system and interface switch	P

### EN 50549-1:2019: Normal operating range

Clause	Test requirement	Test procedure according standard	Result
4.4.2	Power response to over-frequency	EN 50438, Annex D.3.1	P
4.4.3	Power response to under-frequency	G99/1-4, clause A.7.3.2	P
4.4.4	Continuous operating voltage range	EN 50438, Annex D.3.1	P

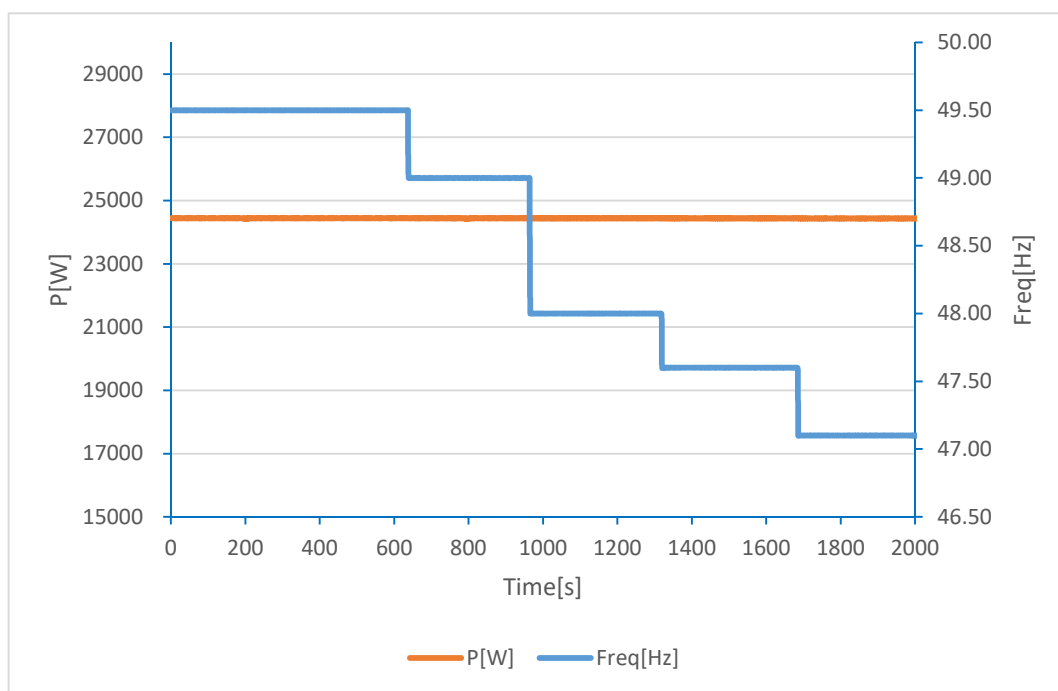
4.4.2 Operating frequency range			P	
4.4.4 Continuous operating voltage range				
Setting values	Over-voltage [V]:		253	
	Under-voltage [V]:		195,5	
	Over-frequency [Hz]:		51,5	
	Under-frequency [Hz]:		47,5	
<ul style="list-style-type: none"> <li>- Test 1: U = 195,5 V; f = 47,5 Hz; P = 1,00 S<sub>n</sub>; cosφ = 1</li> <li>- Test 2: U = 195,5 V; f = 48,5 Hz; P = 1,00 S<sub>n</sub>; cosφ = 1</li> <li>- Test 3: U = 253,0 V; f = 51,5 Hz; P = 1,00 S<sub>n</sub>; cosφ = 1</li> <li>- Test 4: U = 230,0 V; f = 50,0 Hz; Voltage Phase jumps Change +20 derees P = 1,00g S<sub>n</sub>; cosφ = 1</li> <li>- Test 5: U = 230,0 V; f = 50,0 to 50,5 Hz;RoCoF=1Hz/s; P = 1,00 S<sub>n</sub>; cosφ = 1</li> </ul>				
<b>Test result:</b>				
Test sequence	Voltage [V]	Frequency [Hz]	Output power [kW]	Cos φ
Test1	195,71	47,50	22,482	0,9999
Test2	195,74	48,50	22,551	0,9999
Test3	253,05	51,50	24,455	0,9999
Test4	231,61	50,00	24,444	0,9999
Test5	231,64	50,50	24,444	0,9999
<p><b>Note:</b></p> <p>Test method refer clause D.3.1 of EN 50438:2013.</p> <p>During the tests the interface protection was disabled.</p> <p>Operation at reduced power is allowed during test 1, equal to the maximum power that can be supplied on reaching the maximum output current limit (<math>P \geq 0,85 S_n</math>).</p> <p>During the sequence of test 3, automatic adjustment to reduce power in the case of over-frequency was disabled.</p> <p>The tests had been performed on the SOFAR 24KTLX-G3 is valid for the SOFAR 15KTLX-G3, SOFAR 17KTLX-G3, SOFAR 20KTLX-G3 and SOFAR 22KTLX-G3, since it is identical in hardware and software construction except output power derated by software.</p>				



**4.4.3 Minimal requirement for active power delivery at under-frequency**

**P**

**Graph of frequency a) to b) to c) to d) to e):**



**Test result:**

	Switch to:				
5-min mean value (each)	a) 49,50 Hz	b) 49,00 Hz	c) 48,00 Hz	d) 47,60 Hz	e) 47,10 Hz
Frequency [Hz]:	49,50	49,00	48,00	47,60	47,10
Active power [kW]:	24,442	24,441	24,439	24,438	24,436
$\Delta P/P_n$ [%] :	1,840	1,836	1,827	1,824	1,818

**Assessment criterion:**

Test method refer clause A.7.3.2 of G99/1-4

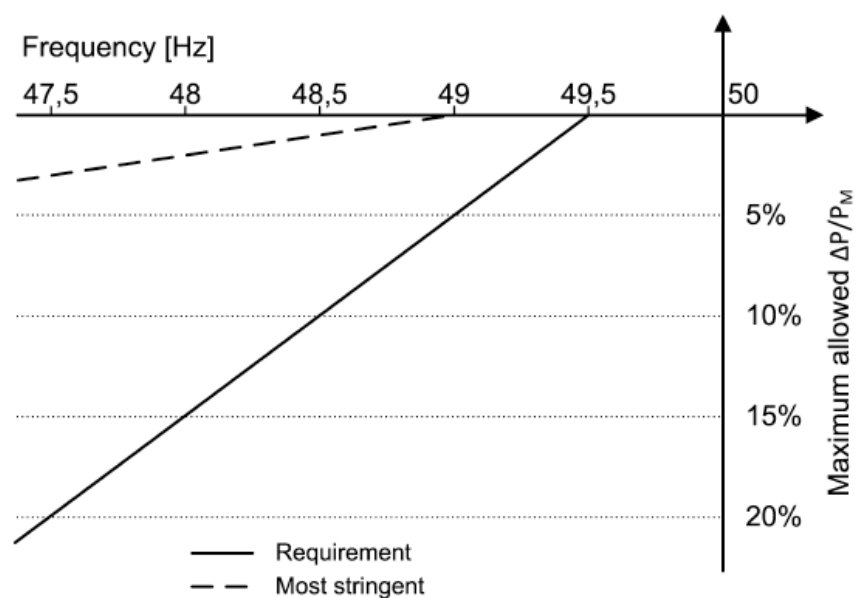
The frequency should then be set to 49,5 Hz for 5 minutes. The output should remain at 100% of registered Capacity.

The frequency should then be set to 49,0 Hz and once the output has stabilised, held at this frequency for 5 minutes. The Active Power output must not be below 99% of registered Capacity.

The frequency should then be set to 48,0 Hz and once the output has stabilised, held at this frequency for 5 minutes. The Active Power output must not be below 97% of registered Capacity.

The frequency should then be set to 47,6 Hz and once the output has stabilised, held at this frequency for 5 minutes. The Active Power output must not be below 96.2% of registered Capacity.

The frequency should then be set to 47,1 Hz and held at this frequency for 20s. The Active Power output must not be below 95,0% of registered Capacity and the Synchronous Power Generating Module must not trip in less than the 20s of the test.



Maximum allowable power reduction in case of under-frequency

**Note:**

The tests had been performed on the SOFAR 24KTLX-G3 is valid for the SOFAR 15KTLX-G3, SOFAR 17KTLX-G3, SOFAR 20KTLX-G3 and SOFAR 22KTLX-G3, since it is identical in hardware and software construction except output power derated by software.

**EN 50549-1:2019: Immunity to disturbances**

Clause	Test requirement	Test procedure according standard	Result
4.5.2	Rate of change of frequency (RoCoF) immunity	G99/1-4:2019, clause A.7.1.2.6	<b>P</b>
4.5.3	Low voltage ride through (LVRT)	VDE V 0124-100:2019-02 (Draft), clause 5.8.3.	<b>P</b>
4.5.4	High voltage ride through (HVRT)	VDE V 0124-100:2019-02 (Draft), clause 5.8.3.	<b>P</b>
4.7.4	Zero current mode for converter connected generating plants	VDE V 0124-100:2019-02 (Draft), clause 5.8.3.	<b>P</b>

4.5.2 Rate of change of frequency (ROCOF) immunity(default settings)				P
	Start Frequency	Change	End Frequency	Confirm no trip
Positive Frequency drift	49Hz	+2Hz/sec	51Hz	No trip
Negative Frequency drift	51Hz	-2Hz/sec	49Hz	No trip

**Note:**  
 Test method refer clause A.7.1.2.6 of G99/1-4:2019.  
 Hold for 10 s  
 Manufacturers considering new designs should allow for the RoCoF where stability is required to be increased to, up to 2Hz per second, as proposed in the new European network codes, which are expected to come into force over the period 2014/2015. Under these conditions RoCoF will cease to be an effective loss of mains protection and is unlikely to be permitted in future revisions of this document.  
 For the step change test the SSEG should be operated with a measureable output at the start frequency and then a vector shift should be applied by extending or reducing the time of a single cycle with subsequent cycles returning to the start frequency. The start frequency should then be maintained for a period of at least 10 seconds to complete the test. The SSEG should not trip during this test.  
 For frequency drift tests the SSEG should be operated with a measureable output at the start frequency and then the frequency changed in a ramp function at 0,95Hz per second to the end frequency. On reaching the end frequency it should be maintained for a period of at least10 seconds. The SSEG should not trip during this test.  
 The tests had been performed on the SOFAR 24KTLX-G3 is valid for the SOFAR 15KTLX-G3, SOFAR 17KTLX-G3, SOFAR 20KTLX-G3 and SOFAR 22KTLX-G3, since it is identical in hardware and software construction except output power derated by software.

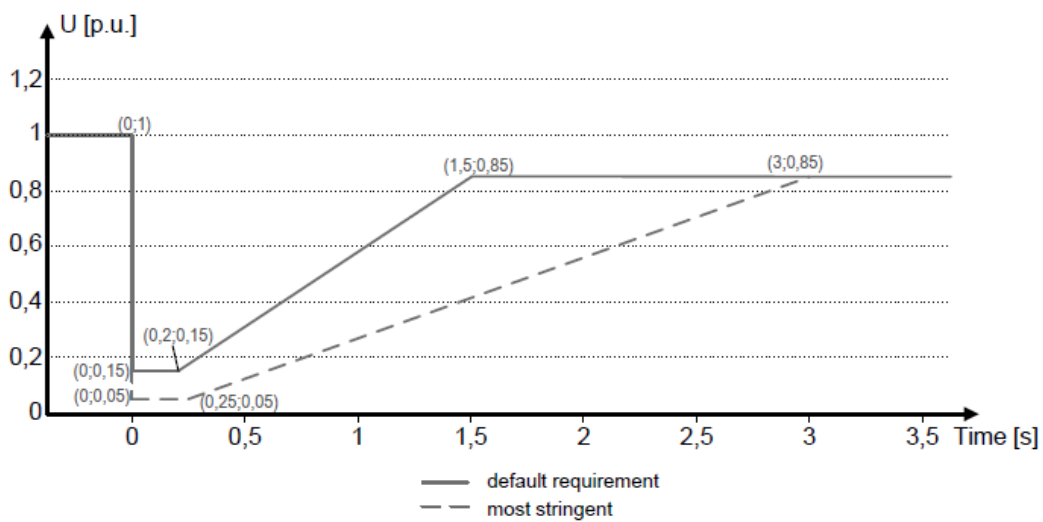
<p>4.5.3 4.5.4 4.7.4</p>	<p><b>Low voltage ride through (LVRT)</b> <b>High voltage ride through (HVRT)</b> <b>Zero current mode for converter connected generating plants</b></p>	<p><b>P</b></p>
----------------------------------	--	-----------------

**General:**

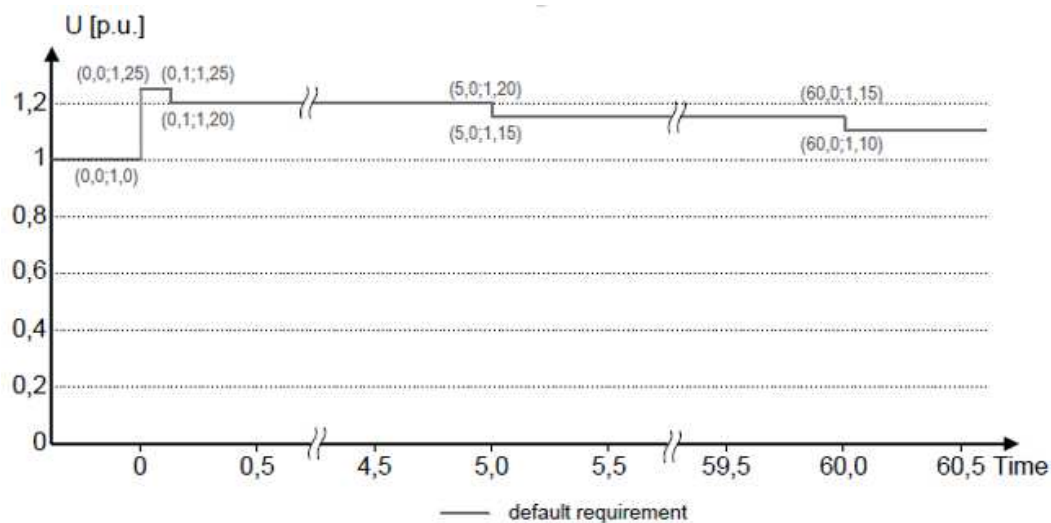
If the voltage on the generator terminals falls below  $<0.8 U_n$  and if the generator terminals exceed the voltage of  $> 1.15 U_n$  (start of fault), generator must pass through voltage dips without any current being drawn into the grid Network operator (limited dynamic network support).

This requirement is met if, for a voltage dip below  $0.8 U_n$  or at a voltage increase above  $1.15 U_n$ , the injected current of the generating unit (s) and / or the memory 60 ms after occurrence of this voltage dip in any outer conductor 20% of the rated current  $I_r$  and does not exceed  $> 10\% I_r$  after 100 ms.

After the voltage returned to continuous operating voltage range of  $-15\% U_n$  to  $+10\% U_n$ , 90 % of pre fault power or available power whichever is the smallest shall be resumed as fast as possible, but at the latest within 1 s unless the DSO and the responsible party requires another value.



**Figure 6 — Low voltage ride through capability for non-synchronous generating technology**



**Figure 8 — Over-voltage ride through capability**

Test	Drop depth requirement [p.u. $U_n$ ]	Symmetry	Fault duration [ms]	Output power level		k-factor	Test no.
				P set point ( $P_{RE}$ / p.u.)	Q set point (Q / p.u.)		
1.A.1	0,03	Symmetrical	250	1,0	0,00	0	1.A.1
1.A.2				0,2			1.A.2
1.D.1		Asymmetrical		1,0			1.D.1
1.D.2				0,2			1.D.2
1.B.1		Single phase*		1,0			1.B.1
1.B.2				0,2			1.B.2
2.A.1	0,31	Symmetrical	1300	1,0	0,00	0	2.A.1
2.A.2				0,2			2.A.2
2.D.1		Asymmetrical		1,0			2.D.1
2.D.2				0,2			2.D.2
2.B.1		Single phase*		1,0			2.B.1
2.B.2				0,2			2.B.2
3.A.1	0,82	Symmetrical	3000	1,0	0,00	0	3.A.1
3.A.2				0,2			3.A.2
3.D.1		Asymmetrical		1,0			3.D.1
3.D.2				0,2			3.D.2
3.B.1		Single phase*		1,0			3.B.1
3.B.2				0,2			3.B.2
OV1	1,25	Symmetrical	100	1,0	0,00	0	OV1
OV2	1,20		5000	1,0			OV2
OV3	1,15		60000	1,0			OV3

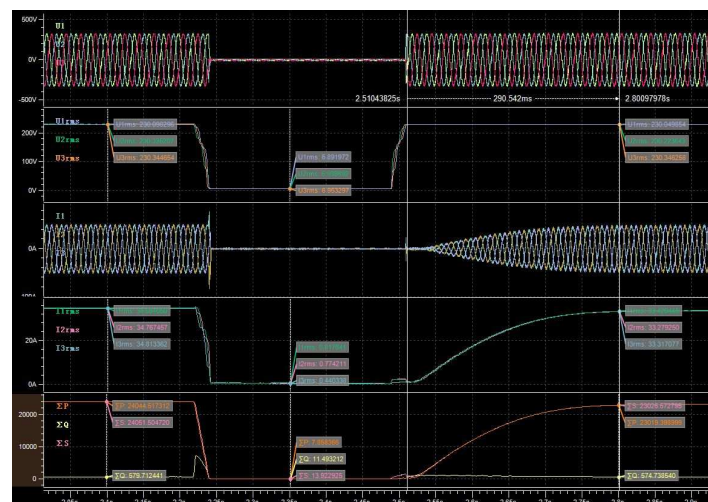
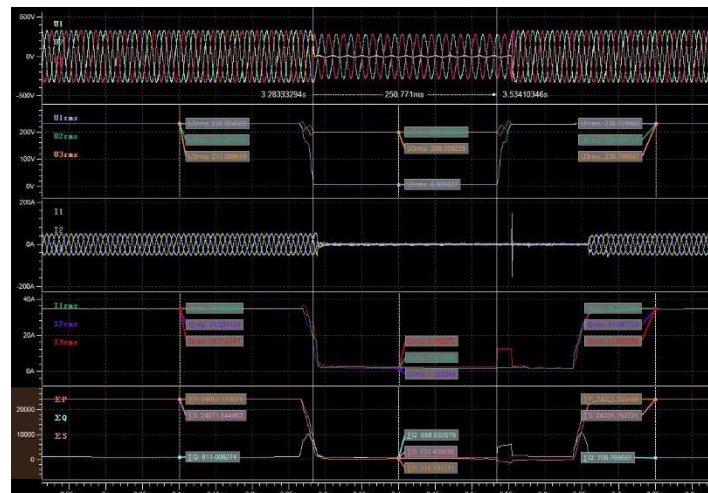
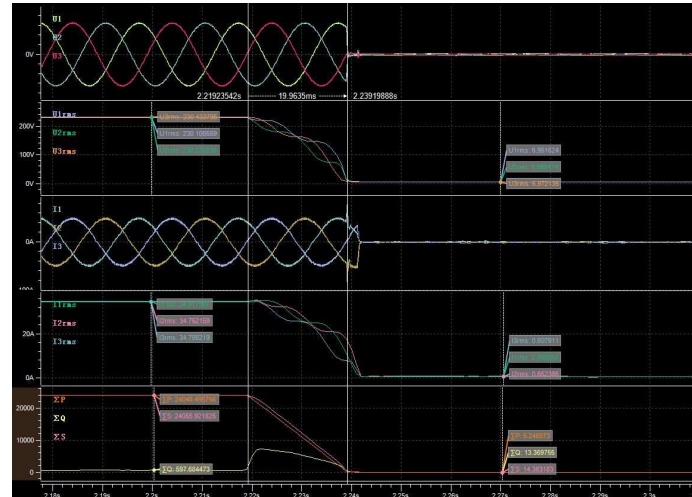
**Note:**

For every kind of voltage dip a test without load has to be performed in order to prove that the test condition was fulfilled. The voltage has to drop to AT LEAST the defined depth level. An exception can be considered in case no current is supplied during dips.

\* Single phase = "choose Typ 7 at BV-Lab Studio"  $\cong$  LVRT Typ B

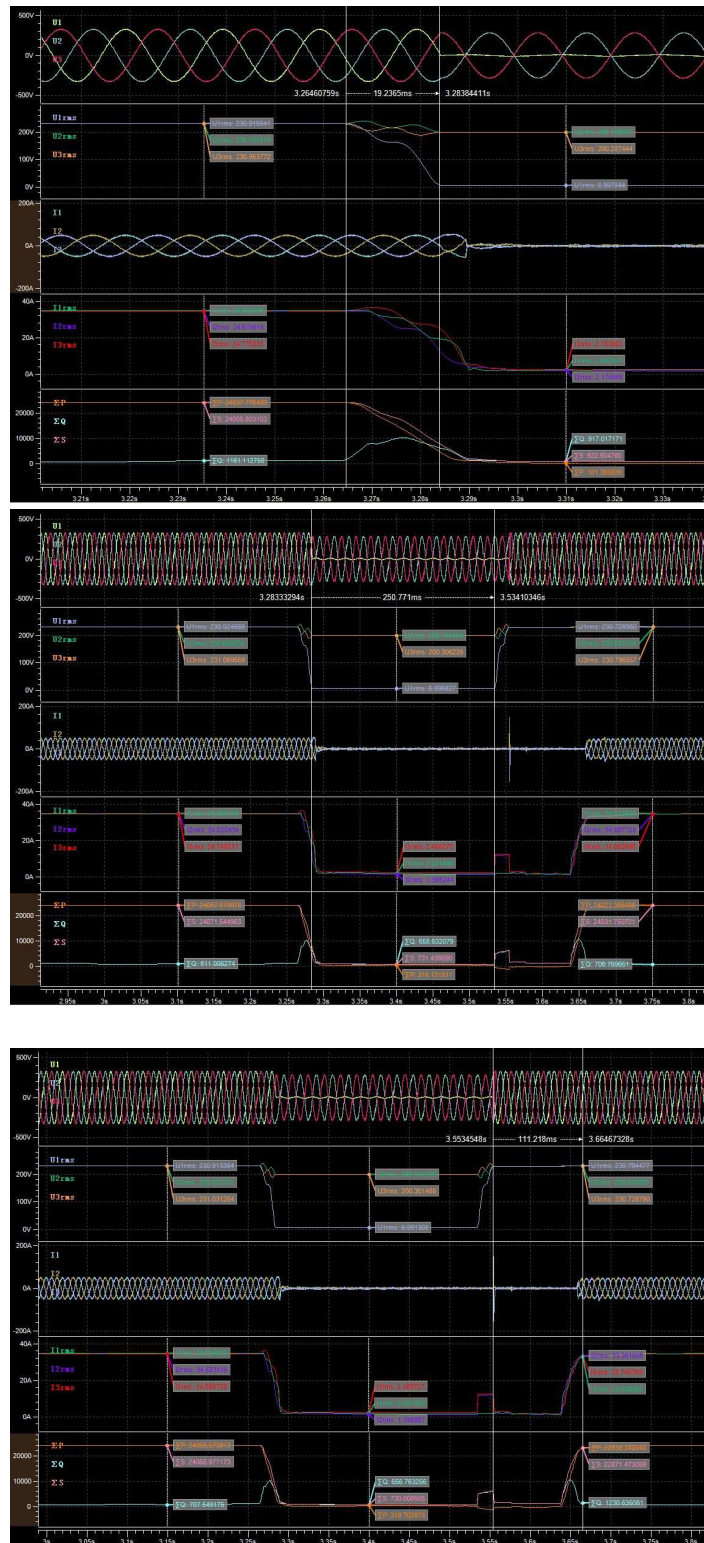
Graph of FRT test one				
Test result:				
List of tests	Residual amplitude of phase-to-phase voltage [p.u. $U_n$ ]	Duration limit [ms]	Duration [ms]	Result
$P_{E_{max}}$ in %	100% $\pm$ 5%			
1.A.1- Symmetrical	0,03	250 $\pm$ 20	251	Pass
1.D.1- Asymmetrical	0,03	250 $\pm$ 20	251	Pass
1.B.1- Single phase	0,03	250 $\pm$ 20	252	Pass
2.A.1- Symmetrical	0,31	1300 $\pm$ 20	1301	Pass
2.D.1- Asymmetrical	0,31	1300 $\pm$ 20	1301	Pass
2.B.1- Single phase	0,31	1300 $\pm$ 20	1300	Pass
3.A.1- Symmetrical	0,82	3000 $\pm$ 20	3001	Pass
3.D.1- Asymmetrical	0,82	3000 $\pm$ 20	3001	Pass
3.B.1- Single phase	0,82	3000 $\pm$ 20	3001	Pass
$P_{E_{max}}$ in %	20% $\pm$ 5%			
1.A.2- Symmetrical	0,03	250 $\pm$ 20	250	Pass
1.D.2- Asymmetrical	0,03	250 $\pm$ 20	250	Pass
1.B.2- Single phase	0,03	250 $\pm$ 20	251	Pass
2.A.2- Symmetrical	0,31	1300 $\pm$ 20	1301	Pass
2.D.2- Asymmetrical	0,31	1300 $\pm$ 20	1300	Pass
2.B.2- Single phase	0,31	1300 $\pm$ 20	1301	Pass
3.A.2- Symmetrical	0,82	3000 $\pm$ 20	3002	Pass
3.D.2- Asymmetrical	0,82	3000 $\pm$ 20	3000	Pass
3.B.2- Single phase	0,82	3000 $\pm$ 20	3000	Pass
$P_{E_{max}}$ in %	100% $\pm$ 5%			
OV1- Symmetrical	1,25	100 $\pm$ 20	100	Pass
OV2- Symmetrical	1,20	5000 $\pm$ 20	5001	Pass
OV3- Symmetrical	1,15	60000 $\pm$ 20	60000	Pass
<b>Test conditions:</b>				
Voltage simulator fall and rise time: < 20ms				
Used sample rate: 10 kHz				
<b>Note:</b>				
The test method refer to VDE V 0124-100:2019-02 (Draft), clause 5.8.3.				
The tests had been performed on the SOFAR 24KTLX-G3 is valid for the SOFAR 15KTLX-G3, SOFAR 17KTLX-G3, SOFAR 20KTLX-G3 and SOFAR 22KTLX-G3, since it is identical in hardware and software construction except output power derated by software.				

Test 1.A.1-Symmetrical fault ( $U/U_{nom} = 0,03$ );  $P = 100\% \pm 5\% P_n$

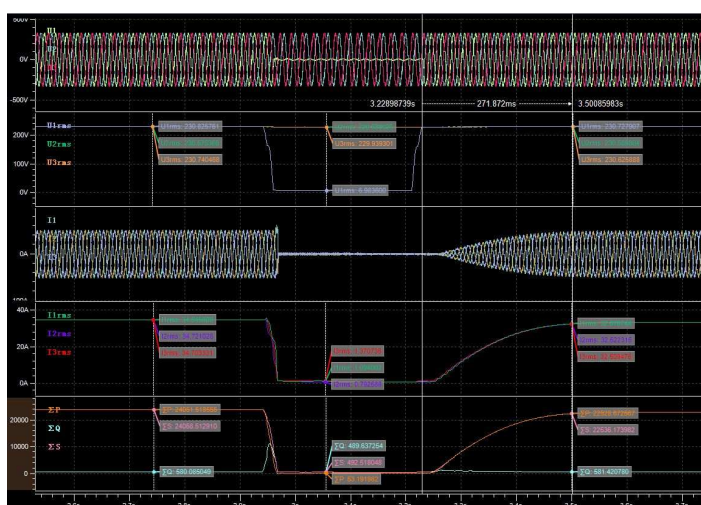
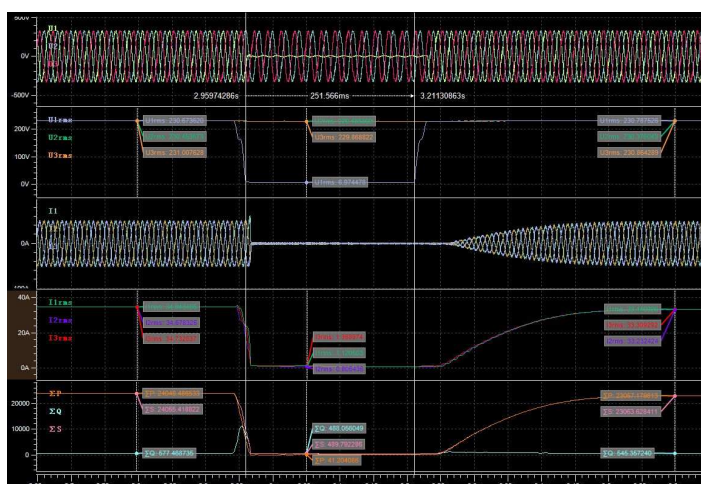
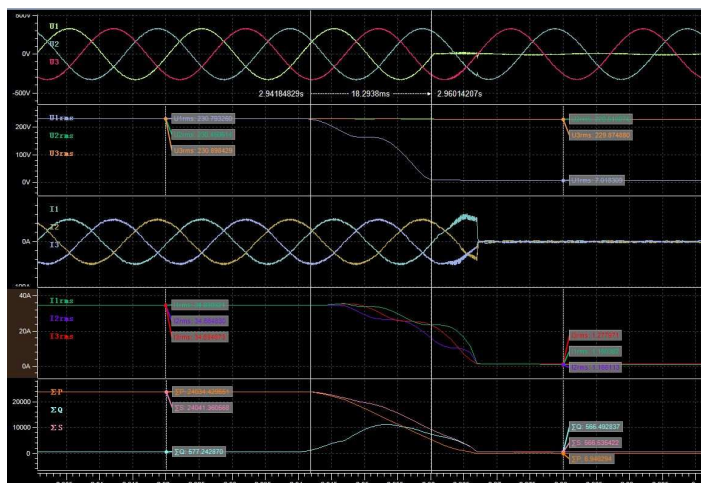




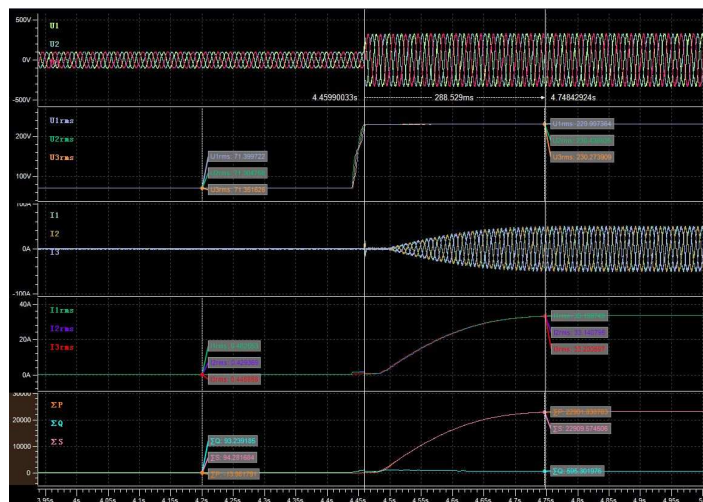
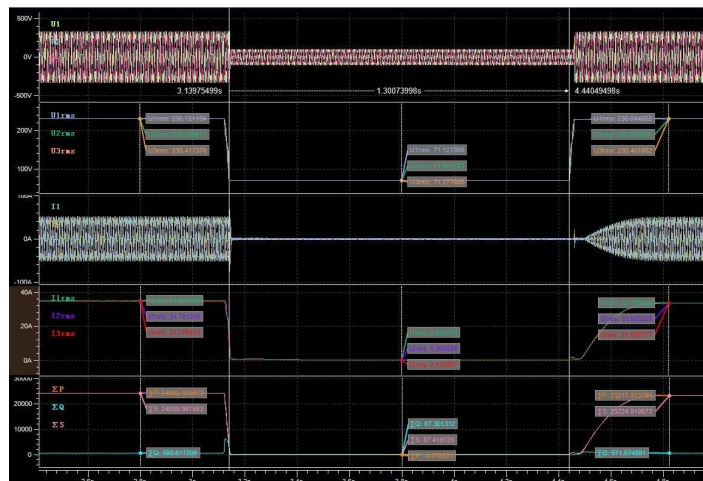
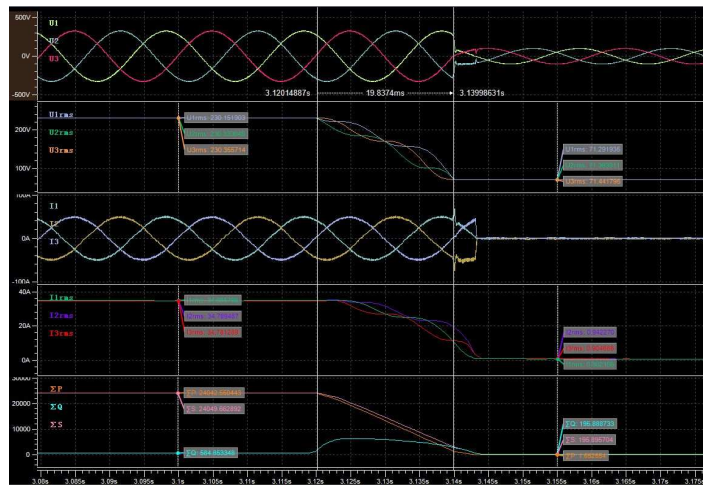
Test 1.D.1-Asymmetrical fault (U/U<sub>nom</sub> = 0,03); P = 100% ±5% P<sub>n</sub>



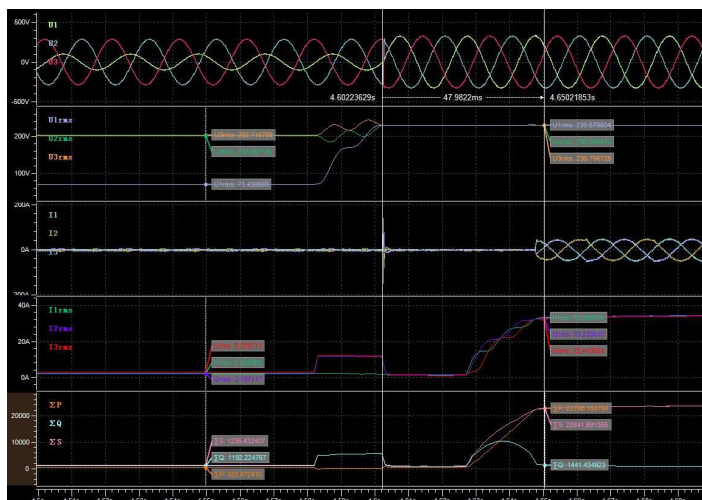
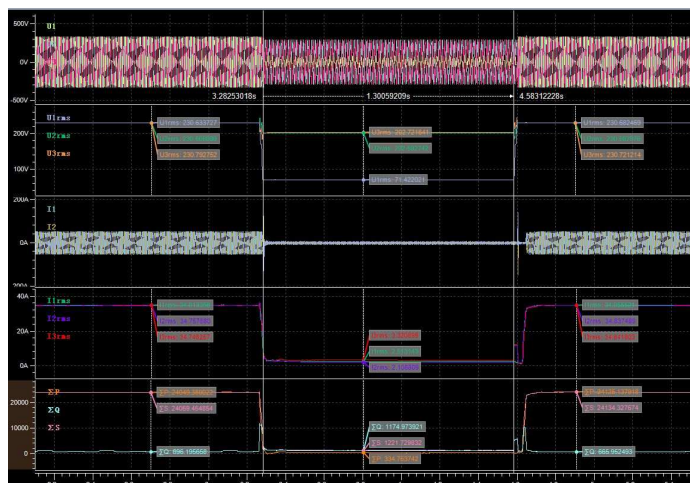
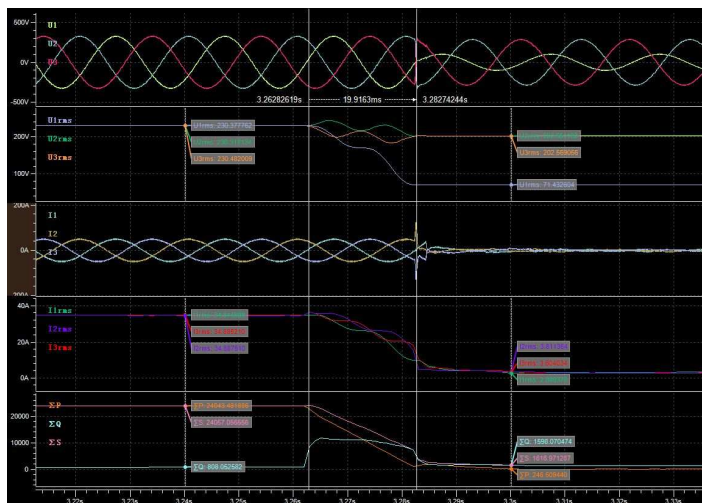
Test 1.B.1-Single phase fault ( $U/U_{nom} = 0,03$ );  $P = 100\% \pm 5\% P_n$



Test 2.A.1-Symmetrical fault ( $U/U_{nom} = 0,31$ );  $P = 100\% \pm 5\% P_n$



Test 2.D.1- Asymmetrical fault (U/U<sub>nom</sub> = 0,31); P = 100% ±5% P<sub>n</sub>

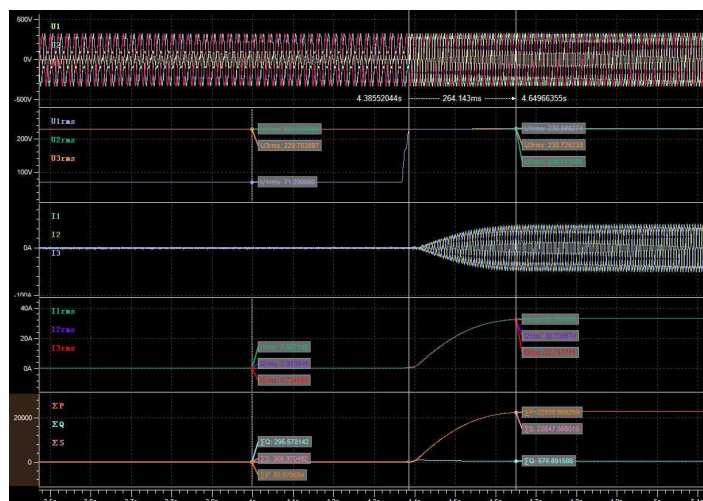
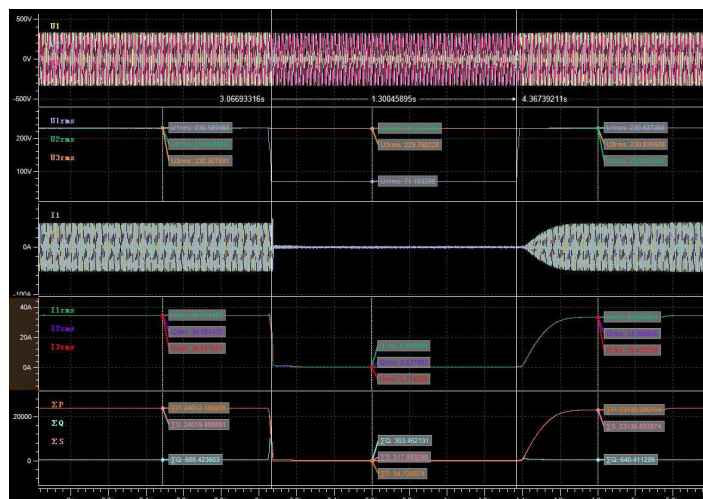
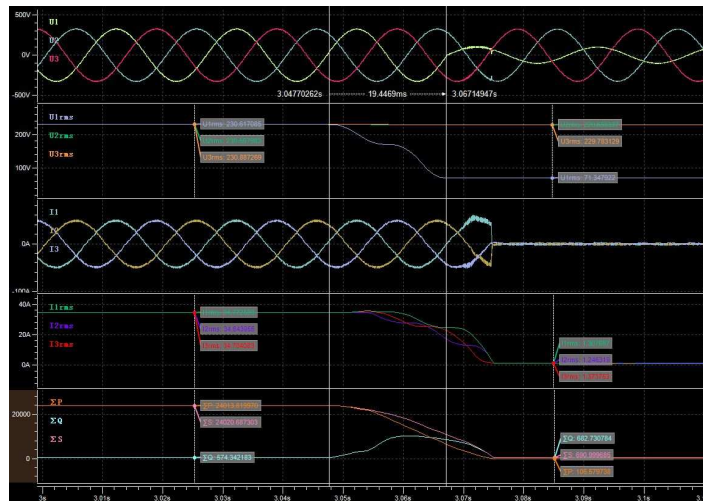




BUREAU VERITAS

Report No.: PVIR200511N080-2

### Test 2.B.1-Single phase fault ( $U/U_{nom} = 0,31$ ); $P = 100\% \pm 5\% P_n$

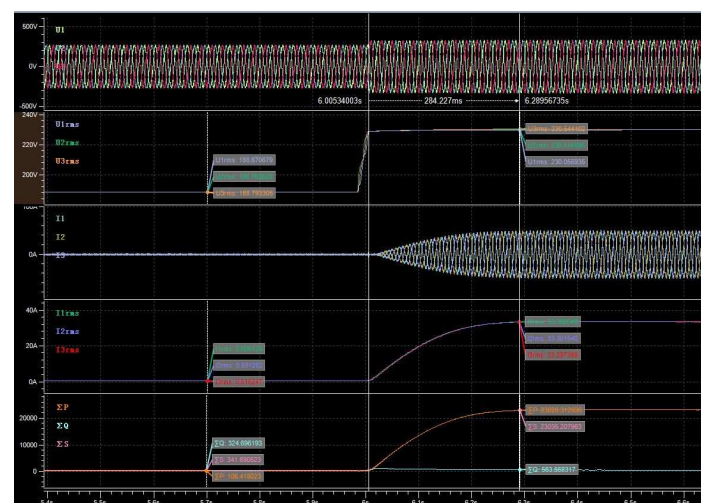
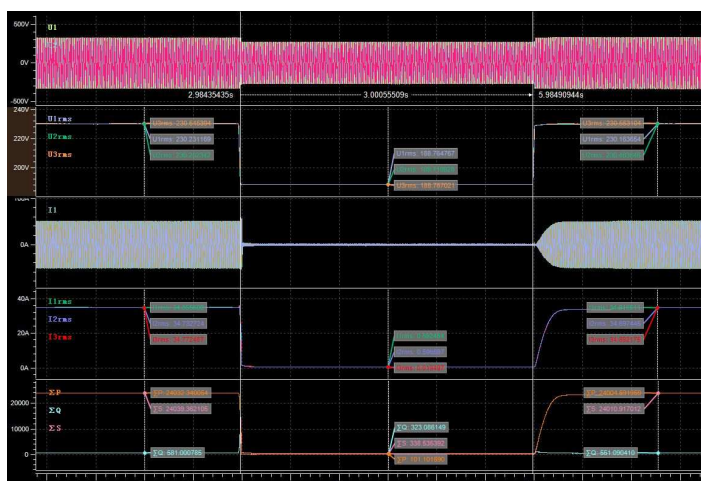
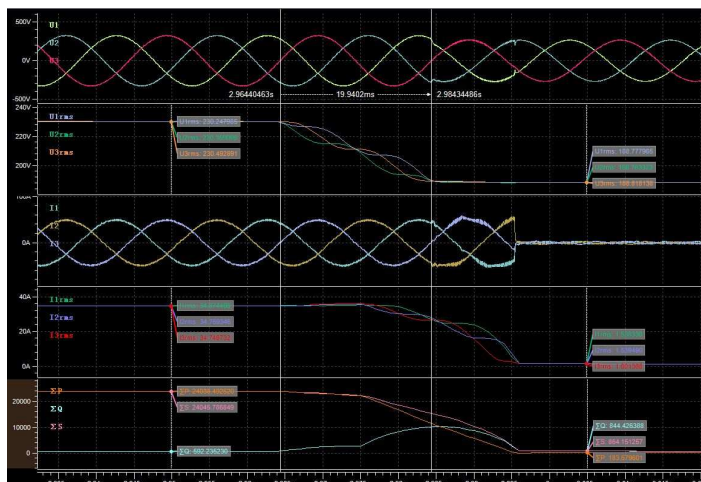




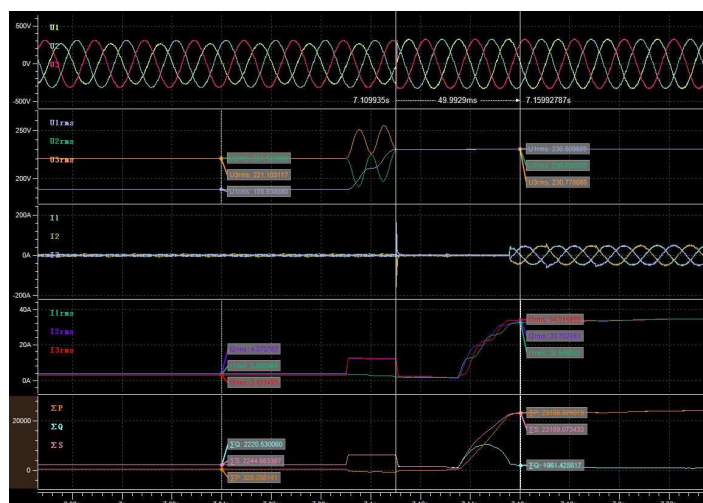
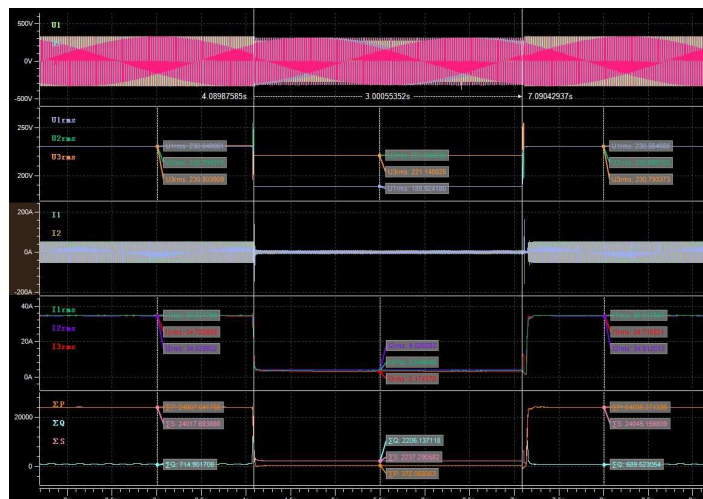
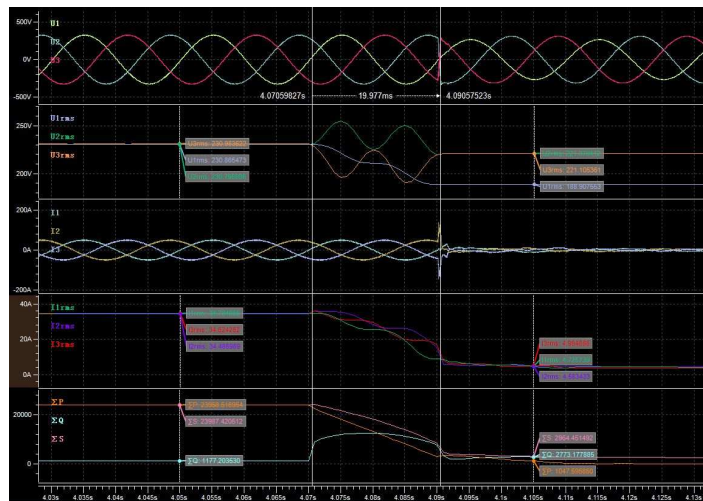
BUREAU  
VERITAS

Report No.: PVIR200511N080-2

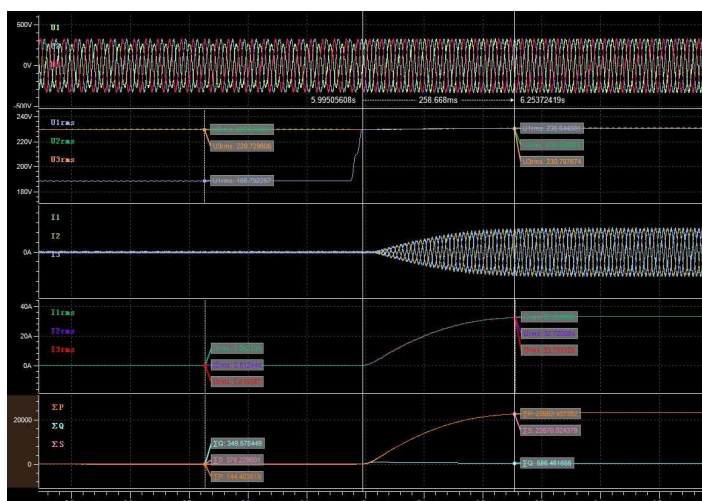
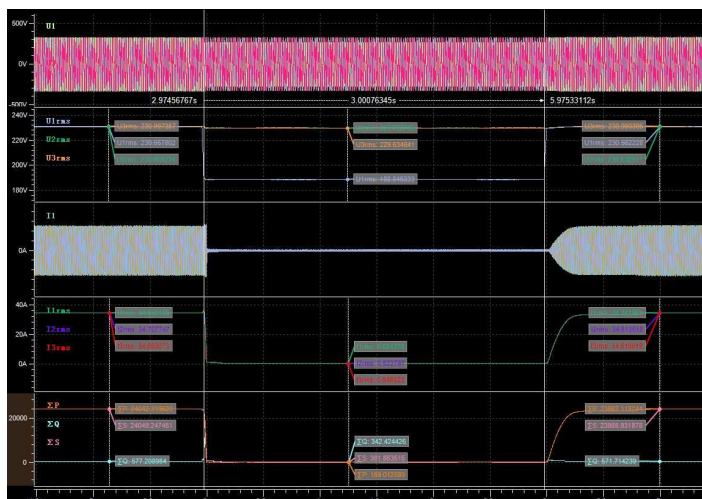
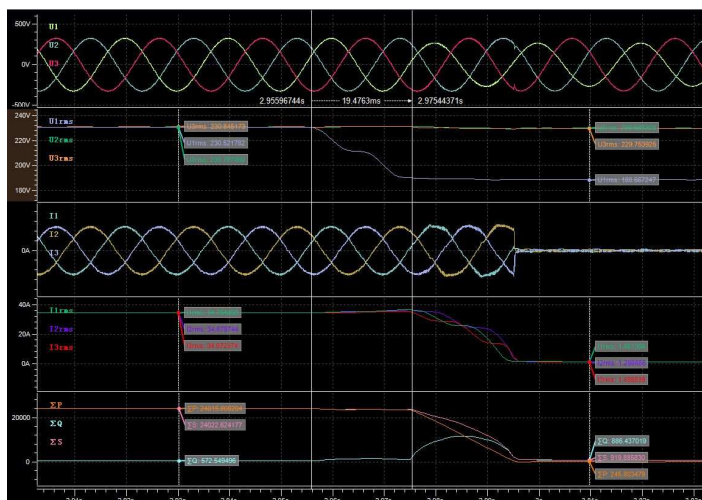
### Test 3.A.1-Symmetrical fault ( $U/U_{nom} = 0,82$ ); $P = 100\% \pm 5\% P_n$



Test 3.D.1-Asymmetrical fault (U/U<sub>nom</sub> = 0,82); P = 100% ±5% P<sub>n</sub>

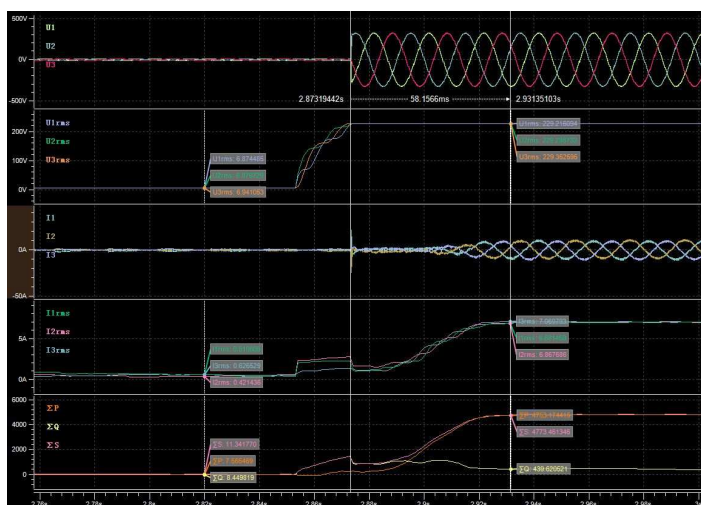
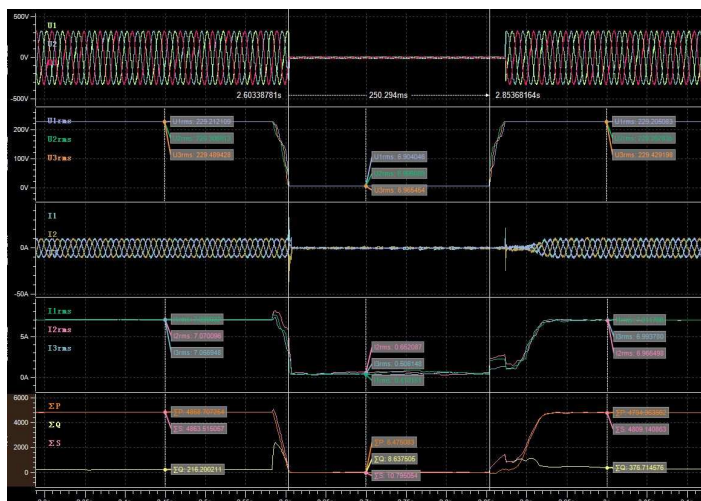
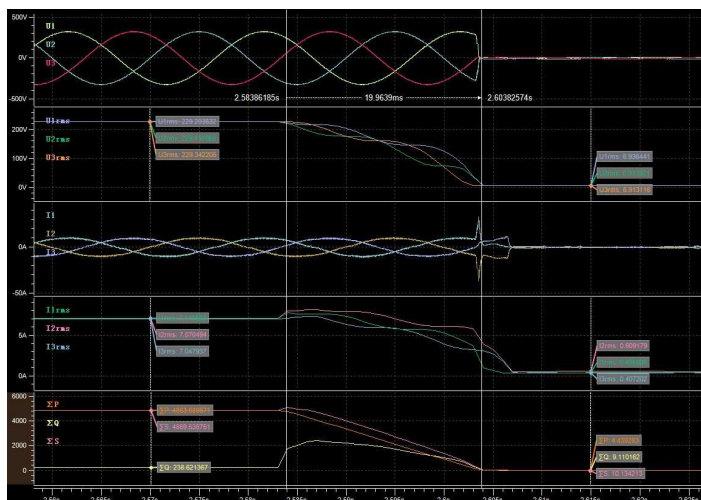


Test 3.B.1-Single phase fault ( $U/U_{nom} = 0,82$ );  $P = 100\% \pm 5\% P_n$

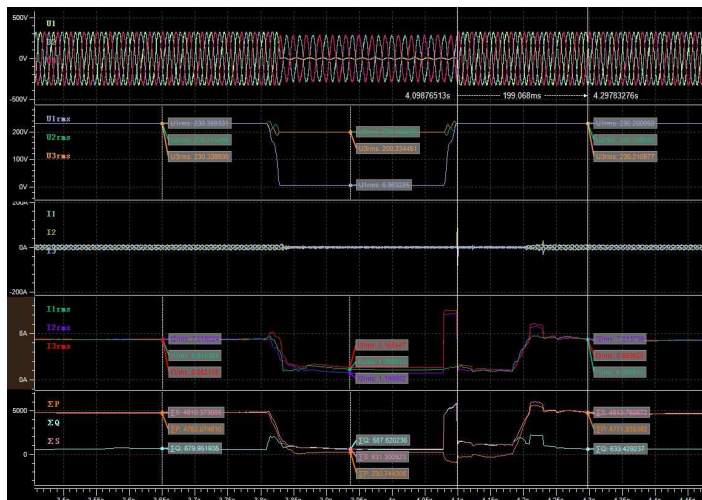
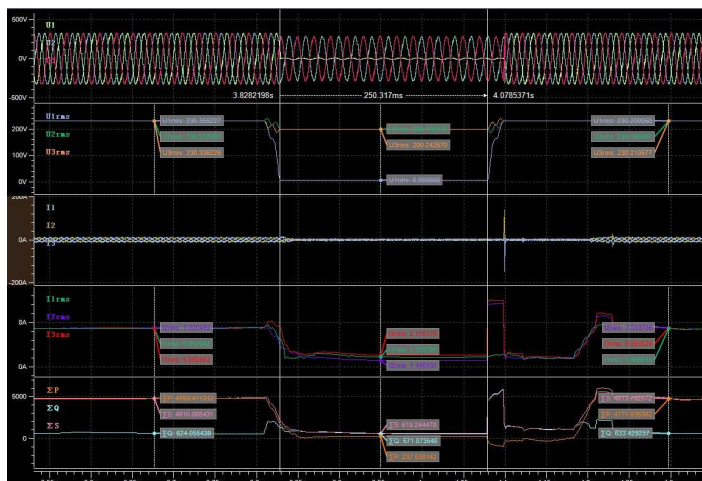
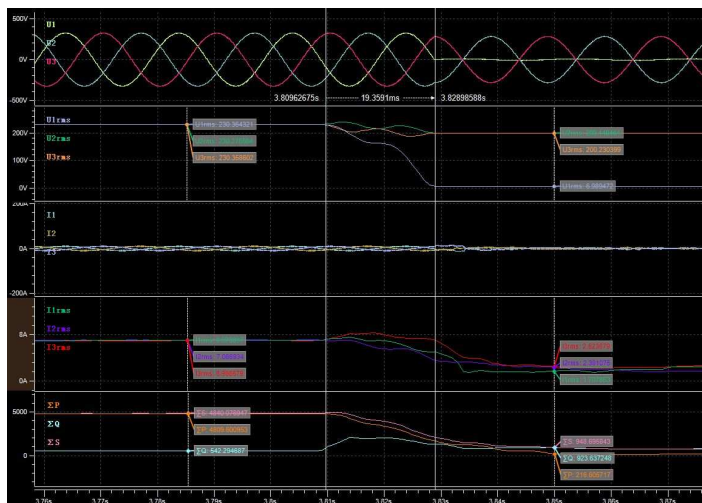




Test 1.A.2-Symmetrical fault (U/U<sub>nom</sub> = 0,03); P = 20% ±5% P<sub>n</sub>

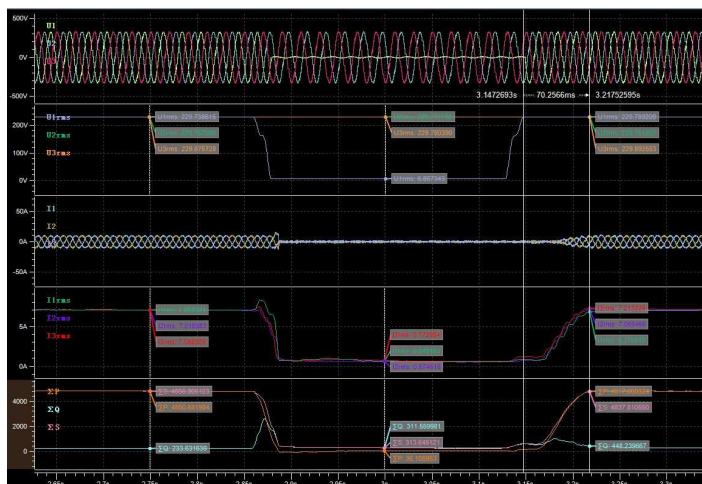
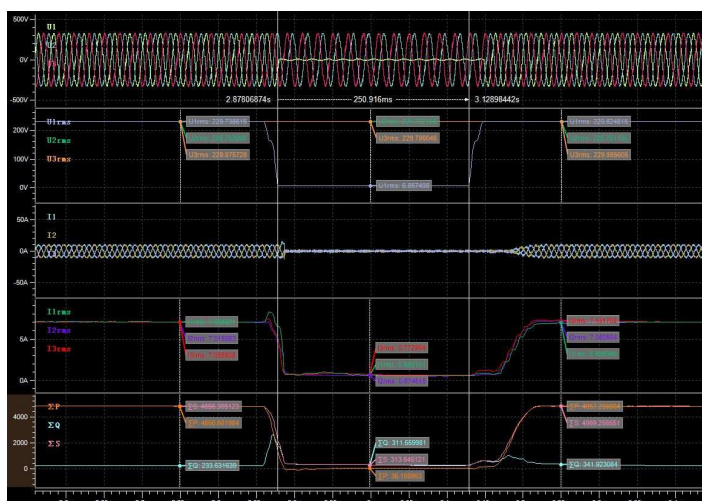
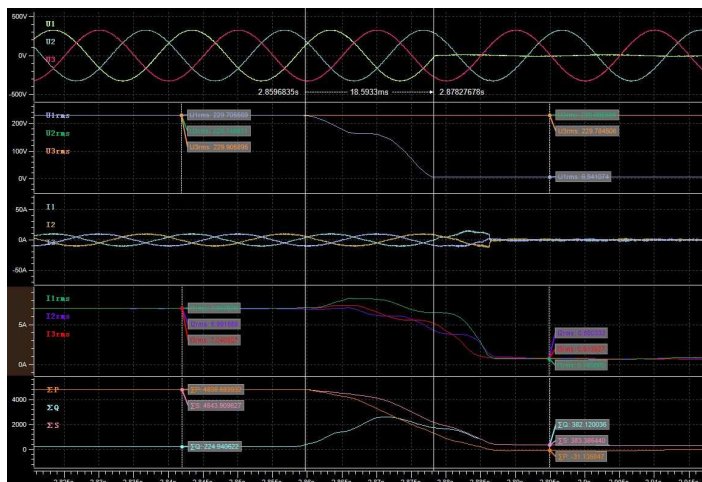


Test 1.D.2-Asymmetrical fault (U/U<sub>nom</sub> = 0,03); P = 20% ±5% P<sub>n</sub>

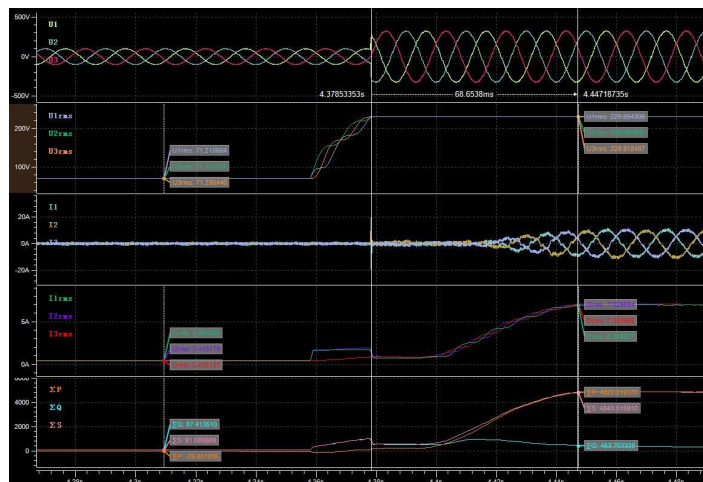
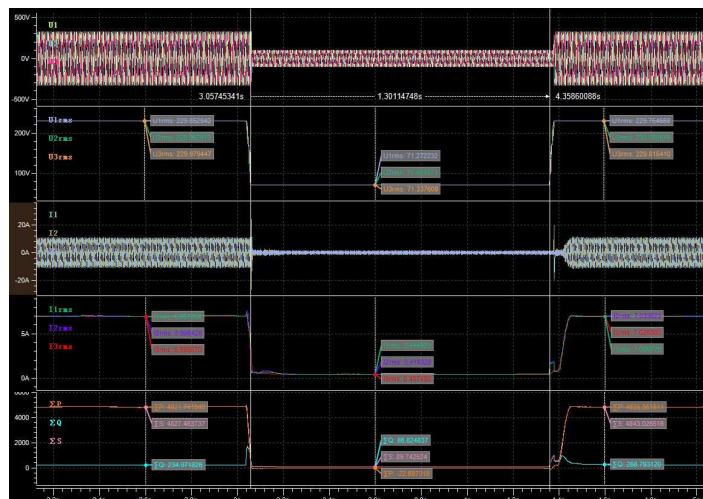
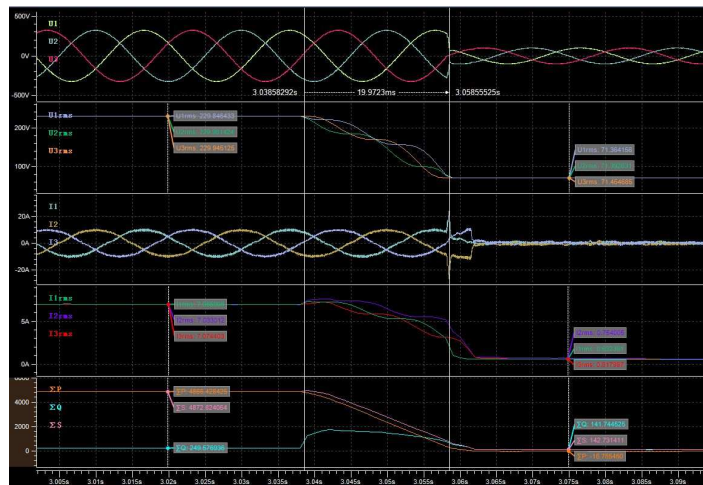




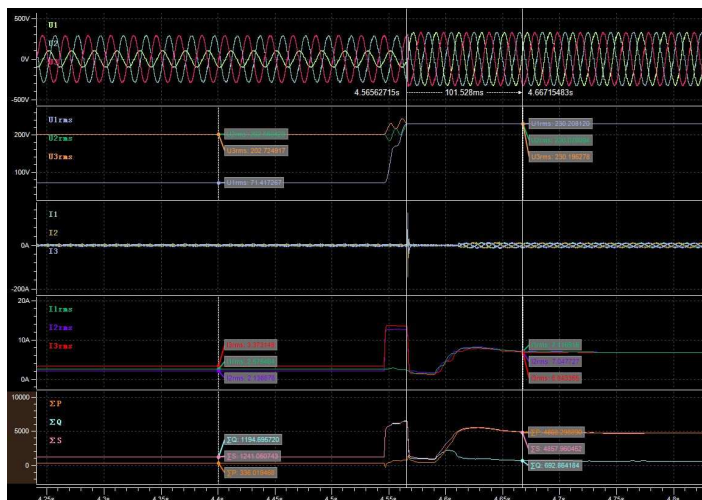
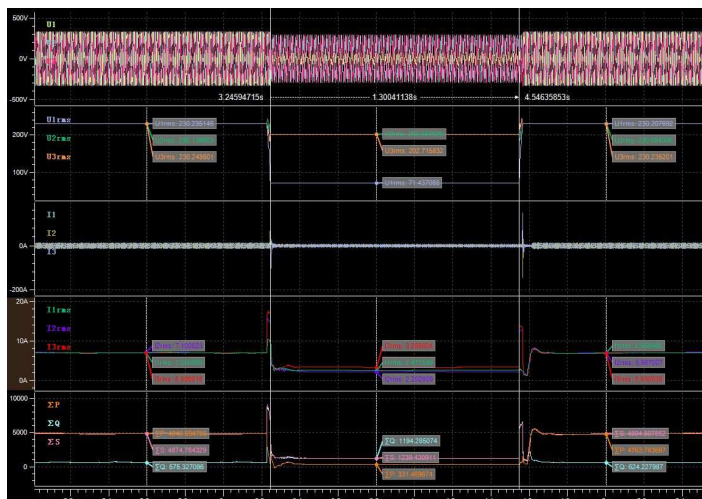
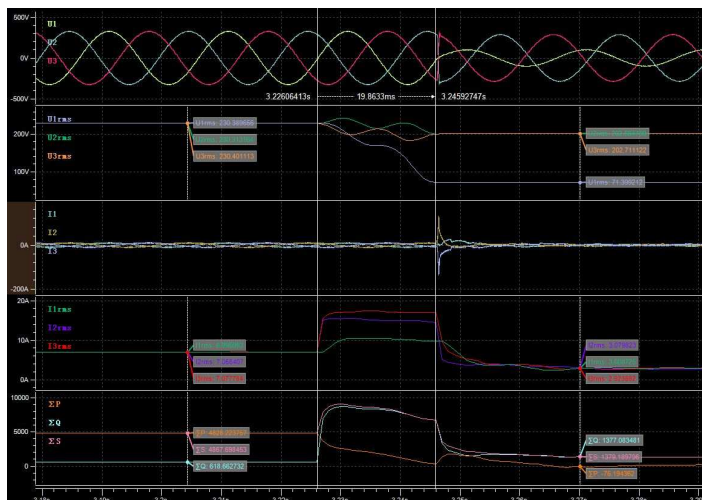
Test 1.B.2-Single phase fault (U/U<sub>nom</sub> = 0,03); P = 20% ±5% P<sub>n</sub>



Test 2.A.2-Symmetrical fault ( $U/U_{nom} = 0,31$ );  $P = 20\% \pm 5\% P_n$



Test 2.D.2-Asymmetrical fault (U/U<sub>nom</sub> = 0,31); P = 20% ±5% P<sub>n</sub>

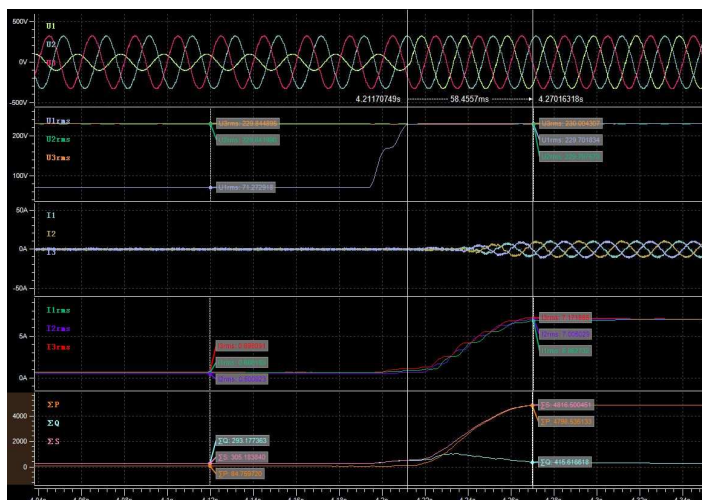
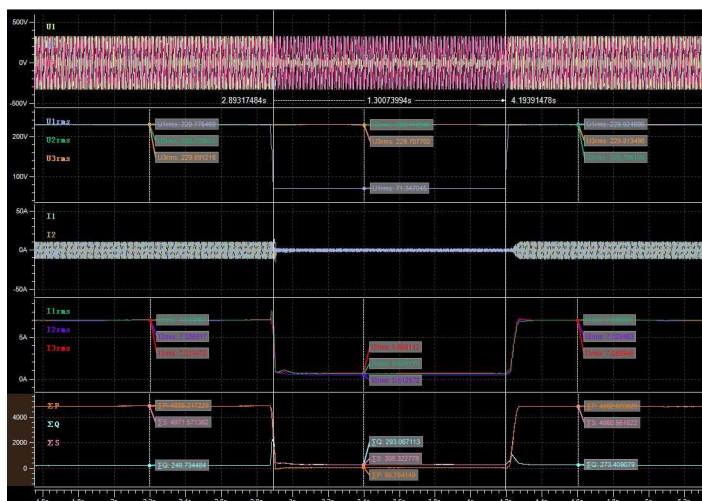
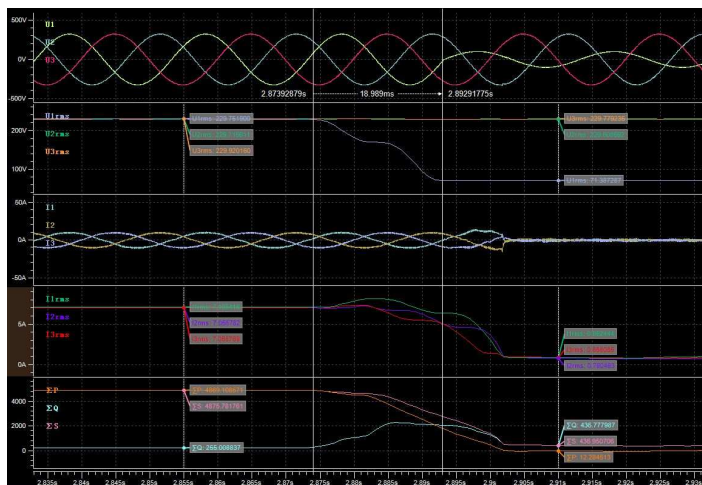




BUREAU VERITAS

Report No.: PVIR200511N080-2

Test 2.B.2-Single phase fault (U/U<sub>nom</sub> = 0,31); P = 20% ±5% P<sub>n</sub>

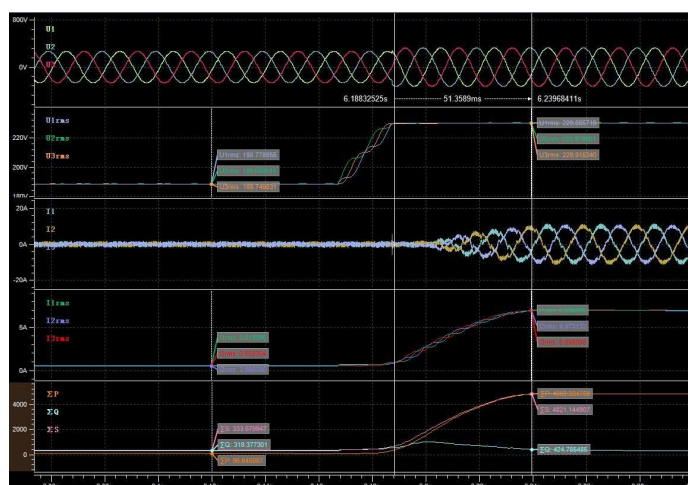
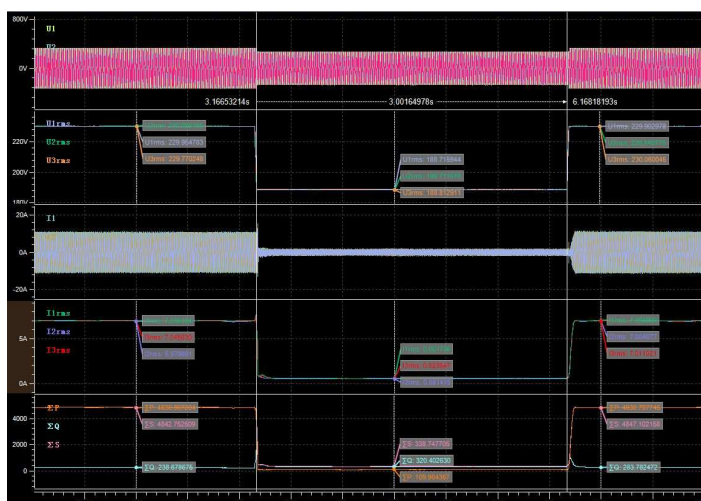
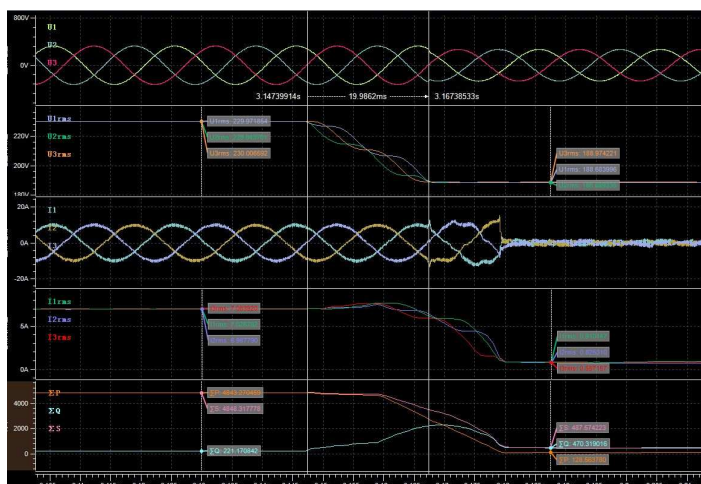




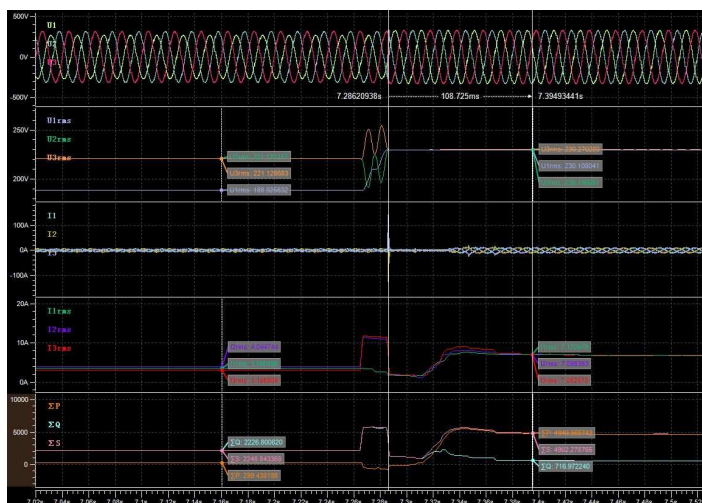
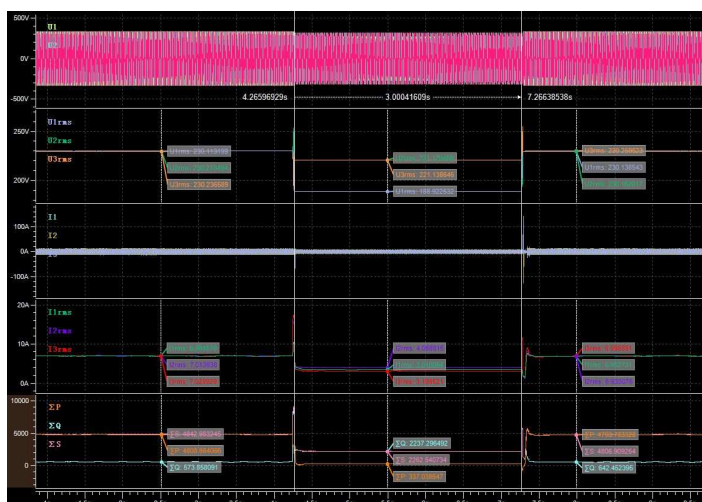
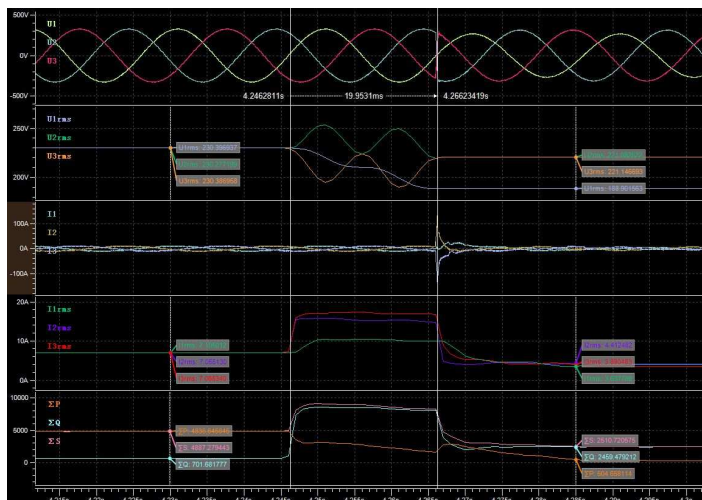
BUREAU  
VERITAS

Report No.: PVIR200511N080-2

### Test 3.A.2-Symmetrical fault ( $U/U_{nom} = 0,82$ ); $P = 20\% \pm 5\% P_n$

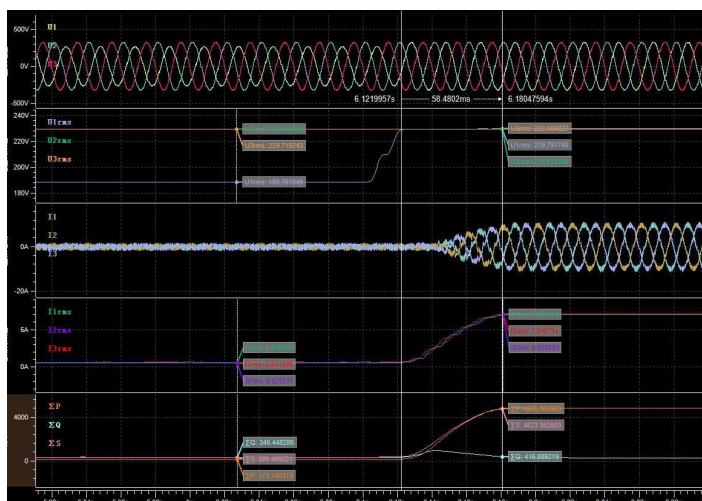
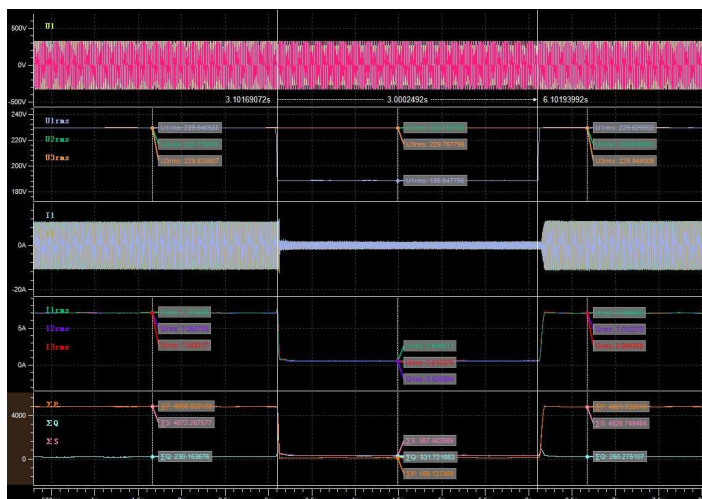
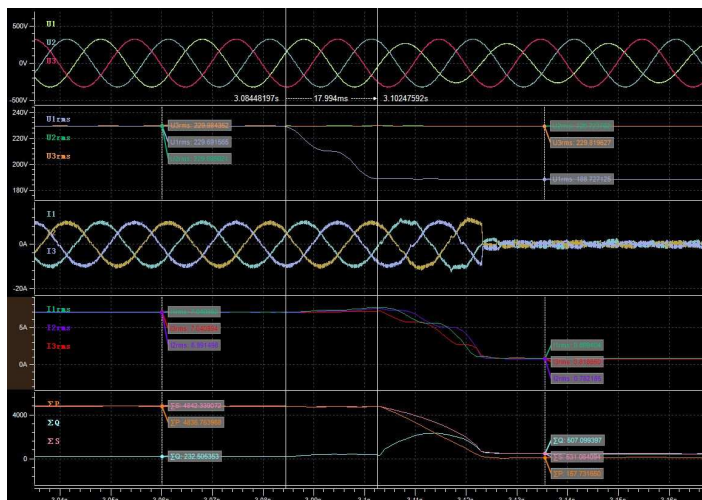


Test 3.D.2-Asymmetrical fault ( $U/U_{nom} = 0,82$ );  $P = 20\% \pm 5\% P_n$

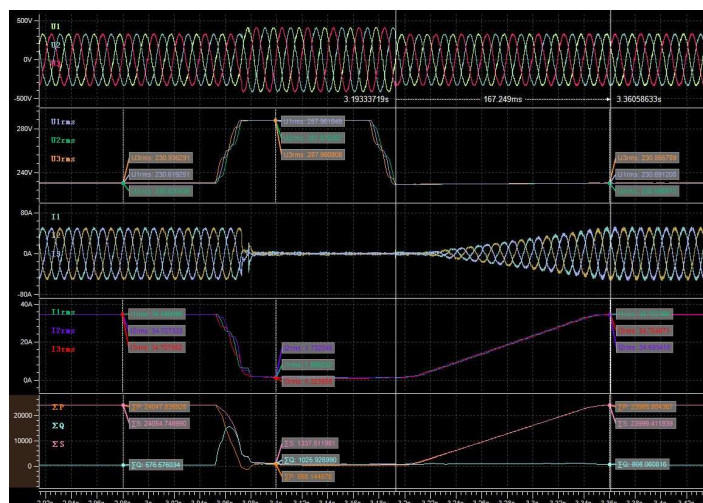
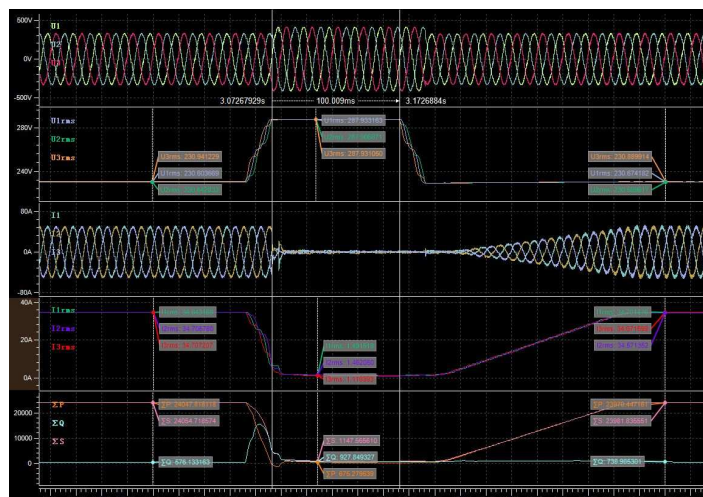
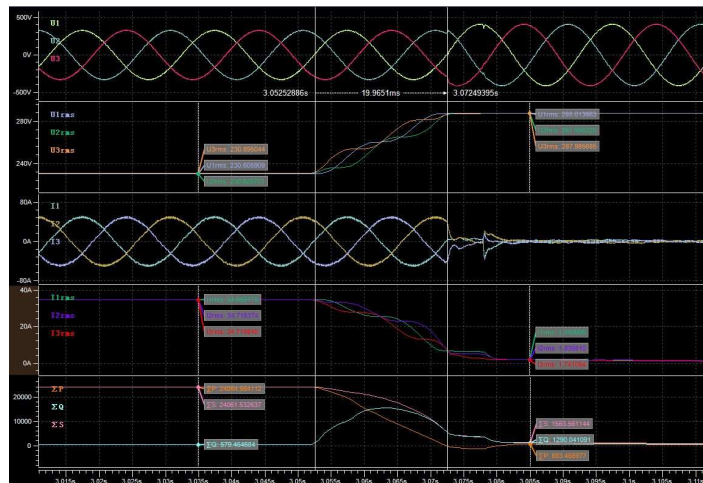




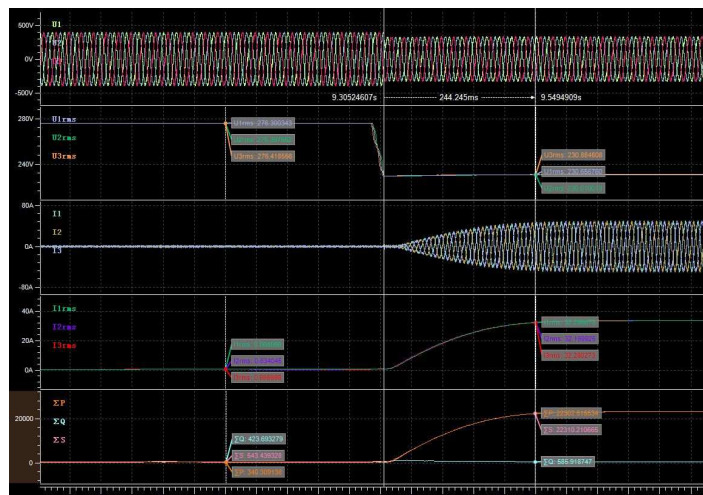
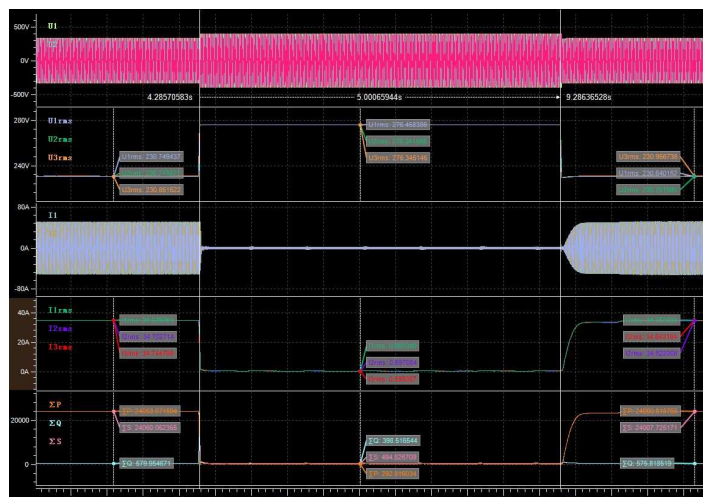
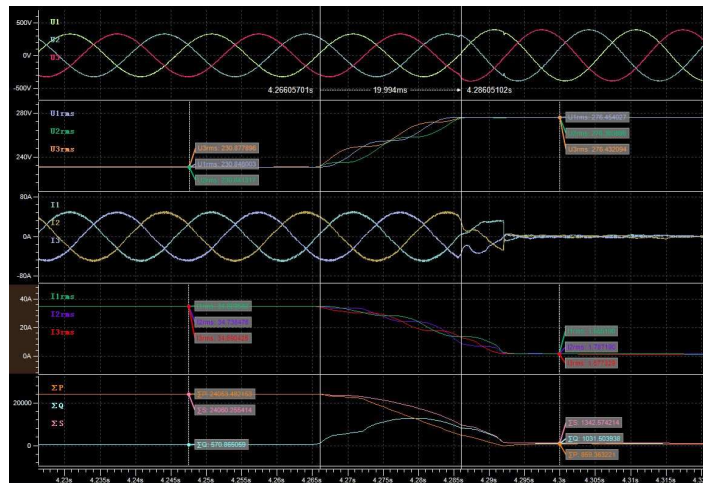
Test 3.B.2-Single phase fault (U/U<sub>nom</sub> = 0,82); P = 20% ±5% P<sub>n</sub>



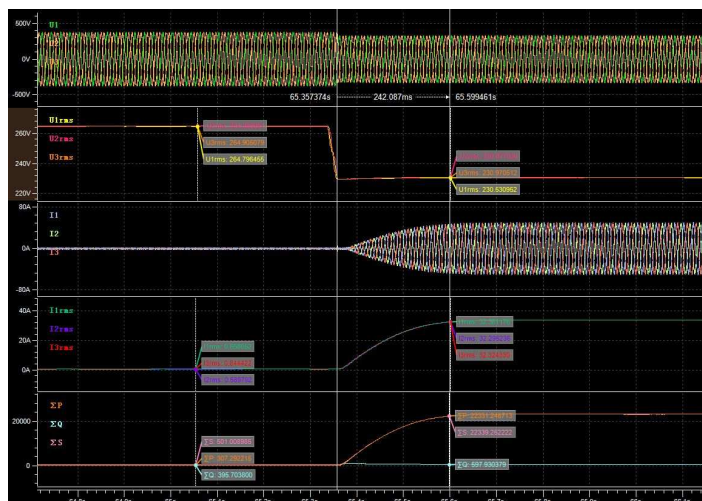
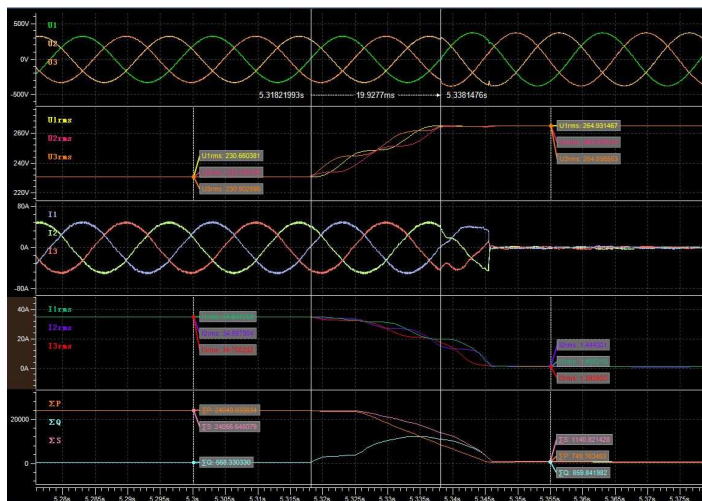
Test OV1-Symmetrical fault (U/U<sub>nom</sub> = 1,25); P = 100% ±5% P<sub>n</sub>



Test OV2-Symmetrical fault (U/U<sub>nom</sub> = 1,20); P = 100% ±5% P<sub>n</sub>



Test OV3-Symmetrical fault (U/U<sub>nom</sub> = 1,15); P = 100% ±5% P<sub>n</sub>



### EN 50549-1:2019: Active response to frequency deviation

Clause	Test requirement	Test procedure according standard	Result
4.6.1	Power response to over-frequency	VDE V 0124-100:2019-02 (Draft), clause 5.4.4	P
4.6.2	Power response to under-frequency	VDE V 0124-100:2019-02 (Draft), clause 5.4.6	P

<b>4.6.1 Power response to over-frequency</b>	<b>P</b>
---	----------

**Test result:**

1-min mean value [Hz]:	a) 50,00	b) 50,25	c) 50,70	d) 51,40	e) 50,70	f) 50,25	g) 50,00
------------------------	----------	----------	----------	----------	----------	----------	----------

1. Measurement a) to g): Active power output =100%  $P_{E_{max}}$   
 $s=5\%$  (40%  $P_{ref}$  / Hz), threshold frequency for start/return: 50,2Hz

Frequency [Hz]:	50,00	50,25	50,70	51,40	50,70	50,25	50,00
$P_M$ [kW]:	N/A	23,521	19,202	12,482	19,202	23,522	N/A
$P_{E60}$ [kW]:	24,138	23,637	19,237	12,378	19,236	23,636	24,145
$\Delta P_{E60}/P_M$ [%]:	N/A	0,483	0,145	-0,431	0,144	0,477	N/A

**Test result:**

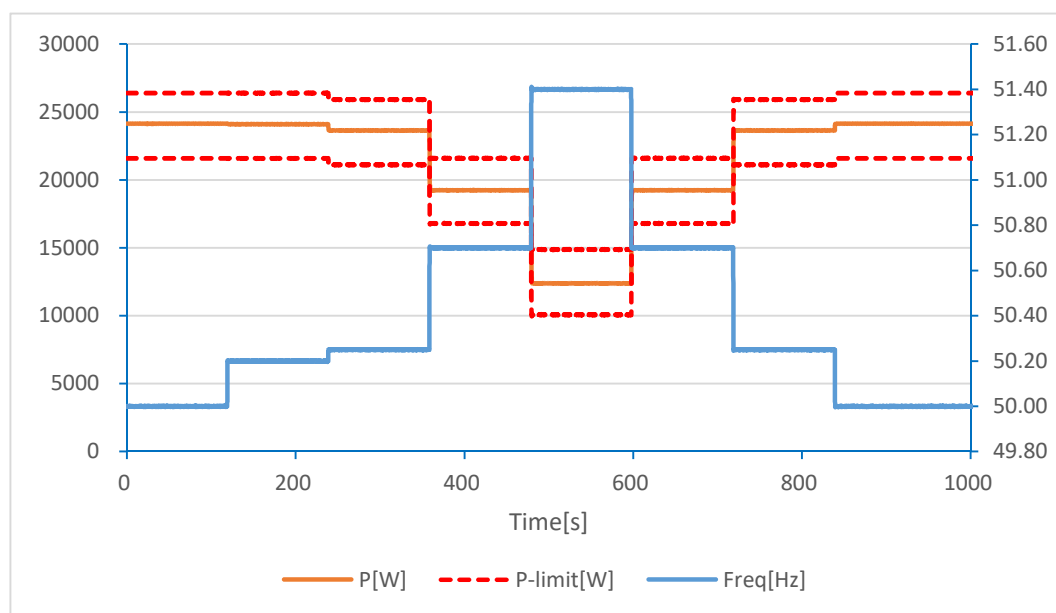
1-min mean value [Hz]:	a) 50,00	b) 50,25	c) 50,70	d) 51,40	e) 50,70	f) 50,25	g) 50,00
------------------------	----------	----------	----------	----------	----------	----------	----------

2. Measurement a) to g): Active power output 60% after freezing = 100%  $P_{E_{max}}$   
 $s=5\%$  (40%  $P_{ref}$  / Hz), threshold frequency for start/return: 50,2Hz

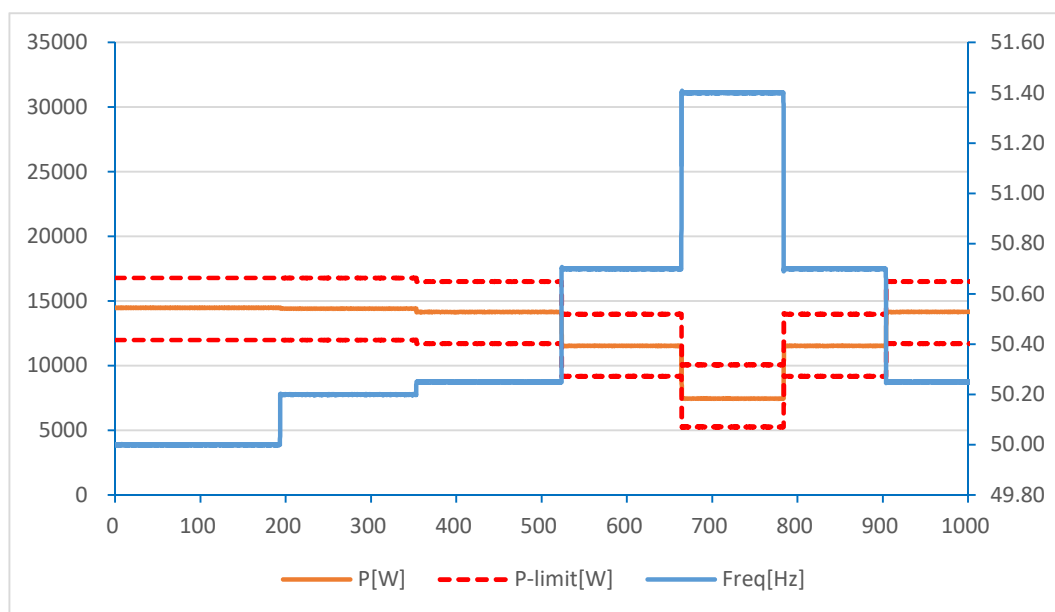
Frequency [Hz]:	50,00	50,25	50,70	51,40	50,70	50,25	50,00
$P_M$ [kW]:	N/A	14,113	11,521	7,489	11,521	14,113	N/A
$P_{E60}$ [kW]:	14,477	14,157	11,536	7,468	11,534	14,160	24,088
$\Delta P_{E60}/P_M$ [%]:	N/A	-0,18	-0,06	0,09	-0,05	-0,20	N/A

**Limit  $\Delta P/P_{1min}$ :**  $\pm 10\%$  of  $P_{E_{max}}$

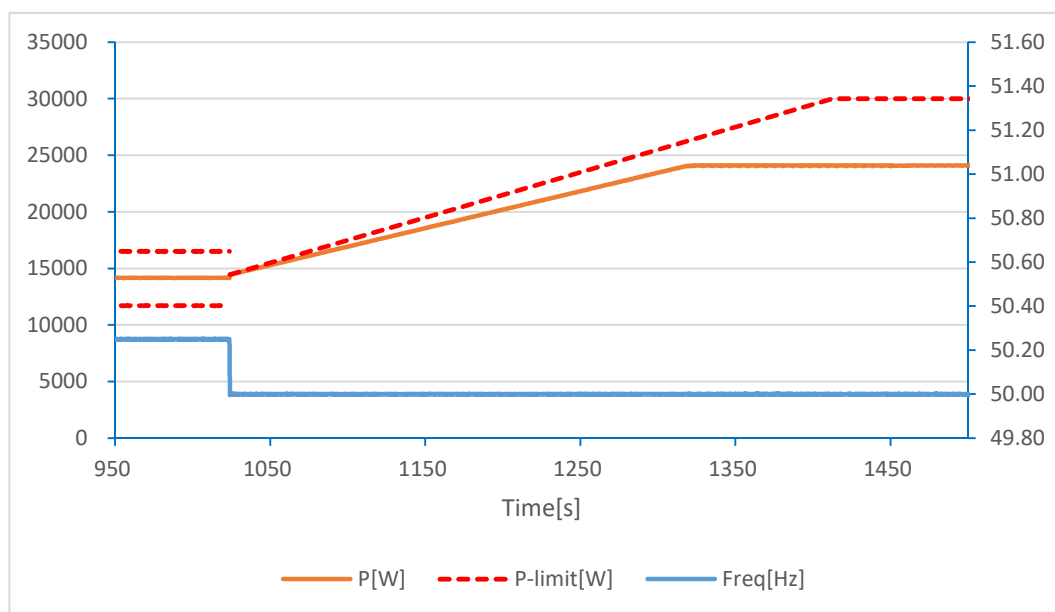
**Graph of Measurement 1.: Active power output > 80%  $P_{E_{max}}$**



**Graph of Measurement 2.:Active power output 40% and 60% after freezing > 80% P<sub>E</sub>max**



**Graph of power gradient:**



**Test:**

The test is conducted for two powers. First, the test must start at a power =100%  $P_{E_{max}}$  ("Measurement 1"), and in a second test, for a power 60%  $P_{E_{max}}$  ("Measurement 2"). In the second test, after freezing of the  $P_M$ , the available active power output must be increased to a value =100%  $P_{E_{max}}$ , and after the network frequency of 50,2 Hz is fallen below, the rise of the active power gradient must be recorded.

Point g) must be held until the micro-generator is again feeding in with the active power output available.

**Assessment criterion:**

For  $f = 50,2$  Hz, the value of the  $P_M$  active power currently being generated is "frozen".

a) For adjustable micro-generators when:

- 1) the active power reduces between measuring points b) and f) given above with the set gradient  $P_M$  per Hz for a increasing frequency (or rises for a frequency decreasing again).
- 2) the maximum active power gradient occurring in point is less than the configured maximum active power per minute
- 3) the reaction value of the setpoint determined by the gradient characteristic curve does not differ from  $P_{E_{max}}$  by more than  $\pm 10\%$ .
- 4) the settling time is equal or below 2 s with an intentional delay set to zero

b) For partly adjustable micro-generators

- 1) when they behave as in a) within their adjustment range, and
- 2) when, outside the adjustable range, the power fed in on leaving the adjustment range remains constant until shutdown. Shutdown must be no later than at 51,5 Hz.

**Note:**

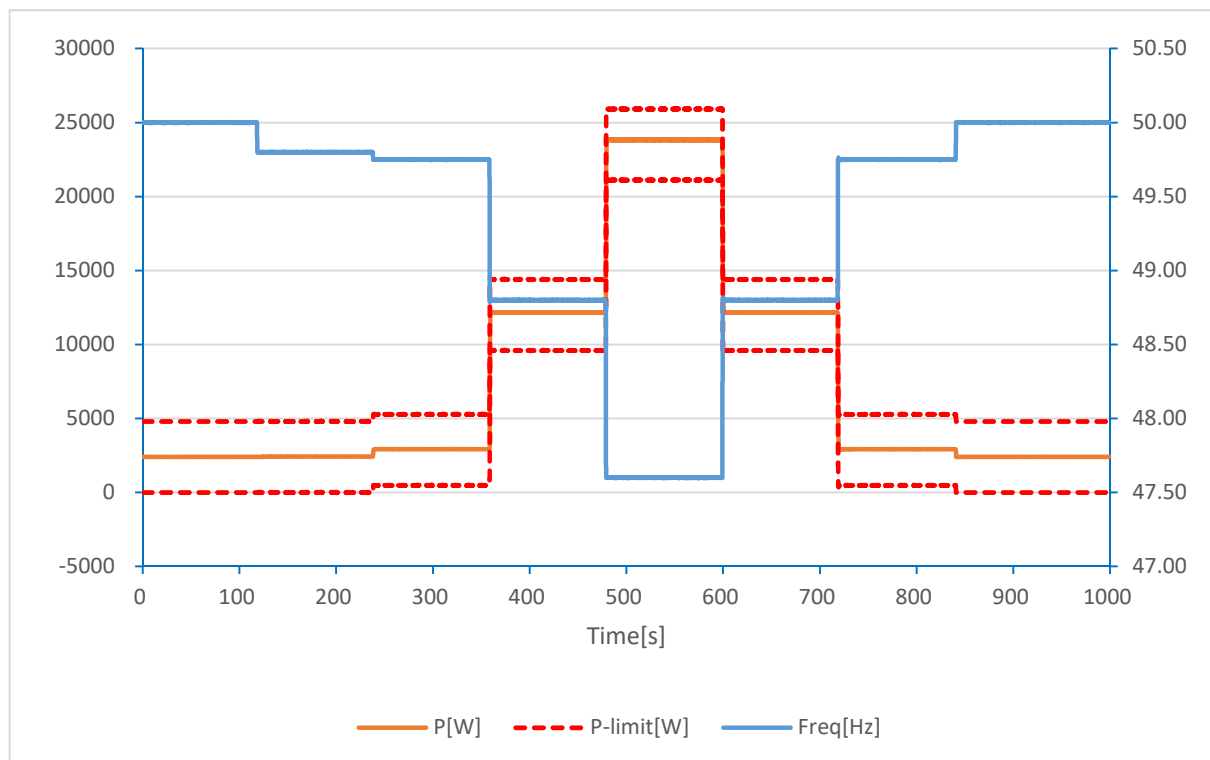
The test method refer to clause 5.4.4 of VDE V 0124-100:2019-02 (Draft).

The tests had been performed on the SOFAR 24KTLX-G3 is valid for the SOFAR 15KTLX-G3, SOFAR 17KTLX-G3, SOFAR 20KTLX-G3 and SOFAR 22KTLX-G3, since it is identical in hardware and software construction except output power derated by software.

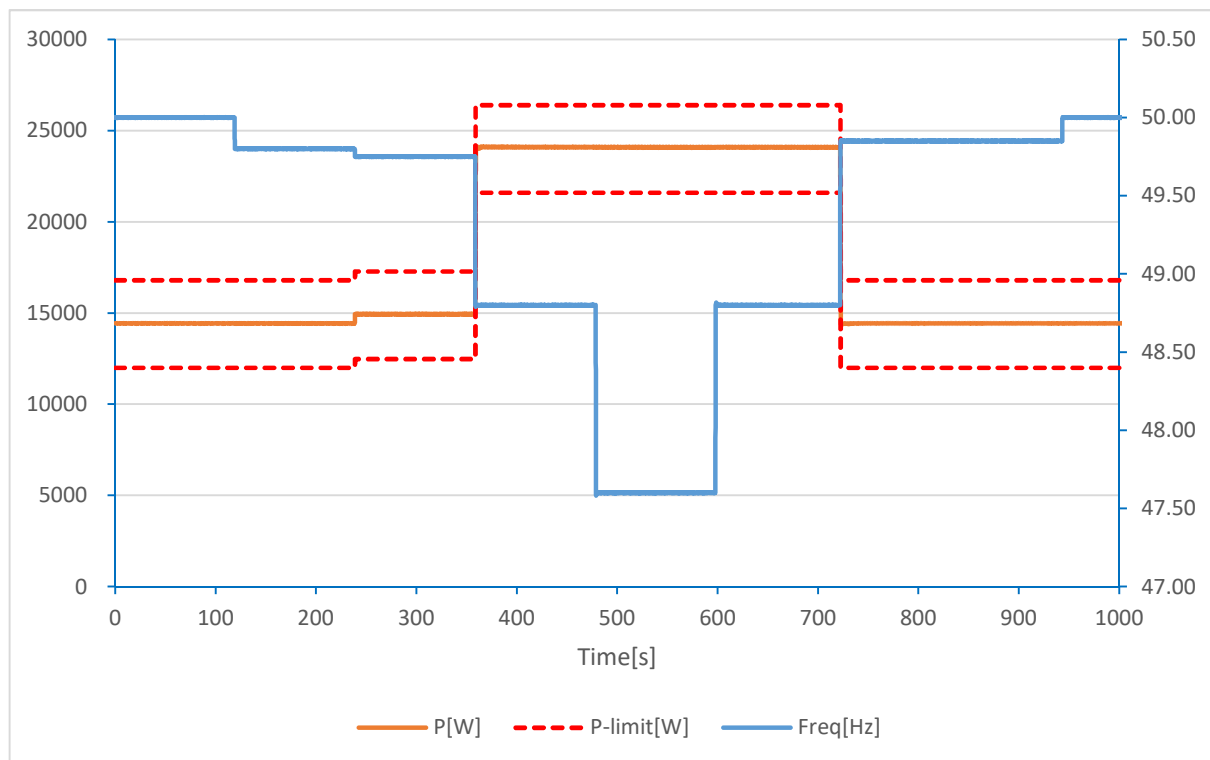


4.6.2 Power response to Under-frequency (For all other synchronous generating unit only if applicable)								P
<b>Test result:</b>								
1-min mean value [Hz]:	a) 50,00	b) 49,75	c) 48,80	d) 47,60	e) 48,80	f) 49,85	g) 50,00	
2. Measurement a) to g): Active power output = 10% P <sub>E<sub>max</sub></sub> s=5% (40% P <sub>ref</sub> / Hz), threshold frequency for start/return: 49,8Hz								
Frequency [Hz]:	50,00	49,80	49,75	48,80	47,60	48,80	49,75	50,00
P <sub>M</sub> [kW]:	N/A	2,400	2,880	12,000	23,520	12,000	2,880	N/A
P <sub>E60</sub> [kW]:	2,391	2,421	2,913	12,151	23,828	12,152	2,913	2,400
ΔP <sub>E60</sub> /P <sub>M</sub> [%]:	N/A	-0,089	-0,139	-0,628	-1,283	-0,633	-0,139	N/A
<b>Test result:</b>								
1-min mean value [Hz]:	a) 50,00	b) 49,75	c) 48,80	d) 47,60	e) 48,80	f) 49,85	g) 50,00	
3. Measurement a) to g): Active power output = 60% P <sub>E<sub>max</sub></sub> s=5% (40% P <sub>ref</sub> / Hz), threshold frequency for start/return: 49,8Hz								
Frequency [Hz]:	50,00	49,75	48,80	47,60	48,80	49,85	50,00	
P <sub>M</sub> [kW]:	N/A	14,880	24,000	24,000	24,000	14,400	N/A	
P <sub>E60</sub> [kW]:	14,432	14,938	24,096	24,086	24,085	14,423	14,431	
ΔP <sub>E60</sub> /P <sub>M</sub> [%]:	N/A	0,242	0,400	0,356	0,354	0,098	N/A	
<b>Limit ΔP/P<sub>1min</sub>:</b>	± 10 % of P <sub>E<sub>max</sub></sub>							

**Graph of Measurement 2.: Active power output 10%  $\pm$ 5%  $P_{Emax}$**



**Graph of Measurement 3.: Active power output 60%  $\pm$ 5%  $P_{Emax}$**



**Test:**

The test is conducted for two powers. First, the test must start at a power =10%  $P_{E_{max}}$  ("Measurement 2"), and in a second test, for a power 60%  $P_{E_{max}}$  ("Measurement 3"). In the second and third test, after freezing of the  $P_M$ , the available active power output must be increased to a value =100%  $P_{E_{max}}$ .

**Assessment criterion:**

For  $f = 49,8$  Hz, the value of the  $P_M$  active power currently being generated is "frozen".

a) For adjustable micro-generators when:

- 1) the active power increase between measuring points b) and f) given above with the set gradient  $P_{max}$  per Hz for a reduces frequency (or rises for a frequency again).
- 2) the reaction value of the setpoint determined by the gradient characteristic curve does not differ from  $P_{E_{max}}$  by more than  $\pm 10\%$ .
- 3) the settling time is equal or below 2 s with an intentional delay set to zero

b) For partly adjustable micro-generators

- 1) when they behave as in a) within their adjustment range, and
- 2) when, outside the adjustable range, the power fed in on leaving the adjustment range remains constant until shutdown. Shutdown must be no later than at 47,5 Hz.

**Note:**

The test method refer to clause 5.4.6 of VDE V 0124-100:2019-02 (Draft).

The tests had been performed on the SOFAR 24KTLX-G3 is valid for the SOFAR 15KTLX-G3, SOFAR 17KTLX-G3, SOFAR 20KTLX-G3 and SOFAR 22KTLX-G3, since it is identical in hardware and software construction except output power derated by software.

## EN 50549-1:2019: Power response to voltage variations and voltage changes

Clause	Test requirement	Test procedure according standard	Result
4.7.2.2	Capabilities	--	<b>P</b>
4.7.2.3.2	Fix control modes ( <u>cos <math>\phi</math> setpoint mode</u> )	FGW TG3, Revision 25, clause 4.2.2	<b>P</b>
4.7.2.3.2	Fix control modes ( <u>Q setpoint mode, 48,43%</u> )	EN 50438:2013, Annex D.3.4.2.1	<b>P</b>
4.7.2.2	Q Response time	CEI 0-21:2019-04, Annex B.1.2.4	<b>P</b>
4.7.2.3.3	Voltage related control modes (Q (U) controls)	VDE AR 4105:2018-05, clause 5.7.2.4.	<b>P</b>
4.7.2.3.4	Power related control modes (cos $\phi$ (P) curve)	VDE V 0124-100:2012, clause 5.3.6.4	<b>P</b>
4.7.3	Voltage related active power reduction (P(U) function)	CEI 0-21:2019-04, Annex B.1.3.1	<b>P</b>

4.7.2 Voltage support by reactive power				P
4.7.2.2 Capabilities				
4.7.2.3.2 Fix control modes (cos φ setpoint mode)				
<b>Test result:</b>				
<b>PF = 0,9 / Inductive reactive power supply</b>				
Rating power [%]	Active power [kW]	Reactive power [kVar]	Power factor [cos φ]	Voltage [V]
10%	2,391	-1,174	0,8977	230,10
20%	4,828	-2,270	0,9050	230,15
30%	7,247	-3,590	0,8960	230,27
40%	9,663	-4,770	0,8967	230,34
50%	12,067	-5,942	0,8971	230,46
60%	14,464	-7,117	0,8973	230,51
70%	16,860	-8,284	0,8975	230,61
80%	19,236	-9,436	0,8978	230,72
90%	21,600	-10,581	0,8980	230,81
100%	23,957	-11,665	0,8991	230,93
<b>PF = 0,9 / Capacitive reactive power supply</b>				
Rating power [%]	Active power [kW]	Reactive power [kVar]	Power factor [cos φ]	Voltage [V]
10%	2,397	1,188	0,8959	230,18
20%	4,835	2,260	0,9059	230,27
30%	7,258	3,535	0,8991	230,35
40%	9,679	4,657	0,9011	230,44
50%	12,088	5,781	0,9021	230,54
60%	14,490	6,931	0,9021	230,65
70%	16,880	8,073	0,9021	230,77
80%	19,263	9,213	0,9021	230,86
90%	21,635	10,346	0,9022	230,94
100%	23,993	11,468	0,9022	231,01

**Cos phi=1 no reactive power supply**

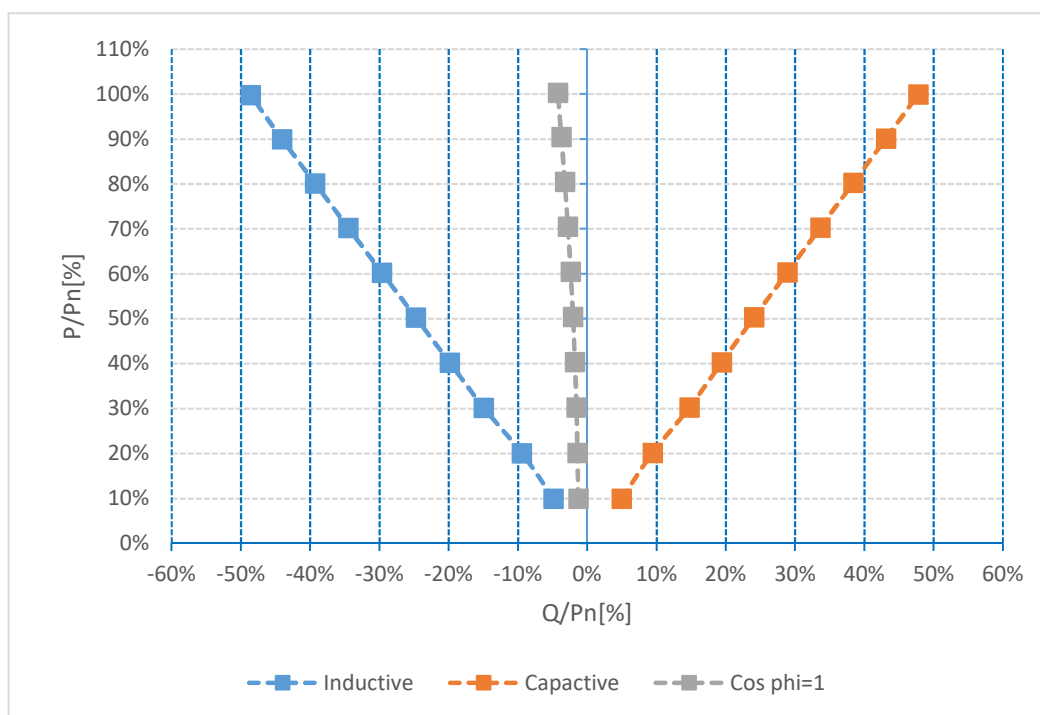
Rating power [%]	Active power [kW]	Reactive power [kVar]	Power factor [cos φ]	Voltage [V]
10%	2,394	-0,317	0,9999	230,10
20%	4,839	-0,342	0,9999	230,22
30%	7,268	-0,379	0,9999	230,31
40%	9,694	-0,432	0,9999	230,40
50%	12,111	-0,495	0,9999	230,51
60%	14,523	-0,576	0,9999	230,62
70%	16,928	-0,676	0,9999	230,73
80%	19,322	-0,782	0,9999	230,81
90%	21,707	-0,900	0,9999	230,92
100%	24,082	-1,024	0,9999	231,00

**Assessment criterion:**

The power factor resulting in each of the measurement points between 20 % and 90 % of the nominal power is equal to or lower than 0,90 both in over excited and under excited operation.

The tests had been performed on the SOFAR 24KTLX-G3 is valid for the SOFAR 15KTLX-G3, SOFAR 17KTLX-G3, SOFAR 20KTLX-G3 and SOFAR 22KTLX-G3, since it is identical in hardware and software construction except output power derated by software.

**Diagram**



4.7.2 Voltage support by reactive power				P
4.7.2.2 Capabilities				
4.7.2.3.2 Fix control modes (Q setpoint mode, 48,43%)				
<b>Test result:</b>				
<b>Inductive reactive power supply</b>				
Rating power [%]	Active power [kW]	Reactive power [kVar]	Power factor [cos φ]	Voltage [V]
10%	2,364	-11,848	0,1957	230,01
20%	4,816	-11,903	0,3751	230,17
30%	7,237	-11,954	0,5179	230,29
40%	9,660	-12,025	0,6263	230,41
50%	12,080	-11,868	0,7133	230,48
60%	14,478	-11,932	0,7717	230,62
70%	16,875	-11,879	0,8177	230,69
80%	19,270	-11,947	0,8499	230,81
90%	21,648	-11,904	0,8763	230,91
100%	23,406	-11,874	0,8918	230,96
<b>Capacitive reactive power supply</b>				
Rating power [%]	Active power [kW]	Reactive power [kVar]	Power factor [cos φ]	Voltage [V]
10%	2,383	11,886	0,1966	230,17
20%	4,841	11,819	0,3790	230,25
30%	7,260	11,731	0,5262	230,34
40%	9,692	11,767	0,6358	230,44
50%	12,108	11,817	0,7156	230,54
60%	14,516	11,873	0,7741	230,65
70%	16,919	11,817	0,8198	230,74
80%	19,281	11,877	0,8514	230,74
90%	21,674	11,817	0,8780	230,89
100%	23,235	11,924	0,8897	230,98
<b>Cos phi=1 no reactive power supply</b>				
Rating power [%]	Active power [kW]	Reactive power [kVar]	Power factor [cos φ]	Voltage [V]
10%	2,394	-0,317	0,9999	230,10
20%	4,839	-0,342	0,9999	230,22
30%	7,268	-0,379	0,9999	230,31
40%	9,694	-0,432	0,9999	230,40
50%	12,111	-0,495	0,9999	230,51
60%	14,523	-0,576	0,9999	230,62
70%	16,928	-0,676	0,9999	230,73
80%	19,322	-0,782	0,9999	230,81
90%	21,707	-0,900	0,9999	230,92
100%	24,082	-1,024	0,9999	231,00

**Assessment criterion:**

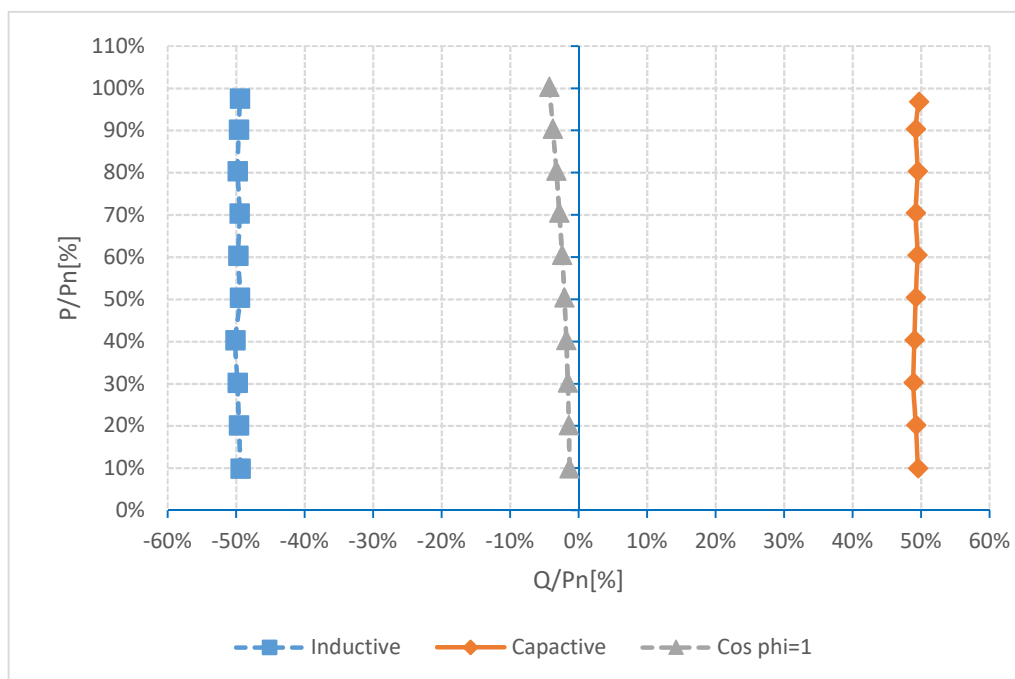
The power factor resulting in each of the measurement points between 20 % and 90 % of the nominal power is equal to or lower than 0,90 both in over excited and under excited operation,

The test method refer to clause CEI0-21 / EN 50438:2013, Annex D,3,4,2,1,

Generating plants must meet the reactive power requirement regardless of the number of feeding phases under normal steady-state operating conditions in the voltage tolerance band +10%U<sub>n</sub> and -15%U<sub>n</sub>.

The tests had been performed on the SOFAR 24KTLX-G3 is valid for the SOFAR 15KTLX-G3, SOFAR 17KTLX-G3, SOFAR 20KTLX-G3 and SOFAR 22KTLX-G3, since it is identical in hardware and software construction except output power derated by software.

**Diagram**





<b>4.7.2.2</b>	<b>Capabilities</b> <b>Q Response time</b>	<b>P</b>
----------------	---	----------

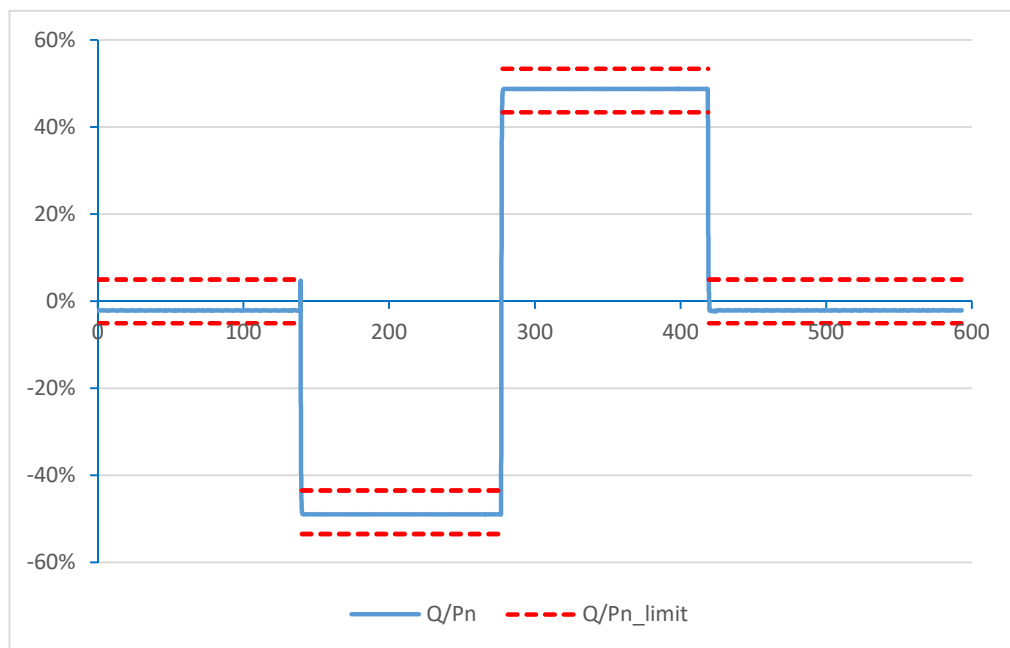
**Reaction time**

**Test result:**

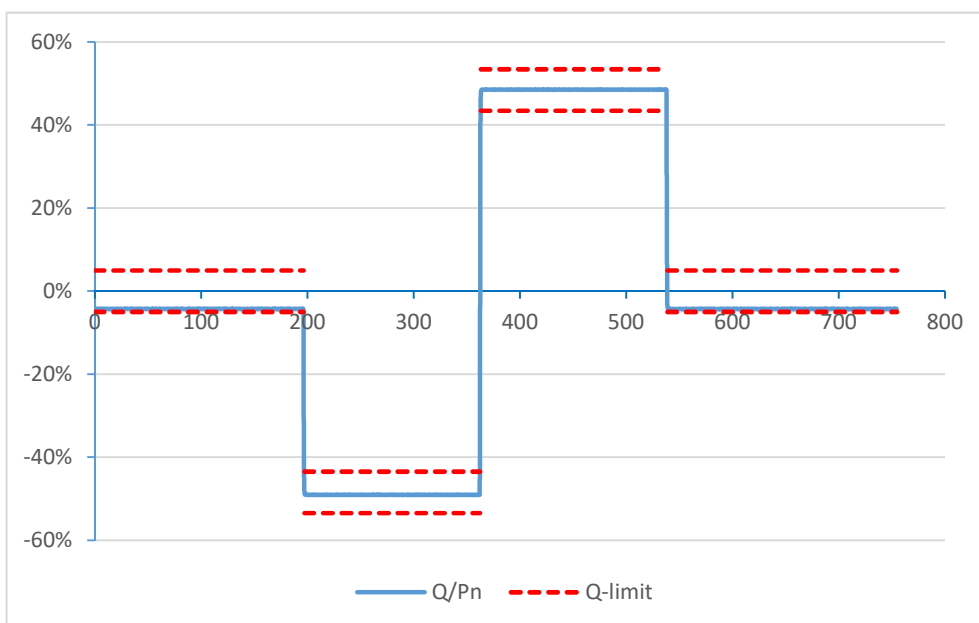
		<b>Time</b>	<b>Result</b>
1.	Reaction time Q=0 to Qmin (50% test)	0,6s	P
2.	Reaction time Qmin to Qmax (50% test)	1,2s	P
3.	Reaction time Qmax to Q=0 (50% test)	0,6s	P
4.	Reaction time Q=0 to Qmin (100% test)	0,6s	P
5.	Reaction time Qmin to Qmax (100% test)	1,2s	P
6.	Reaction time Qmax to Q=0 (100% test)	0,6s	P

**Test result:**

**Graph 50%Pn**



**Graph 100%Pn**



**Assessment criterion:**

DC source should be set to 50%(test1) and 100%(test2) output power micro-generator.

Starting with  $Q=0$  then  $Q_{min} \leq -0,4843 P_n$  to to  $Q_{max} \geq 0,4843 P_n$ , and then back to  $Q=0$  in doing so each point must be kept for at least 2 minute.

The total tolerance is  $\Delta Q \leq \pm 5,0\%$  of  $P_n$  or  $\Delta \cos\phi \leq \pm 0,01$

The maximum response time is 10s.

The tests had been performed on the SOFAR 24KTLX-G3 is valid for the SOFAR 15KTLX-G3, SOFAR 17KTLX-G3, SOFAR 20KTLX-G3 and SOFAR 22KTLX-G3, since it is identical in hardware and software construction except output power derated by software.

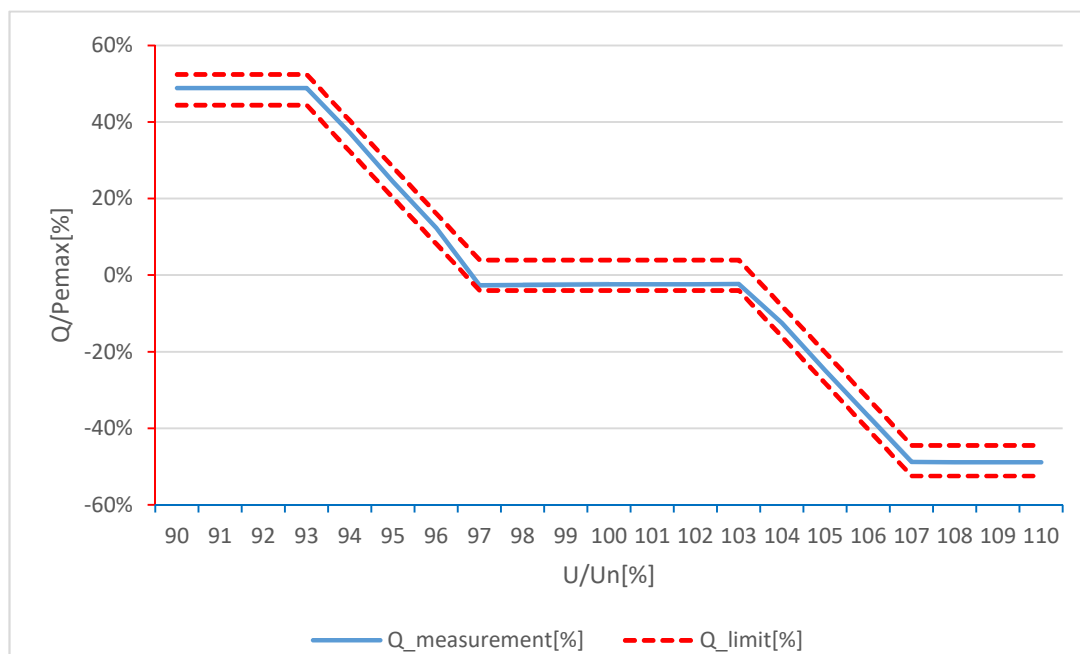
4.7.2.2 Capabilities						P
4.7.2.3.3 Voltage related control modes (Q (U) controls)						
The validation of the Q (U) regulation according to VDE-AR-N 4105: 2018-05, 5.7.2.4 is divided into two partial tests, so that on the one hand the accuracy and on the other hand the dynamics of the Q (U) control is checked. For all inverter-coupled systems, only the inverter must be tested.						
<b>Test result:</b>						
Test of the reactive power-voltage characteristic Q (U)						P
Vac [% U <sub>n</sub> ] Set point	Vac [V] measured	P [kW] measured	Q [kVar] measured	Q [kVar] expected	ΔQ [% P <sub>E</sub> max]	
100	230,21	24,039	-0,573	0	2,39	
99	227,98	24,036	-0,582	0	2,43	
98	225,69	24,029	-0,609	0	2,54	
97	223,37	24,018	-0,648	0	2,70	
96	220,82	24,003	2,976	2,906	-0,29	
95	218,64	23,973	5,854	5,812	-0,18	
94	216,33	23,277	8,749	8,717	-0,13	
93	214,07	21,658	11,488	11,623	0,56	
92	211,78	21,304	11,720	11,623	-0,40	
91	209,48	21,073	11,722	11,623	-0,41	
90	207,30	20,856	11,721	11,623	-0,41	
91	209,46	21,073	11,719	11,623	-0,40	
92	211,78	21,305	11,716	11,623	-0,39	
93	214,08	21,536	11,715	11,623	-0,38	
94	216,29	23,202	8,925	8,717	-0,87	
95	218,73	23,959	5,851	5,812	-0,16	
96	220,89	23,990	2,949	2,906	-0,18	
97	223,37	24,011	-0,631	0	2,63	
98	225,72	24,021	-0,605	0	2,52	
99	228,03	24,027	-0,585	0	2,44	
100	230,28	24,029	-0,578	0	2,41	
101	232,61	24,031	-0,571	0	2,38	
102	234,85	24,033	-0,567	0	2,36	
103	237,18	24,035	-0,561	0	2,34	
104	239,46	24,026	-3,006	-2,906	0,42	
105	241,62	24,004	-5,964	-5,812	0,63	
106	243,84	23,970	-8,829	-8,717	0,47	

107	246,08	23,263	-11,716	-11,623	0,39
108	248,49	23,243	-11,735	-11,623	0,47
109	250,72	23,239	-11,735	-11,623	0,47
110	253,11	23,225	-11,736	-11,623	0,47
109	250,70	23,251	-11,716	-11,623	0,39
108	248,55	23,261	-11,715	-11,623	0,38
107	246,15	23,266	-11,715	-11,623	0,38
106	243,96	23,956	-8,957	-8,717	1,00
105	241,63	23,995	-5,969	-5,812	0,65
104	239,43	24,019	-2,993	-2,906	0,36
103	237,19	24,029	-0,566	0	2,36
102	234,89	24,027	-0,569	0	2,37
101	232,51	24,026	-0,574	0	2,39
100	230,31	24,024	-0,580	0	2,42

Limit  $\Delta Q$ :

$\pm 4\% P_{E_{max}}$

**Graph of characteristic Q (U):**



**Test:**

The verification of the accuracy of the Q (U) control of the reactive power-voltage characteristic  $U_n$  shown in VDE-AR-N 4105: 2018-11, 5.7.2.4, Figure 7 is effected by a slow variation of the line voltage  $U_n$  in the range 90%  $U_n$  to 110%  $U_n$ . Depending on the type of EZE (single- or three-phase), the voltage changes must be carried out simultaneously or symmetrically on all phases.

a) In order to check the stationary accuracy, the permissible voltage range shall be passed through within steps, with a step size of 1%  $U_n$ , but not greater than 2%  $U_n$ .

1. Pass the voltage range from 100%  $U_n$  down to the under voltage range to 90%  $U_n$ .
2. Pass the voltage range from 90%  $U_n$  up to the over voltage range to 110%  $U_n$ .
3. Pass the voltage range from 110%  $U_n$  down to the Nominal Voltage  $U_n$ .

The procedure is analogous to Figure 3 in Section 5.4.3.2.

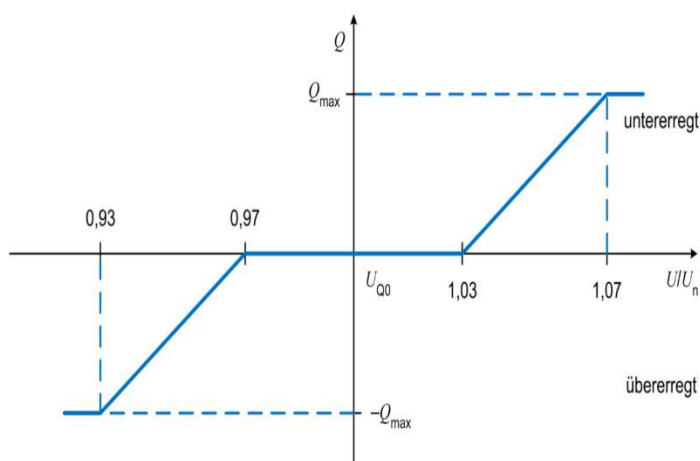
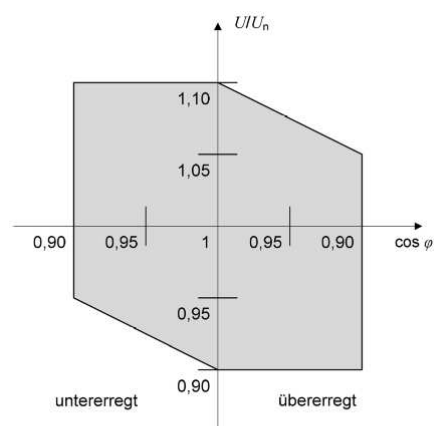


Bild 7 – Standard-Q(U)-Kennlinie



**Bild 3 – Anforderungen an Erzeugungseinheiten bezüglich der Blindleistungsbereitstellung an den Generatorklemmen**  
( $\sum S_{E_{max}} > 4,6 \text{ kVA}$ )

The voltages are to be set with a maximum deviation of 0.25%  $U_n$ .

**Assessment criterion:**

In order to pass the Q (U) accuracy test, the measured stationary value pairs  $U_{PGU}$  and  $Q_{PGU}$ , under taking account to the correct sign in the consumer metering system, must be within VDE-AR-N 4105: 2018-11, in 5.7.2.4, Figure 7 Q (U) shown characteristic. The stationary value pairs  $U_{PGU}$  and  $Q_{PGU}$  are determined by averaging over 30 seconds at the end of the respective measuring section analogously to Chapter 5.4.3.2. The permissible deviations are with the maximum measuring error of the voltage of 1%  $U_n$  stated in VDE-AR-N 4105: 2018-11 and a setting accuracy of 4%  $P_{EMax}$  at

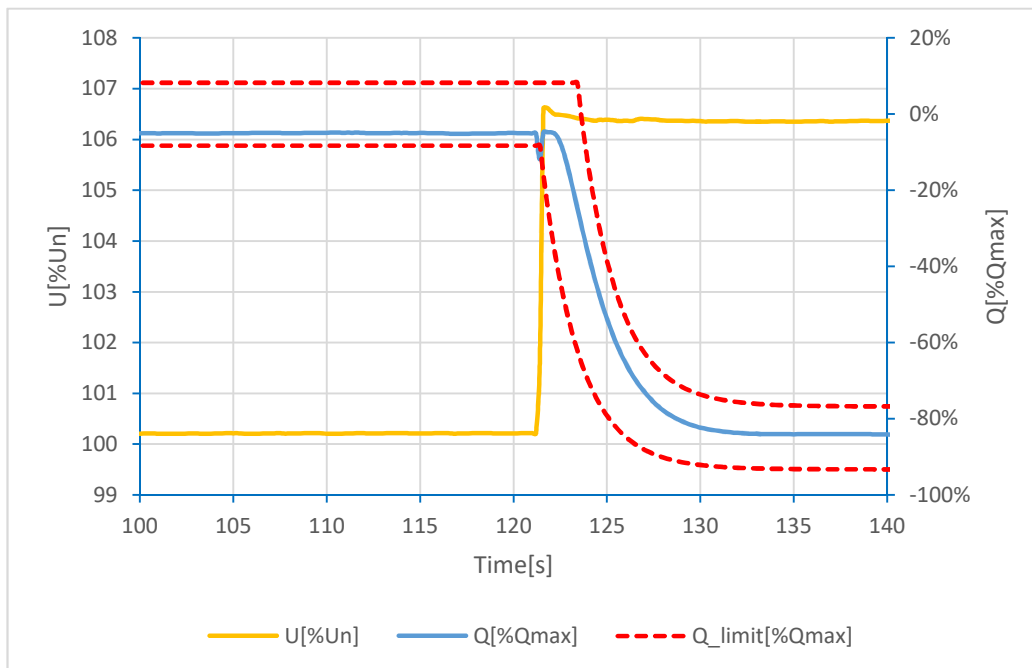
$$Q_{EZE,tot} = \pm(0.01 \cdot U_{N,Y} \cdot k_{QU} + 0.04 \cdot P_{EMax}) = \pm 0,25 \cdot P_{EMax} \cdot (\sin(\arccos(\varphi_{min})) + 0.16).$$

The tests had been performed on the SOFAR 24KTLX-G3 is valid for the SOFAR 15KTLX-G3, SOFAR 17KTLX-G3, SOFAR 20KTLX-G3 and SOFAR 22KTLX-G3, since it is identical in hardware and software construction except output power derated by software.

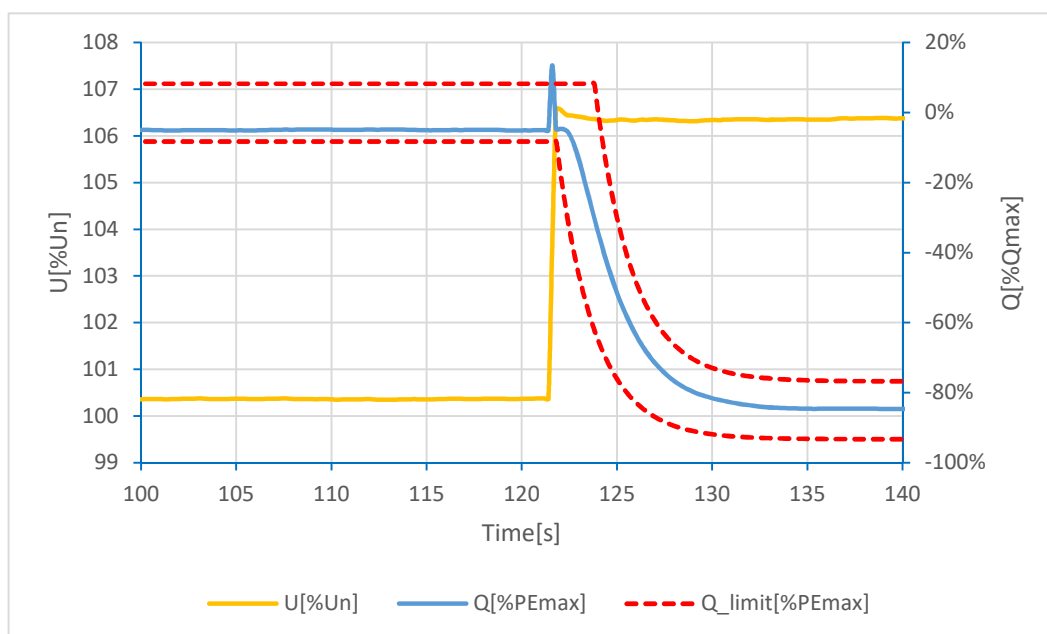
Test of the dynamics of the Q (U) regulation				P
Voltage jump Vac [% U <sub>n</sub> ]	Q [kVar] measured	Q [%Q <sub>max</sub> ] measured	T=3τ <sub>measured</sub>	
100 to 106,4	-9,993	-85,98	10,0 s	
	-9,849	-84,74	11,0 s	
	-9,928	-85,42	10,4 s	
100 to 93,6	9,887	85,06	10,2 s	
	9,871	84,92	11,2 s	
	9,895	85,13	11,6 s	

**Note:**  
The tests had been performed on the SOFAR 24KTLX-G3 is valid for the SOFAR 15KTLX-G3, SOFAR 17KTLX-G3, SOFAR 20KTLX-G3 and SOFAR 22KTLX-G3, since it is identical in hardware and software construction except output power derated by software.

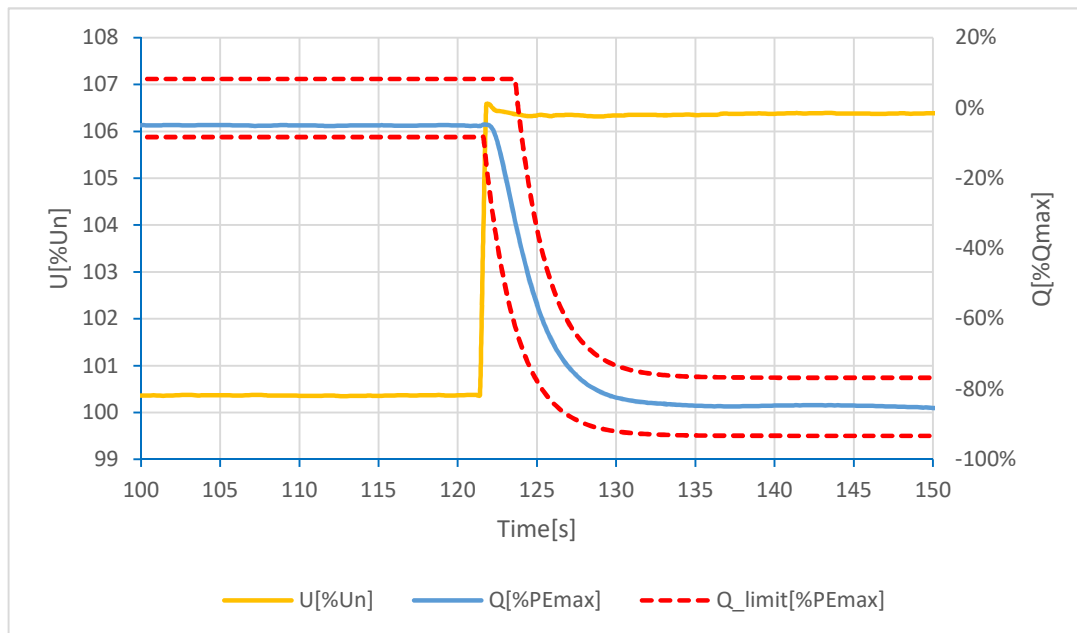
**Graph of 100%U<sub>n</sub> to 106,4% U<sub>n</sub>: Test 1**



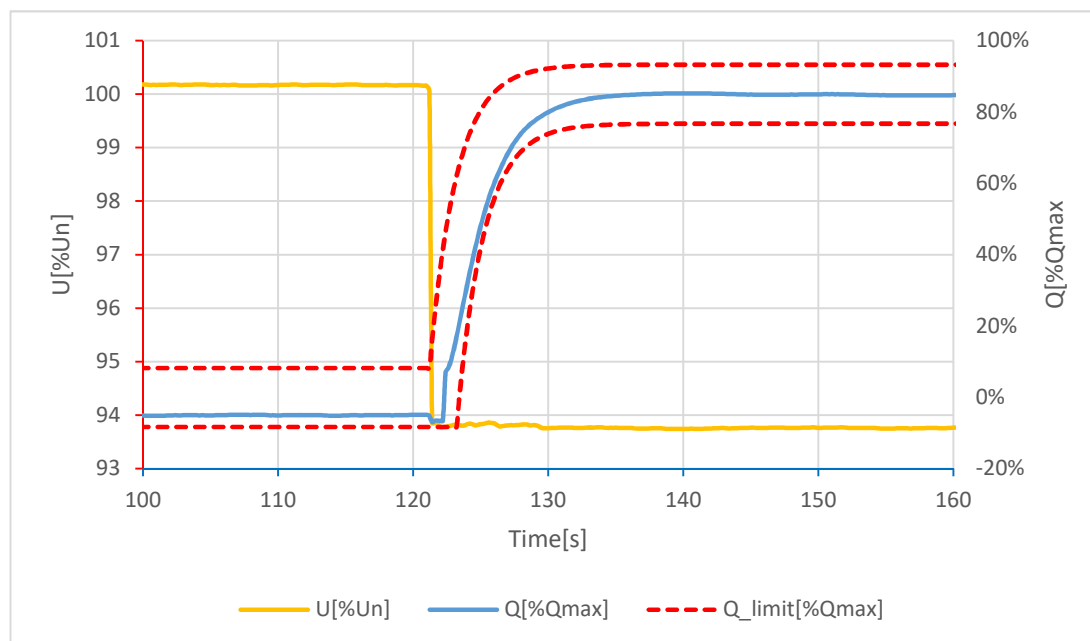
**Graph of 100%U<sub>n</sub> to 106,4% U<sub>n</sub>: Test 2**



**Graph of 100%U<sub>n</sub> to 106,4% U<sub>n</sub>: Test 3**

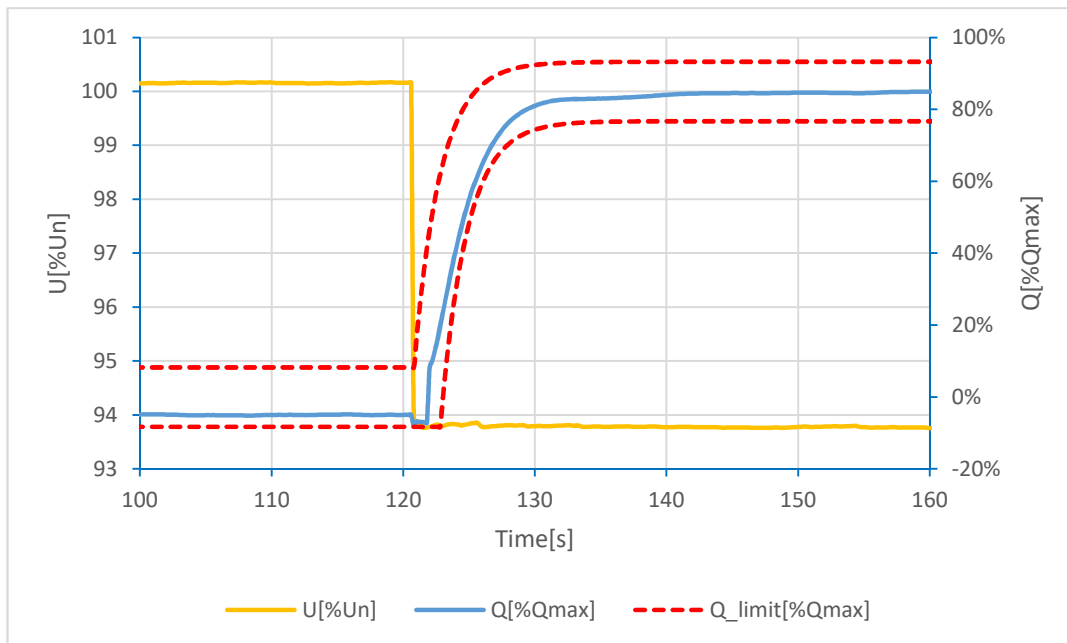


**Graph of 100%U<sub>n</sub> to 93,6% U<sub>n</sub>: Test 1**

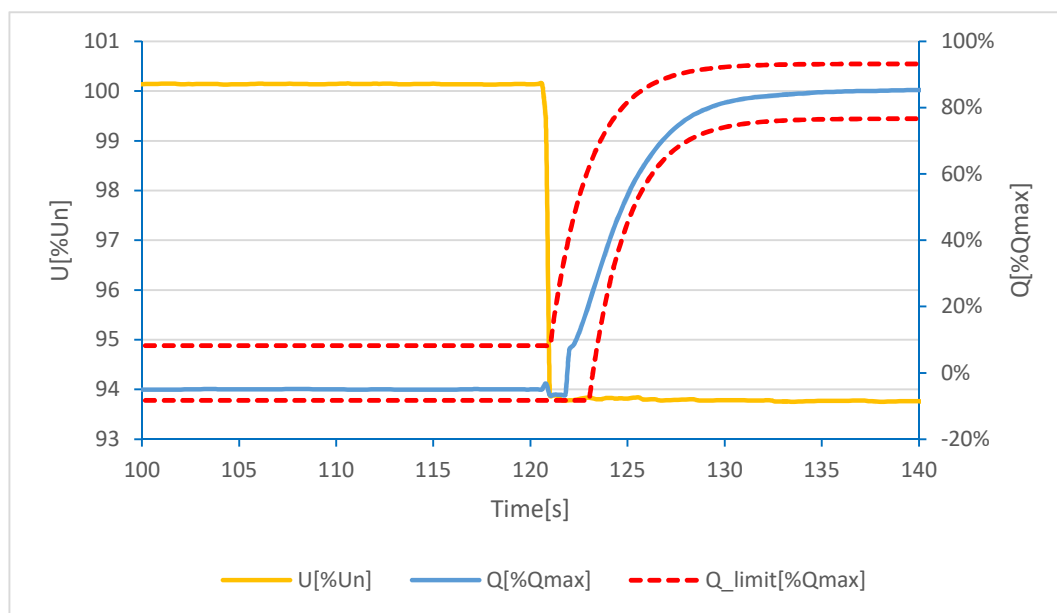




Graph of 100%U<sub>n</sub> to 93,6% U<sub>n</sub>: Test 2



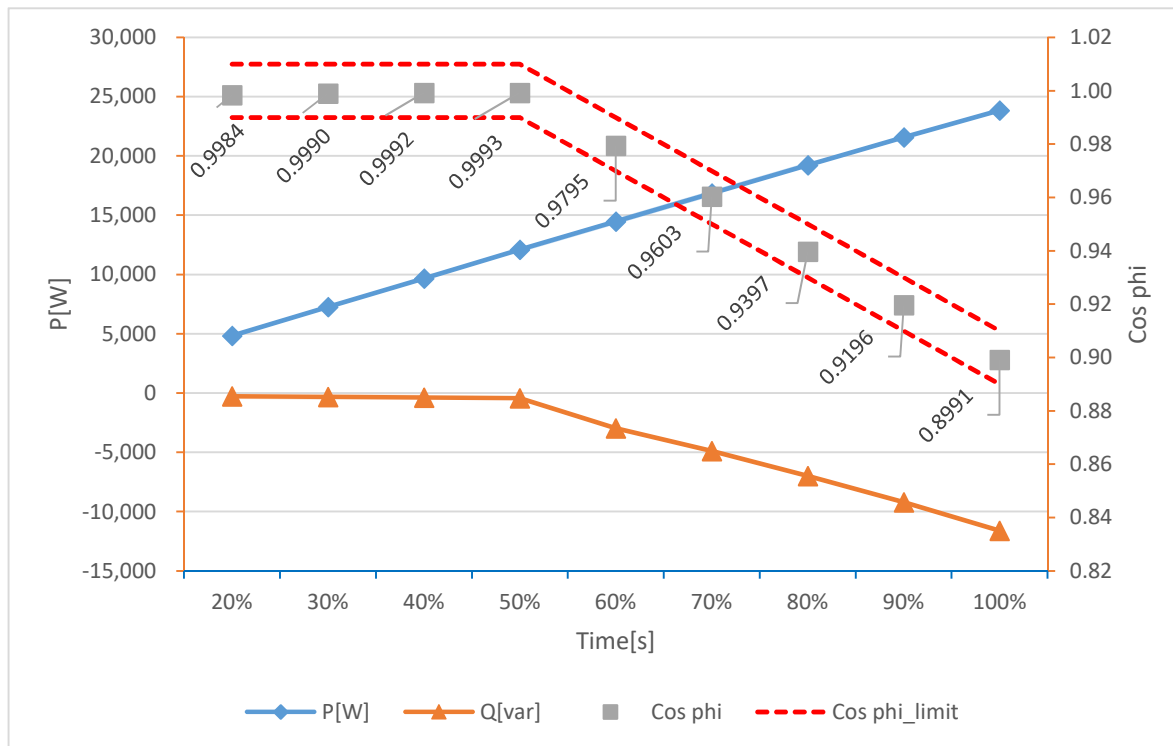
Graph of 100%U<sub>n</sub> to 93,6% U<sub>n</sub>: Test 3



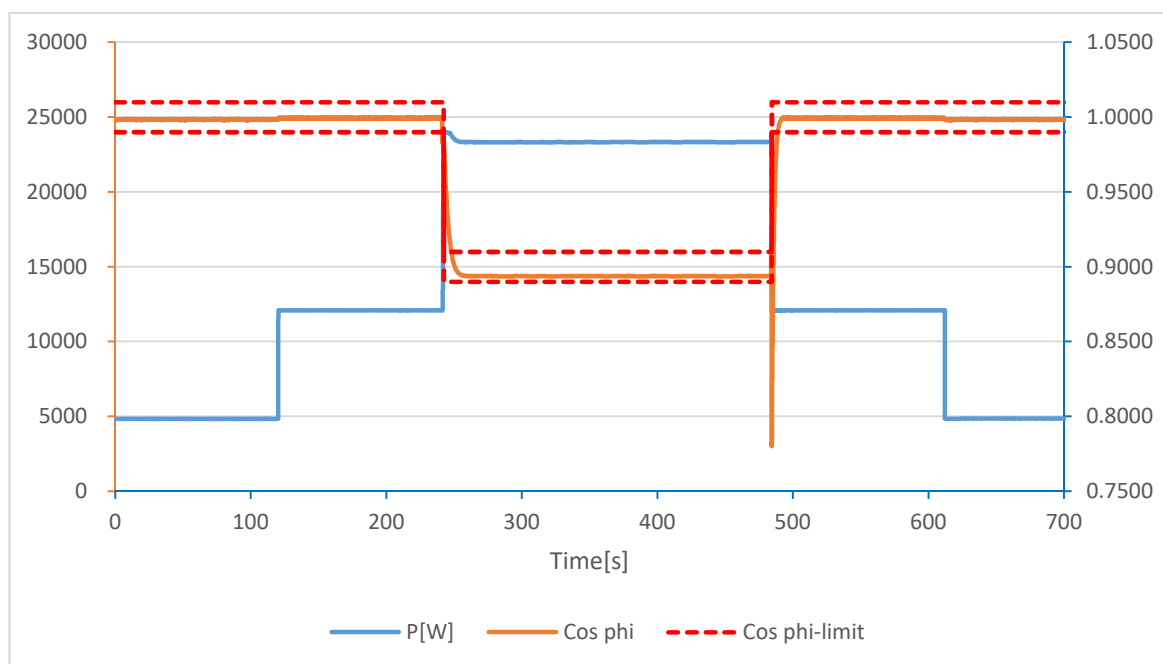
4.7.2.2 Capabilities										P
4.7.2.3.4 Power related Control mode (cos $\phi$ (P) curve)										
<b>Test result:</b>										
<b>Test a):</b>										
$P_{E_{max}}/P_n$ [%]	10	20	30	40	50	60	70	80	90	100
30 s mean value	20% to 100% $P_{E_{max}}$									
U [V]:	N/A	229,65	229,77	229,89	230,02	230,03	230,15	230,26	230,37	230,38
$P_{E30}$ [kW]:	N/A	4,843	7,263	9,673	12,084	14,469	16,848	19,213	21,563	23,851
$P_{E30}$ of $P_n$ [%]:	N/A	20,18	30,26	40,30	50,35	60,29	70,20	80,06	89,84	99,38
$Q_{E30}$ [kVAr]:	N/A	-0,267	-0,315	-0,371	-0,442	-2,976	-4,894	-6,989	-9,209	-11,611
cos $\phi_{E30}$ :	N/A	0,9984	0,9990	0,9992	0,9993	0,9795	0,9603	0,9397	0,9196	0,8991
cos $\phi_{setpoint}$ of $P_{E30}$ :	N/A	1,000	1,000	1,000	1,000	0,980	0,960	0,940	0,920	0,900
<b>Limit cos <math>\phi_{E30}</math>:</b>	cos $\phi_{setpoint} \pm 0,01$									
<b>Test b):</b>										
$P_{E_{max}}/P_n$ [%]	20			50			100			
30 s mean value	20% to 50% to 100% $P_{E_{max}}$									
U [V]:	230,34			230,64			231,08			
$P_{E30}$ [kW]:	4,838			12,084			23,319			
$P_{E30}$ of $P_n$ [%]:	20,16			50,35			97,16			
$Q_{E30}$ [kVAr]:	-0,263			-0,433			-11,709			
cos $\phi_{E30}$ :	0,9984			0,9993			0,8937			
cos $\phi_{setpoint}$ of $P_{E30}$ :	1,0			1,0			0,90			
$T_0$ [s]:	0,6 s					6,6 s				
$P_{E_{max}}/P_n$ [%]	100			50			20			
30 s mean value	100% to 50% to 20% $P_{E_{max}}$									
U [V]:	231,08			230,34			230,03			
$P_{E30}$ [kW]:	23,319			12,084			4,848			
$P_{E30}$ of $P_n$ [%]:	97,16			50,35			20,20			
$Q_{E30}$ [kVAr]:	-11,709			-0,446			-0,274			
cos $\phi_{E30}$ :	0,8937			0,9993			0,9984			
cos $\phi_{setpoint}$ of $P_{E30}$ :	0,90			1,0			1,0			
$T_0$ [s]:	6,0 s					0,6 s				
<b>Limit <math>T_0</math> [s]:</b>	10 s									
<b>Limit cos <math>\phi_{E30}</math>:</b>	cos $\phi_{setpoint} \pm 0,02$									

**Test result:**

**Graph of cos φ(P): Test a)**



**Graph of setting (T<sub>0</sub>) time: Test b): 20% to 50% to 100% to 50% to 20%**

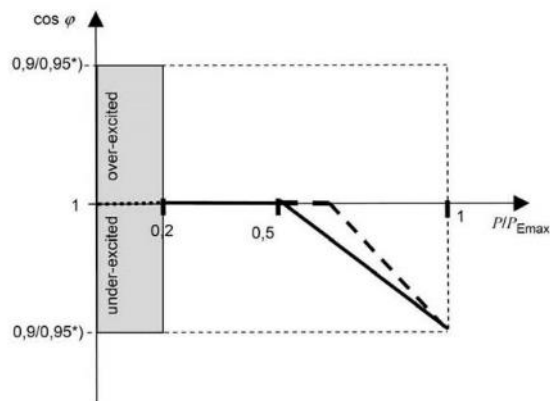


**Test:**

Test 1: Using the standard characteristic curve increases the active power from 20%  $P_{E_{max}}$  in increments of 10%  $P_{E_{max}}$  to  $P_{E_{max}}$ , The test is carried out in reverse.

Test 2: Using the standard characteristic curve increases the active power from 20%  $P_{E_{max}}$  to 50%  $P_{E_{max}}$  and to  $P_{E_{max}}$ , The test is carried out in reverse, After the PGU has settled, the end value reached is determined as a 30 s mean value.

Characteristic curve  $\cos \varphi (P)$



\*) Depending on  $S_{Amax}$

**Assessment criterion:**

Test 1:  $\cos \varphi$  accuracy  $\cos \varphi (\pm 0,01)$

Test 2:  $\cos \varphi$  accuracy  $\cos \varphi (\pm 0,02)$

For the test to be passed, the  $\cos \varphi$  setpoint from the active power must be measured at the terminals of the PGU within a settling time of 10 s.

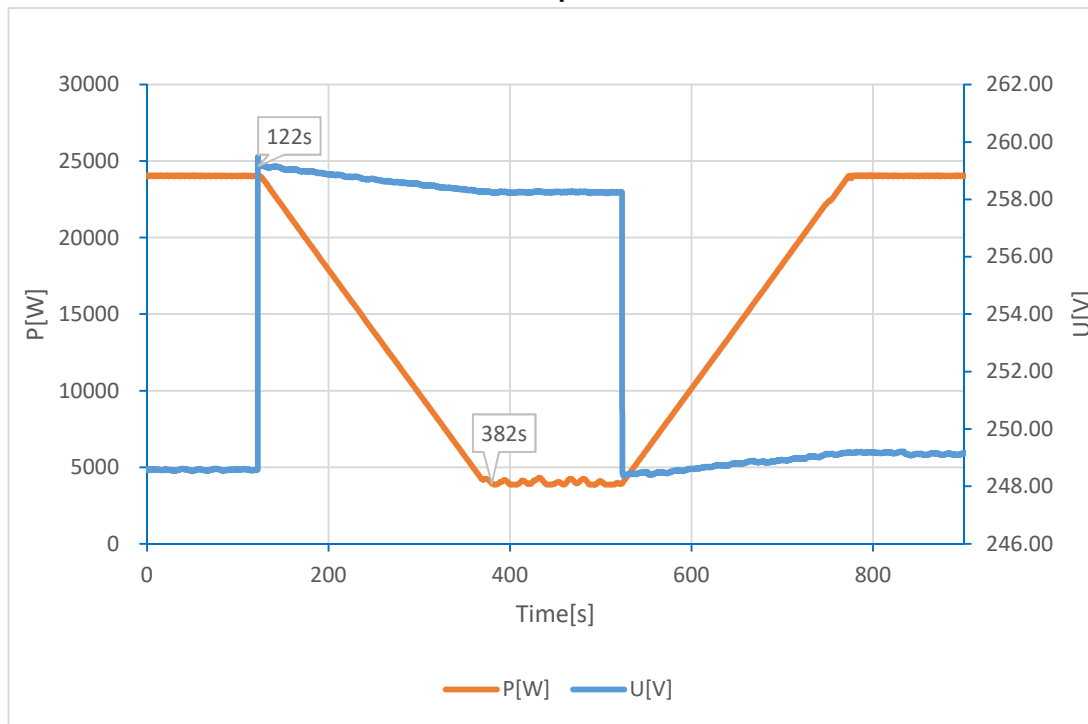
**Note:**

The test method refer to clause 5,3,6,4 of VDE V 0124-100:2012-07.

The tests had been performed on the SOFAR 24KTLX-G3 is valid for the SOFAR 15KTLX-G3, SOFAR 17KTLX-G3, SOFAR 20KTLX-G3 and SOFAR 22KTLX-G3, since it is identical in hardware and software construction except output power derated by software.

<b>4.7.3 Voltage related active power reduction (P(U) function)</b>		<b>P</b>
<b>Test result:</b>		
<b>Test:</b>		
5-min mean value / P / P <sub>n</sub> [%]	100% to 20%	
Settling time [s]:	547 s	
P <sub>E60</sub> [%]:	0,13%	
$\Delta P_{E60}/P_{Setpoint}$ [%]:	20 % or less of P <sub>E<sub>max</sub></sub>	
<b>Limit settling time:</b>	600s	
<p>Test:</p> <p>a) Set the voltage to 2% V<sub>n</sub> lower than the activation threshold stated by the manufacturer.</p> <p>b) Set the voltage to 112%V<sub>n</sub>, The inverter now has to reduce its output power to value lower than 20%P<sub>n</sub> within 5min.</p> <p>c) Set the voltage back to 2%V<sub>n</sub> lower than the activation threshold, Check that the active power will return to the value consistent with the power available from the primary source or simulated.</p> <p>The tests had been performed on the SOFAR 24KTLX-G3 is valid for the SOFAR 15KTLX-G3, SOFAR 17KTLX-G3, SOFAR 20KTLX-G3 and SOFAR 22KTLX-G3, since it is identical in hardware and software construction except output power derated by software.</p>		
<p><b>Assessment criterion:</b></p> <p>for adjustable PGUs:</p> <ul style="list-style-type: none"> <li>- no network disconnection</li> <li>- the active power value does not exceed the setpoint of 20% P<sub>E<sub>max</sub></sub></li> <li>- the setting time determined is equal or less than 600s</li> </ul>		

Graph:



### EN 50549-1:2019: Power quality

Clause	Test requirement	Test procedure according standard	Result
4.8	EMC and power quality	--	<b>P</b>
	Harmonic current emission	EN 61000-3-2, EN 61000-3-12	<b>P</b>
	Harmonic current emission	EN 61000-4-7	<b>P</b>
	Switching operations	IEC 61400-21	<b>P</b>
	Voltage fluctuation and flicker	EN 61000-3-3, EN 61000-3-11	<b>P</b>
	Flicker and voltage fluctuations	IEC 61400-21	<b>P</b>
	DC injection	EN 50438, Annex D,3,10	<b>P</b>
	Immunity to voltage dips and short interruptions	G59/3-4:2018-05, clause 13.8.4.5	<b>P</b>
	Unbalance	BDEW TG3, Revision 25, clause 4.3.5	<b>N/A</b>

4.8 EMC and power quality Harmonic current emission (EN 61000-3-12)								P
Test result: SOFAR 15KTLX-G3								
Watts [KW]				4,981/5,145/4,889				
Vrms [V]				230,80,230,74/230,76				
Arms [A]				21,590/22,307/21,196				
Frequency [Hz]				50,00				
THD50* (100% output power)				1,957/1,896/1,851				
Harmonic order n	Current Magnitude [A] at 100% rated output power			% of Fundamental			Phase	Harmonic Current Limits [%]
1st	21,580	22,297	21,186	-	-	-	Three Phase	--
2nd	0,006	0,004	0,005	0,029	0,018	0,023	Three Phase	8,000
3rd	0,080	0,014	0,079	0,370	0,061	0,371	Three Phase	21,600
4th	0,006	0,006	0,004	0,028	0,026	0,019	Three Phase	4,000
5th	0,296	0,293	0,264	1,372	1,315	1,247	Three Phase	10,700
6th	0,005	0,005	0,003	0,023	0,021	0,015	Three Phase	2,667
7th	0,172	0,173	0,165	0,797	0,775	0,781	Three Phase	7,200
8th	0,003	0,003	0,003	0,014	0,014	0,015	Three Phase	2,000
9th	0,009	0,007	0,019	0,044	0,030	0,087	Three Phase	3,800
10th	0,004	0,004	0,003	0,018	0,020	0,014	Three Phase	1,600
11th	0,099	0,101	0,071	0,460	0,455	0,335	Three Phase	3,100
12th	0,003	0,004	0,003	0,012	0,016	0,014	Three Phase	1,333
13th	0,044	0,047	0,038	0,204	0,210	0,181	Three Phase	2,000
14th	0,004	0,005	0,004	0,018	0,020	0,018	Three Phase	8,000
15th	0,009	0,005	0,006	0,041	0,024	0,029	Three Phase	N/A
16th	0,004	0,003	0,003	0,018	0,014	0,016	Three Phase	N/A
17th	0,076	0,092	0,081	0,351	0,412	0,380	Three Phase	N/A
18th	0,003	0,004	0,003	0,014	0,019	0,016	Three Phase	N/A
19th	0,123	0,134	0,126	0,568	0,599	0,597	Three Phase	N/A
20th	0,003	0,003	0,003	0,013	0,014	0,016	Three Phase	N/A
21th	0,005	0,009	0,009	0,025	0,042	0,044	Three Phase	N/A
22th	0,004	0,003	0,003	0,018	0,014	0,016	Three Phase	N/A
23th	0,028	0,021	0,025	0,130	0,093	0,116	Three Phase	N/A
24th	0,004	0,003	0,004	0,018	0,015	0,018	Three Phase	N/A
25th	0,089	0,095	0,089	0,410	0,427	0,420	Three Phase	N/A
26th	0,004	0,003	0,004	0,019	0,013	0,018	Three Phase	N/A
27th	0,006	0,010	0,008	0,028	0,045	0,040	Three Phase	N/A
28th	0,003	0,004	0,004	0,014	0,016	0,018	Three Phase	N/A
29th	0,047	0,047	0,045	0,219	0,211	0,215	Three Phase	N/A
30th	0,003	0,003	0,003	0,015	0,015	0,014	Three Phase	N/A
31th	0,071	0,079	0,073	0,329	0,353	0,345	Three Phase	N/A
32th	0,004	0,003	0,003	0,018	0,014	0,016	Three Phase	N/A
33th	0,006	0,007	0,006	0,027	0,032	0,029	Three Phase	N/A
34th	0,003	0,003	0,003	0,015	0,013	0,016	Three Phase	N/A
35th	0,054	0,053	0,048	0,250	0,239	0,227	Three Phase	N/A
36th	0,003	0,003	0,003	0,016	0,013	0,014	Three Phase	N/A
37th	0,030	0,032	0,031	0,141	0,144	0,148	Three Phase	N/A
38th	0,003	0,003	0,003	0,014	0,012	0,013	Three Phase	N/A
39th	0,006	0,006	0,005	0,026	0,027	0,026	Three Phase	N/A
40th	0,003	0,003	0,003	0,013	0,012	0,013	Three Phase	N/A
41th	0,032	0,031	0,028	0,150	0,138	0,132	Three Phase	N/A
42th	0,004	0,003	0,003	0,017	0,015	0,016	Three Phase	N/A
43th	0,008	0,009	0,010	0,037	0,041	0,045	Three Phase	N/A





44th	0,003	0,003	0,003	0,014	0,011	0,012	Three Phase	N/A
45th	0,006	0,005	0,004	0,026	0,022	0,021	Three Phase	N/A
46th	0,005	0,005	0,005	0,025	0,024	0,021	Three Phase	N/A
47th	0,022	0,020	0,019	0,101	0,091	0,092	Three Phase	N/A
48th	0,003	0,003	0,003	0,016	0,015	0,014	Three Phase	N/A
49th	0,008	0,009	0,010	0,039	0,041	0,046	Three Phase	N/A
50th	0,005	0,005	0,004	0,025	0,024	0,021	Three Phase	N/A

Test result: SOFAR 24KTLX-G3								
Watts [KW]				7,975/8,234/7,829				
Vrms [V]				230,79/230,80/230,82				
Arms [A]				34,569/35,691/33,931				
Frequency [Hz]				50,00				
THD50* (100% output power)				1,941/1,896/1,849				
Harmonic order n	Current Magnitude [A] at 100% rated output power			% of Fundamental			Phase	Harmonic Current Limits [%]
1st	34,553	35,675	33,915	-	-	-	Three Phase	--
2nd	0,009	0,006	0,007	0,026	0,017	0,020	Three Phase	8,000
3rd	0,120	0,022	0,125	0,348	0,061	0,368	Three Phase	21,600
4th	0,008	0,007	0,005	0,022	0,021	0,014	Three Phase	4,000
5th	0,470	0,468	0,422	1,362	1,310	1,246	Three Phase	10,700
6th	0,007	0,007	0,005	0,021	0,020	0,016	Three Phase	2,667
7th	0,276	0,281	0,264	0,798	0,788	0,777	Three Phase	7,200
8th	0,004	0,005	0,005	0,012	0,014	0,014	Three Phase	2,000
9th	0,012	0,012	0,027	0,034	0,033	0,081	Three Phase	3,800
10th	0,007	0,007	0,005	0,020	0,020	0,015	Three Phase	1,600
11th	0,156	0,161	0,116	0,450	0,451	0,343	Three Phase	3,100
12th	0,004	0,006	0,005	0,012	0,017	0,015	Three Phase	1,333
13th	0,069	0,075	0,061	0,198	0,211	0,180	Three Phase	2,000
14th	0,006	0,008	0,007	0,018	0,023	0,021	Three Phase	8,000
15th	0,014	0,008	0,009	0,040	0,024	0,026	Three Phase	N/A
16th	0,006	0,005	0,006	0,017	0,014	0,016	Three Phase	N/A
17th	0,125	0,149	0,128	0,362	0,418	0,377	Three Phase	N/A
18th	0,005	0,007	0,005	0,013	0,019	0,016	Three Phase	N/A
19th	0,196	0,214	0,205	0,567	0,600	0,603	Three Phase	N/A
20th	0,005	0,005	0,006	0,013	0,014	0,017	Three Phase	N/A
21th	0,009	0,014	0,015	0,026	0,040	0,044	Three Phase	N/A
22th	0,006	0,005	0,005	0,017	0,014	0,016	Three Phase	N/A
23th	0,044	0,029	0,040	0,127	0,082	0,117	Three Phase	N/A
24th	0,006	0,006	0,006	0,017	0,017	0,019	Three Phase	N/A
25th	0,140	0,151	0,142	0,406	0,423	0,420	Three Phase	N/A
26th	0,007	0,005	0,007	0,019	0,013	0,019	Three Phase	N/A
27th	0,010	0,015	0,014	0,029	0,043	0,040	Three Phase	N/A
28th	0,005	0,006	0,006	0,015	0,016	0,018	Three Phase	N/A
29th	0,074	0,074	0,073	0,215	0,207	0,215	Three Phase	N/A
30th	0,005	0,006	0,005	0,015	0,016	0,014	Three Phase	N/A
31th	0,113	0,125	0,117	0,327	0,350	0,344	Three Phase	N/A
32th	0,006	0,005	0,006	0,018	0,014	0,017	Three Phase	N/A
33th	0,010	0,012	0,010	0,029	0,034	0,031	Three Phase	N/A
34th	0,005	0,005	0,006	0,016	0,014	0,016	Three Phase	N/A
35th	0,085	0,084	0,075	0,245	0,235	0,222	Three Phase	N/A
36th	0,006	0,005	0,005	0,016	0,014	0,015	Three Phase	N/A
37th	0,049	0,051	0,049	0,141	0,144	0,145	Three Phase	N/A
38th	0,005	0,005	0,005	0,016	0,013	0,014	Three Phase	N/A
39th	0,010	0,011	0,010	0,028	0,031	0,029	Three Phase	N/A
40th	0,005	0,005	0,005	0,014	0,013	0,014	Three Phase	N/A
41th	0,051	0,048	0,044	0,147	0,135	0,129	Three Phase	N/A
42th	0,006	0,006	0,006	0,017	0,016	0,019	Three Phase	N/A
43th	0,013	0,014	0,015	0,039	0,040	0,043	Three Phase	N/A
44th	0,006	0,004	0,005	0,016	0,013	0,015	Three Phase	N/A
45th	0,010	0,008	0,008	0,030	0,024	0,024	Three Phase	N/A
46th	0,009	0,009	0,007	0,025	0,024	0,022	Three Phase	N/A

47th	0,034	0,032	0,030	0,098	0,090	0,088	Three Phase	N/A
48th	0,006	0,006	0,005	0,017	0,016	0,015	Three Phase	N/A
49th	0,013	0,015	0,016	0,038	0,042	0,047	Three Phase	N/A
50th	0,009	0,009	0,007	0,025	0,024	0,022	Three Phase	N/A

**Note:**

The tests should be based on the limits of the EN 61000-3-12 for more than 16A.

The tests had been performed on the SOFAR 24KTLX-G3 and SOFAR 15KTLX-G3 is valid for the SOFAR 17KTLX-G3, SOFAR 20KTLX-G3 and SOFAR 22KTLX-G3, since it is identical in hardware and software construction except output power derated by software.

4.8 EMC and power quality Harmonic current emission (EN 61000-4-7)											P
The currents of the interharmonics to 2 kHz must be measured in accordance with DIN EN 61000-4-7 (VDE 0817-4-7), Annex A, The measurements of higher-frequency harmonic currents between 2 kHz and 9 kHz must be conducted in line with DIN EN 61000-4-7 (VDE 0847-4-7), Annex B.											
<b>Test result: SOFAR 24KTLX-G3</b>											
<b>Harmonics</b>											
P/P <sub>n</sub> [%]	0	10	20	30	40	50	60	70	80	90	100
Order	I [%]	I [%]	I [%]	I [%]	I [%]	I [%]	I [%]	I [%]	I [%]	I [%]	I [%]
1	3,053	10,156	20,303	30,420	40,511	50,567	60,570	70,532	80,410	90,303	100,148
2	0,046	0,059	0,060	0,058	0,065	0,066	0,071	0,072	0,083	0,093	0,098
3	0,181	0,193	0,199	0,209	0,218	0,227	0,248	0,290	0,325	0,361	0,402
4	0,048	0,046	0,041	0,041	0,040	0,039	0,043	0,042	0,042	0,044	0,046
5	0,457	0,378	0,372	0,346	0,338	0,335	0,340	0,433	0,591	0,820	1,075
6	0,027	0,023	0,020	0,023	0,025	0,027	0,025	0,025	0,027	0,030	0,032
7	0,248	0,224	0,233	0,243	0,250	0,253	0,276	0,380	0,531	0,692	0,856
8	0,027	0,021	0,018	0,021	0,024	0,023	0,023	0,025	0,028	0,031	0,033
9	0,058	0,058	0,062	0,063	0,068	0,073	0,075	0,076	0,077	0,071	0,065
10	0,024	0,018	0,017	0,018	0,022	0,021	0,021	0,024	0,031	0,036	0,037
11	0,161	0,110	0,099	0,114	0,136	0,152	0,174	0,199	0,200	0,247	0,330
12	0,025	0,016	0,017	0,017	0,020	0,022	0,020	0,024	0,029	0,031	0,032
13	0,132	0,053	0,064	0,075	0,087	0,098	0,106	0,119	0,086	0,092	0,164
14	0,027	0,018	0,017	0,019	0,022	0,020	0,020	0,023	0,029	0,032	0,033
15	0,032	0,029	0,030	0,028	0,034	0,033	0,038	0,044	0,059	0,067	0,088
16	0,031	0,020	0,016	0,017	0,020	0,020	0,022	0,030	0,023	0,024	0,026
17	0,152	0,100	0,078	0,088	0,084	0,084	0,102	0,114	0,167	0,232	0,294
18	0,026	0,016	0,015	0,015	0,020	0,019	0,020	0,019	0,024	0,029	0,030
19	0,127	0,068	0,047	0,064	0,049	0,044	0,041	0,097	0,187	0,290	0,384
20	0,031	0,023	0,015	0,017	0,020	0,022	0,018	0,021	0,024	0,025	0,028
21	0,020	0,021	0,023	0,027	0,032	0,029	0,032	0,022	0,037	0,053	0,066
22	0,030	0,020	0,019	0,021	0,017	0,018	0,017	0,019	0,020	0,021	0,026
23	0,127	0,066	0,091	0,085	0,089	0,071	0,044	0,051	0,067	0,092	0,132
24	0,026	0,018	0,015	0,016	0,020	0,021	0,020	0,023	0,027	0,032	0,035
25	0,128	0,038	0,055	0,040	0,039	0,042	0,058	0,102	0,143	0,198	0,260
26	0,029	0,015	0,014	0,015	0,019	0,019	0,019	0,022	0,025	0,030	0,030
27	0,018	0,021	0,021	0,021	0,023	0,026	0,029	0,028	0,040	0,055	0,068
28	0,030	0,019	0,011	0,012	0,015	0,017	0,018	0,020	0,023	0,027	0,033
29	0,139	0,055	0,064	0,050	0,070	0,071	0,068	0,112	0,162	0,182	0,210
30	0,023	0,014	0,011	0,013	0,015	0,019	0,017	0,020	0,025	0,032	0,035
31	0,092	0,057	0,088	0,057	0,050	0,050	0,083	0,136	0,196	0,238	0,283
32	0,027	0,016	0,012	0,013	0,017	0,017	0,020	0,020	0,028	0,029	0,033
33	0,024	0,015	0,015	0,016	0,017	0,019	0,020	0,021	0,030	0,045	0,052
34	0,025	0,020	0,010	0,011	0,014	0,017	0,017	0,019	0,021	0,023	0,029
35	0,045	0,077	0,038	0,046	0,030	0,059	0,076	0,092	0,132	0,171	0,228
36	0,021	0,013	0,010	0,011	0,015	0,018	0,015	0,017	0,019	0,023	0,026
37	0,074	0,051	0,080	0,068	0,078	0,066	0,081	0,100	0,115	0,142	0,171



38	0,024	0,014	0,014	0,013	0,016	0,014	0,030	0,019	0,020	0,023	0,028
39	0,029	0,023	0,017	0,021	0,028	0,027	0,020	0,025	0,027	0,033	0,041
40	0,024	0,020	0,011	0,013	0,016	0,021	0,019	0,020	0,020	0,023	0,027
41	0,050	0,072	0,042	0,025	0,026	0,041	0,068	0,095	0,118	0,141	0,171
42	0,019	0,011	0,010	0,011	0,016	0,018	0,022	0,017	0,017	0,021	0,025
43	0,065	0,031	0,086	0,081	0,083	0,072	0,069	0,063	0,056	0,079	0,109
44	0,025	0,012	0,009	0,011	0,014	0,016	0,013	0,021	0,018	0,018	0,040
45	0,028	0,027	0,024	0,024	0,020	0,021	0,019	0,021	0,022	0,030	0,031
46	0,017	0,013	0,011	0,030	0,015	0,020	0,016	0,014	0,015	0,017	0,021
47	0,072	0,058	0,093	0,058	0,034	0,038	0,060	0,086	0,113	0,140	0,167
48	0,017	0,022	0,009	0,010	0,016	0,019	0,040	0,016	0,017	0,019	0,022
49	0,036	0,043	0,075	0,078	0,068	0,061	0,049	0,054	0,035	0,057	0,084
50	0,029	0,014	0,009	0,011	0,014	0,016	0,014	0,013	0,016	0,019	0,019

**Interharmonics**

P/P <sub>n</sub> [%]	0	10	20	30	40	50	60	70	80	90	100
f [Hz]	I [%]	I [%]	I [%]	I [%]	I [%]	I [%]	I [%]	I [%]	I [%]	I [%]	I [%]
75	0,070	0,062	0,080	0,128	0,161	0,197	0,245	0,273	0,321	0,359	0,386
125	0,030	0,027	0,030	0,046	0,057	0,065	0,077	0,082	0,100	0,108	0,113
175	0,034	0,028	0,038	0,049	0,044	0,050	0,059	0,062	0,072	0,078	0,081
225	0,072	0,034	0,034	0,043	0,049	0,049	0,061	0,062	0,069	0,073	0,076
275	0,079	0,036	0,063	0,042	0,039	0,043	0,043	0,048	0,052	0,050	0,056
325	0,071	0,034	0,054	0,040	0,040	0,045	0,043	0,047	0,050	0,052	0,052
375	0,093	0,033	0,033	0,040	0,040	0,039	0,038	0,043	0,043	0,043	0,044
425	0,031	0,026	0,033	0,036	0,037	0,042	0,043	0,042	0,046	0,044	0,041
475	0,033	0,026	0,033	0,035	0,037	0,041	0,041	0,040	0,044	0,045	0,044
525	0,071	0,026	0,034	0,037	0,040	0,042	0,040	0,043	0,048	0,047	0,045
575	0,081	0,028	0,035	0,042	0,038	0,044	0,042	0,047	0,045	0,048	0,045
625	0,075	0,035	0,036	0,047	0,042	0,046	0,054	0,052	0,057	0,052	0,054
675	0,075	0,031	0,044	0,045	0,044	0,050	0,049	0,051	0,048	0,054	0,048
725	0,035	0,035	0,032	0,043	0,040	0,041	0,049	0,050	0,069	0,078	0,054
775	0,038	0,032	0,045	0,041	0,040	0,045	0,049	0,062	0,048	0,047	0,060
825	0,062	0,046	0,034	0,049	0,043	0,045	0,062	0,065	0,071	0,057	0,060
875	0,070	0,038	0,053	0,048	0,044	0,054	0,068	0,057	0,052	0,063	0,050
925	0,070	0,034	0,031	0,036	0,036	0,038	0,046	0,046	0,051	0,046	0,053
975	0,082	0,035	0,034	0,034	0,038	0,057	0,043	0,050	0,046	0,051	0,048
1025	0,029	0,038	0,027	0,028	0,046	0,032	0,033	0,039	0,041	0,039	0,044
1075	0,031	0,027	0,032	0,044	0,031	0,032	0,034	0,037	0,039	0,039	0,042
1125	0,043	0,029	0,034	0,028	0,033	0,034	0,036	0,044	0,046	0,042	0,048
1175	0,049	0,030	0,025	0,028	0,033	0,036	0,038	0,041	0,042	0,048	0,048
1225	0,055	0,028	0,025	0,029	0,031	0,035	0,039	0,045	0,045	0,044	0,049
1275	0,060	0,024	0,022	0,025	0,030	0,033	0,039	0,045	0,047	0,050	0,051
1325	0,024	0,021	0,021	0,024	0,028	0,030	0,034	0,043	0,050	0,055	0,053
1375	0,025	0,020	0,021	0,023	0,027	0,029	0,034	0,040	0,047	0,049	0,056
1425	0,031	0,024	0,021	0,023	0,028	0,031	0,035	0,043	0,048	0,050	0,062
1475	0,035	0,024	0,019	0,023	0,026	0,031	0,036	0,042	0,049	0,053	0,055
1525	0,041	0,025	0,020	0,023	0,026	0,029	0,035	0,040	0,046	0,051	0,059
1575	0,043	0,024	0,018	0,020	0,025	0,027	0,036	0,039	0,051	0,051	0,058
1625	0,019	0,019	0,017	0,019	0,023	0,025	0,037	0,040	0,045	0,046	0,060



1675	0,021	0,017	0,017	0,019	0,025	0,029	0,031	0,034	0,046	0,054	0,054
1725	0,023	0,020	0,017	0,019	0,022	0,030	0,031	0,034	0,043	0,047	0,061
1775	0,027	0,021	0,017	0,018	0,021	0,028	0,031	0,034	0,040	0,051	0,055
1825	0,030	0,020	0,017	0,019	0,023	0,024	0,030	0,033	0,040	0,052	0,053
1875	0,034	0,017	0,021	0,017	0,023	0,022	0,033	0,054	0,063	0,074	0,084
1925	0,017	0,014	0,024	0,037	0,020	0,026	0,026	0,029	0,034	0,049	0,048
1975	0,018	0,022	0,013	0,018	0,035	0,022	0,028	0,029	0,033	0,039	0,045

**Higher Frequencies**

P/P <sub>n</sub> [%]	0	10	20	30	40	50	60	70	80	90	100
f [kHz]	I [%]	I [%]	I [%]	I [%]	I [%]	I [%]	I [%]	I [%]	I [%]	I [%]	I [%]
2,1	0,097	0,088	0,099	0,091	0,097	0,099	0,114	0,130	0,142	0,177	0,221
2,3	0,088	0,075	0,105	0,081	0,081	0,082	0,091	0,102	0,135	0,164	0,190
2,5	0,064	0,064	0,084	0,085	0,081	0,077	0,080	0,098	0,106	0,123	0,137
2,7	0,087	0,096	0,109	0,106	0,074	0,071	0,081	0,106	0,123	0,141	0,162
2,9	0,085	0,063	0,053	0,085	0,089	0,104	0,143	0,178	0,201	0,222	0,248
3,1	0,052	0,083	0,095	0,098	0,089	0,063	0,072	0,090	0,111	0,118	0,116
3,3	0,050	0,079	0,061	0,067	0,079	0,085	0,091	0,102	0,117	0,132	0,131
3,5	0,044	0,048	0,034	0,046	0,050	0,058	0,069	0,080	0,105	0,121	0,114
3,7	0,039	0,047	0,035	0,037	0,048	0,060	0,074	0,082	0,081	0,081	0,100
3,9	0,045	0,038	0,033	0,040	0,046	0,060	0,071	0,081	0,109	0,136	0,144
4,1	0,033	0,031	0,027	0,029	0,036	0,038	0,038	0,044	0,066	0,099	0,138
4,3	0,033	0,029	0,032	0,036	0,042	0,049	0,057	0,063	0,074	0,087	0,101
4,5	0,050	0,047	0,046	0,052	0,056	0,061	0,067	0,072	0,083	0,100	0,132
4,7	0,053	0,050	0,044	0,050	0,057	0,059	0,056	0,055	0,058	0,066	0,083
4,9	0,050	0,049	0,049	0,047	0,054	0,053	0,055	0,059	0,062	0,071	0,091
5,1	0,037	0,038	0,040	0,041	0,041	0,048	0,050	0,053	0,057	0,065	0,078
5,3	0,032	0,029	0,028	0,035	0,035	0,036	0,038	0,042	0,046	0,051	0,057
5,5	0,026	0,030	0,029	0,025	0,031	0,036	0,038	0,038	0,037	0,035	0,041
5,7	0,035	0,035	0,033	0,033	0,038	0,041	0,044	0,047	0,049	0,050	0,052
5,9	0,034	0,029	0,023	0,025	0,028	0,048	0,058	0,064	0,073	0,080	0,084
6,1	0,019	0,025	0,029	0,037	0,041	0,027	0,030	0,031	0,037	0,042	0,045
6,3	0,020	0,020	0,018	0,019	0,021	0,023	0,027	0,032	0,036	0,042	0,048
6,5	0,018	0,018	0,019	0,020	0,022	0,023	0,023	0,022	0,025	0,026	0,030
6,7	0,020	0,020	0,021	0,023	0,023	0,025	0,027	0,030	0,032	0,037	0,043
6,9	0,024	0,024	0,025	0,024	0,026	0,026	0,027	0,029	0,029	0,032	0,035
7,1	0,025	0,025	0,025	0,026	0,027	0,027	0,029	0,030	0,031	0,032	0,032
7,3	0,016	0,016	0,017	0,017	0,017	0,017	0,018	0,019	0,019	0,021	0,023
7,5	0,019	0,020	0,020	0,020	0,020	0,021	0,022	0,022	0,023	0,024	0,024
7,7	0,014	0,015	0,015	0,015	0,015	0,016	0,016	0,017	0,018	0,019	0,019
7,9	0,013	0,013	0,013	0,014	0,014	0,014	0,014	0,015	0,016	0,016	0,016
8,1	0,012	0,012	0,012	0,012	0,012	0,013	0,014	0,015	0,016	0,016	0,017
8,3	0,011	0,012	0,012	0,012	0,013	0,013	0,013	0,013	0,014	0,015	0,017
8,5	0,012	0,011	0,011	0,012	0,012	0,013	0,013	0,013	0,014	0,014	0,014
8,7	0,011	0,012	0,012	0,012	0,013	0,013	0,013	0,013	0,013	0,014	0,015
8,9	0,011	0,010	0,010	0,011	0,012	0,012	0,012	0,013	0,013	0,014	0,015

**Note:**

The normalization current is 34,8 A.



BUREAU  
VERITAS

Report No.: PVIR200511N080-2

The tests had been performed on the SOFAR 24KTLX-G3 and SOFAR 15KTLX-G3 are valid for the SOFAR 17KTLX-G3, SOFAR 20KTLX-G3 and SOFAR 22KTLX-G3, since it is identical in hardware and software construction except output power derated by software.

Test result: SOFAR 24KTLX-G3											
Harmonics											
P/P <sub>n</sub> [%]	0	10	20	30	40	50	60	70	80	90	100
Order	I [%]	I [%]	I [%]	I [%]	I [%]	I [%]	I [%]	I [%]	I [%]	I [%]	I [%]
1	3,061	10,126	20,255	30,427	40,524	50,632	60,703	70,768	80,806	90,809	100,790
2	0,140	0,091	0,097	0,089	0,092	0,098	0,093	0,100	0,101	0,105	0,108
3	0,288	0,299	0,316	0,317	0,330	0,338	0,342	0,354	0,360	0,385	0,406
4	0,118	0,074	0,068	0,062	0,061	0,060	0,062	0,062	0,061	0,062	0,067
5	0,777	0,665	0,586	0,594	0,567	0,553	0,553	0,537	0,537	0,522	0,570
6	0,059	0,033	0,033	0,039	0,034	0,055	0,042	0,040	0,040	0,038	0,038
7	0,381	0,383	0,349	0,372	0,398	0,390	0,395	0,404	0,415	0,432	0,476
8	0,150	0,031	0,032	0,059	0,039	0,040	0,034	0,032	0,032	0,033	0,035
9	0,090	0,113	0,095	0,093	0,099	0,101	0,107	0,113	0,116	0,126	0,116
10	0,122	0,032	0,029	0,027	0,028	0,028	0,031	0,028	0,029	0,029	0,035
11	0,299	0,226	0,171	0,163	0,170	0,189	0,207	0,231	0,244	0,270	0,287
12	0,073	0,029	0,024	0,028	0,027	0,028	0,028	0,028	0,029	0,032	0,031
13	0,258	0,123	0,086	0,107	0,116	0,135	0,141	0,154	0,158	0,157	0,189
14	0,135	0,028	0,029	0,027	0,027	0,028	0,031	0,029	0,030	0,029	0,034
15	0,062	0,040	0,044	0,046	0,066	0,070	0,062	0,073	0,058	0,053	0,086
16	0,123	0,030	0,029	0,027	0,026	0,028	0,031	0,029	0,029	0,030	0,032
17	0,231	0,137	0,135	0,119	0,168	0,164	0,147	0,148	0,130	0,161	0,174
18	0,081	0,028	0,023	0,023	0,024	0,025	0,025	0,025	0,027	0,027	0,027
19	0,243	0,146	0,128	0,076	0,102	0,102	0,086	0,081	0,072	0,068	0,083
20	0,109	0,029	0,027	0,025	0,024	0,025	0,028	0,028	0,029	0,027	0,029
21	0,049	0,036	0,034	0,034	0,037	0,039	0,041	0,045	0,056	0,054	0,044
22	0,117	0,037	0,027	0,023	0,023	0,024	0,024	0,025	0,024	0,052	0,030
23	0,180	0,251	0,093	0,155	0,107	0,147	0,147	0,137	0,111	0,083	0,081
24	0,076	0,029	0,027	0,024	0,025	0,027	0,042	0,028	0,030	0,031	0,033
25	0,185	0,206	0,049	0,099	0,042	0,065	0,068	0,062	0,071	0,090	0,108
26	0,155	0,028	0,025	0,025	0,022	0,024	0,026	0,025	0,029	0,027	0,031
27	0,043	0,029	0,032	0,037	0,031	0,034	0,036	0,038	0,057	0,053	0,040
28	0,103	0,035	0,025	0,019	0,019	0,020	0,022	0,023	0,024	0,028	0,027
29	0,141	0,240	0,065	0,082	0,110	0,079	0,104	0,119	0,109	0,095	0,130
30	0,069	0,026	0,019	0,017	0,017	0,021	0,022	0,022	0,024	0,026	0,028
31	0,134	0,198	0,129	0,141	0,073	0,096	0,091	0,072	0,081	0,110	0,148
32	0,147	0,028	0,022	0,022	0,019	0,022	0,024	0,024	0,025	0,027	0,030
33	0,037	0,024	0,025	0,022	0,023	0,026	0,030	0,027	0,036	0,032	0,040
34	0,091	0,040	0,023	0,017	0,015	0,017	0,019	0,023	0,028	0,026	0,034
35	0,102	0,078	0,099	0,060	0,048	0,072	0,044	0,070	0,092	0,100	0,138
36	0,059	0,022	0,016	0,017	0,030	0,040	0,019	0,020	0,021	0,023	0,026
37	0,093	0,218	0,106	0,124	0,129	0,115	0,133	0,110	0,102	0,121	0,140
38	0,098	0,024	0,021	0,017	0,016	0,018	0,020	0,021	0,022	0,027	0,024
39	0,035	0,039	0,028	0,027	0,027	0,028	0,031	0,029	0,042	0,030	0,044
40	0,063	0,037	0,023	0,018	0,019	0,021	0,025	0,025	0,027	0,032	0,035
41	0,080	0,076	0,096	0,068	0,075	0,048	0,056	0,043	0,069	0,090	0,126
42	0,047	0,022	0,016	0,016	0,016	0,017	0,019	0,021	0,029	0,025	0,025
43	0,069	0,140	0,102	0,154	0,150	0,123	0,135	0,129	0,116	0,111	0,108



44	0,052	0,031	0,015	0,016	0,025	0,020	0,020	0,019	0,019	0,031	0,034
45	0,030	0,045	0,038	0,045	0,030	0,034	0,044	0,078	0,067	0,044	0,031
46	0,040	0,025	0,024	0,014	0,013	0,016	0,018	0,021	0,021	0,028	0,028
47	0,071	0,069	0,094	0,141	0,111	0,080	0,058	0,047	0,044	0,071	0,106
48	0,035	0,017	0,015	0,016	0,014	0,015	0,017	0,018	0,022	0,022	0,023
49	0,047	0,055	0,042	0,113	0,117	0,117	0,108	0,109	0,101	0,085	0,067
50	0,052	0,037	0,017	0,013	0,013	0,016	0,016	0,018	0,021	0,019	0,022

**Interharmonics**

P/P <sub>n</sub> [%]	0	10	20	30	40	50	60	70	80	90	100
f [Hz]	I [%]	I [%]	I [%]	I [%]	I [%]	I [%]	I [%]	I [%]	I [%]	I [%]	I [%]
75	0,119	0,097	0,098	0,120	0,174	0,207	0,244	0,290	0,330	0,353	0,400
125	0,051	0,044	0,041	0,045	0,066	0,073	0,081	0,101	0,112	0,110	0,123
175	0,058	0,045	0,044	0,046	0,061	0,062	0,066	0,077	0,095	0,091	0,096
225	0,135	0,076	0,047	0,049	0,076	0,065	0,078	0,091	0,084	0,089	0,105
275	0,148	0,081	0,051	0,057	0,053	0,065	0,058	0,060	0,080	0,068	0,071
325	0,121	0,066	0,058	0,054	0,085	0,059	0,070	0,070	0,067	0,076	0,072
375	0,137	0,062	0,060	0,089	0,093	0,065	0,061	0,062	0,075	0,070	0,061
425	0,068	0,057	0,122	0,065	0,054	0,055	0,057	0,057	0,062	0,061	0,080
475	0,073	0,046	0,062	0,055	0,059	0,056	0,056	0,055	0,062	0,078	0,066
525	0,141	0,068	0,049	0,056	0,060	0,060	0,062	0,060	0,064	0,070	0,074
575	0,156	0,071	0,051	0,056	0,058	0,062	0,064	0,062	0,070	0,072	0,080
625	0,136	0,066	0,055	0,074	0,078	0,072	0,063	0,076	0,078	0,134	0,094
675	0,151	0,082	0,079	0,078	0,057	0,075	0,095	0,072	0,110	0,064	0,086
725	0,073	0,050	0,054	0,074	0,077	0,066	0,059	0,073	0,075	0,135	0,096
775	0,077	0,072	0,078	0,079	0,051	0,066	0,089	0,063	0,105	0,057	0,075
825	0,111	0,074	0,063	0,089	0,092	0,077	0,067	0,085	0,088	0,182	0,119
875	0,132	0,101	0,100	0,095	0,052	0,077	0,115	0,075	0,137	0,057	0,077
925	0,114	0,073	0,049	0,059	0,063	0,056	0,057	0,064	0,066	0,106	0,080
975	0,133	0,083	0,066	0,064	0,048	0,059	0,075	0,061	0,089	0,056	0,062
1025	0,082	0,043	0,041	0,044	0,044	0,045	0,047	0,048	0,052	0,053	0,056
1075	0,059	0,063	0,040	0,043	0,042	0,044	0,046	0,048	0,054	0,066	0,098
1125	0,085	0,060	0,053	0,041	0,042	0,047	0,049	0,061	0,063	0,063	0,057
1175	0,090	0,063	0,062	0,041	0,042	0,045	0,067	0,064	0,070	0,059	0,063
1225	0,086	0,071	0,044	0,044	0,051	0,072	0,050	0,051	0,055	0,061	0,060
1275	0,105	0,064	0,037	0,061	0,041	0,041	0,045	0,049	0,056	0,057	0,060
1325	0,059	0,045	0,041	0,036	0,037	0,040	0,044	0,044	0,051	0,051	0,057
1375	0,047	0,037	0,033	0,034	0,034	0,037	0,040	0,042	0,048	0,054	0,059
1425	0,067	0,050	0,035	0,034	0,033	0,038	0,040	0,045	0,051	0,056	0,055
1475	0,067	0,053	0,032	0,032	0,031	0,035	0,039	0,044	0,051	0,055	0,059
1525	0,063	0,059	0,033	0,032	0,033	0,038	0,040	0,045	0,048	0,055	0,056
1575	0,077	0,052	0,030	0,030	0,029	0,034	0,037	0,040	0,046	0,049	0,056
1625	0,050	0,032	0,029	0,029	0,029	0,034	0,037	0,038	0,042	0,045	0,056
1675	0,041	0,030	0,027	0,028	0,026	0,030	0,034	0,036	0,041	0,046	0,062
1725	0,054	0,041	0,031	0,028	0,028	0,031	0,035	0,036	0,042	0,049	0,062
1775	0,048	0,040	0,030	0,047	0,047	0,031	0,032	0,037	0,042	0,047	0,053
1825	0,047	0,044	0,035	0,025	0,031	0,044	0,061	0,040	0,041	0,047	0,050
1875	0,052	0,040	0,045	0,023	0,025	0,027	0,031	0,068	0,080	0,043	0,048
1925	0,039	0,039	0,025	0,024	0,024	0,028	0,032	0,032	0,035	0,093	0,106

1975	0,048	0,026	0,022	0,024	0,022	0,025	0,041	0,045	0,052	0,039	0,045
<b>Higher Frequencies</b>											
P/P <sub>n</sub> [%]	0	10	20	30	40	50	60	70	80	90	100
f [kHz]	I [%]	I [%]	I [%]	I [%]	I [%]	I [%]	I [%]	I [%]	I [%]	I [%]	I [%]
2,1	0,138	0,176	0,149	0,176	0,177	0,144	0,160	0,153	0,158	0,172	0,185
2,3	0,119	0,109	0,129	0,168	0,148	0,138	0,140	0,132	0,147	0,172	0,194
2,5	0,103	0,094	0,079	0,131	0,130	0,132	0,129	0,130	0,123	0,114	0,105
2,7	0,125	0,108	0,141	0,177	0,180	0,167	0,120	0,118	0,112	0,108	0,123
2,9	0,102	0,088	0,093	0,079	0,111	0,142	0,145	0,121	0,111	0,101	0,109
3,1	0,122	0,133	0,135	0,154	0,168	0,155	0,161	0,153	0,153	0,190	0,223
3,3	0,074	0,116	0,095	0,089	0,096	0,106	0,122	0,136	0,142	0,144	0,150
3,5	0,074	0,079	0,072	0,055	0,061	0,071	0,075	0,086	0,092	0,106	0,108
3,7	0,064	0,076	0,069	0,059	0,056	0,064	0,076	0,084	0,095	0,116	0,125
3,9	0,065	0,075	0,065	0,053	0,054	0,063	0,070	0,083	0,094	0,111	0,115
4,1	0,057	0,061	0,059	0,039	0,043	0,048	0,052	0,054	0,058	0,059	0,062
4,3	0,059	0,054	0,043	0,054	0,049	0,058	0,065	0,072	0,081	0,090	0,097
4,5	0,075	0,075	0,073	0,079	0,083	0,091	0,096	0,101	0,104	0,109	0,115
4,7	0,083	0,086	0,076	0,069	0,071	0,077	0,083	0,087	0,090	0,088	0,086
4,9	0,083	0,080	0,078	0,079	0,075	0,077	0,084	0,089	0,093	0,093	0,097
5,1	0,053	0,061	0,059	0,060	0,059	0,062	0,065	0,068	0,067	0,070	0,069
5,3	0,048	0,050	0,044	0,045	0,048	0,053	0,054	0,056	0,061	0,061	0,061
5,5	0,043	0,046	0,053	0,049	0,042	0,040	0,047	0,053	0,056	0,061	0,061
5,7	0,054	0,055	0,059	0,052	0,052	0,055	0,058	0,063	0,065	0,069	0,069
5,9	0,042	0,041	0,041	0,039	0,037	0,040	0,042	0,045	0,046	0,048	0,050
6,1	0,046	0,045	0,044	0,045	0,054	0,057	0,063	0,067	0,072	0,079	0,088
6,3	0,027	0,030	0,028	0,028	0,028	0,030	0,033	0,036	0,037	0,039	0,041
6,5	0,031	0,031	0,030	0,028	0,029	0,030	0,031	0,032	0,033	0,035	0,040
6,7	0,031	0,031	0,032	0,035	0,036	0,036	0,039	0,040	0,042	0,043	0,045
6,9	0,038	0,038	0,038	0,039	0,038	0,039	0,040	0,041	0,042	0,043	0,044
7,1	0,038	0,039	0,041	0,040	0,040	0,042	0,042	0,043	0,044	0,044	0,045
7,3	0,024	0,026	0,026	0,028	0,026	0,026	0,027	0,028	0,028	0,029	0,029
7,5	0,031	0,031	0,032	0,033	0,032	0,032	0,032	0,033	0,034	0,033	0,036
7,7	0,023	0,023	0,023	0,024	0,023	0,024	0,024	0,025	0,026	0,026	0,027
7,9	0,021	0,021	0,021	0,021	0,022	0,022	0,023	0,023	0,024	0,024	0,025
8,1	0,018	0,019	0,019	0,019	0,018	0,019	0,020	0,020	0,021	0,021	0,021
8,3	0,018	0,019	0,018	0,019	0,019	0,019	0,020	0,021	0,020	0,021	0,021
8,5	0,019	0,019	0,018	0,018	0,018	0,019	0,020	0,020	0,021	0,021	0,021
8,7	0,018	0,018	0,018	0,019	0,019	0,020	0,020	0,020	0,021	0,020	0,021
8,9	0,017	0,016	0,016	0,017	0,017	0,018	0,018	0,019	0,019	0,019	0,019

**Note:**

The normalization current is 21,7 A.

The tests had been performed on the SOFAR 24KTLX-G3 and SOFAR 15KTLX-G3 are valid for the SOFAR 17KTLX-G3, SOFAR 20KTLX-G3 and SOFAR 22KTLX-G3, since it is identical in hardware and software construction except output power derated by software.

4.8 EMC and power quality Switching operation (Refer IEC 61400-21)		P			
<b>Test result:</b>					
Max. number of switching operations, $N_{10}$	10				
Max. number of switching operations, $N_{120}$	120				
Case of switching operation		Cut-in at 9% $P_{E_{max}}$			
Grid impedance angle, $\psi_k$	30°	50°	70°	85°	
Flicker step factor, $k_f(\psi_k)$	0,06	0,09	0,12	0,14	
Voltage change factor, $k_u(\psi_k)$	0,37	0,31	0,21	0,19	
Maximum inrush current factor $k_{imax}$	0,06				
Case of switching operation		Cut-in at 100% $P_{E_{max}}$			
Grid impedance angle, $\psi_k$	30°	50°	70°	85°	
Flicker step factor, $k_f(\psi_k)$	0,53	0,87	1,25	1,43	
Voltage change factor, $k_u(\psi_k)$	2,98	2,87	2,47	1,98	
Maximum inrush current factor $k_{imax}$	0,06				
Case of switching operation		Service disconnection at rated power			
Grid impedance angle, $\psi_k$	30°	50°	70°	85°	
Flicker step factor, $k_f(\psi_k)$	1,11	0,89	0,57	0,31	
Voltage change factor, $k_u(\psi_k)$	2,78	2,16	1,31	0,60	
Maximum inrush current factor $k_{imax}$	0,02				
Worst case over all switching operations, $k_{imax}$	0,06				
<b>Note:</b>					
<p><math>S_{k,fi}/S_n</math> in the fictitious grid was set to:20.</p> <p>The tests had been performed on the SOFAR 24KTLX-G3 is valid for the SOFAR 15KTLX-G3, SOFAR 17KTLX-G3, SOFAR 20KTLX-G3 and SOFAR 22KTLX-G3, since it is identical in hardware and software construction except output power derated by software.</p>					

<b>4.8</b>	<b>Voltage fluctuation and flicker</b>	<b>P</b>
------------	--	----------

**Test result:**

<b>Test conditions:</b>	Maximum permissible voltage fluctuation (expressed as a percentage of nominal voltage at 100 % power) and flicker as per EN 61000-3-3 and/or EN 61000-3-11.
-------------------------	---

**Test:**

<b>Value</b>	<b>P<sub>st</sub></b>	<b>P<sub>lt</sub> 2 hours</b>	<b>d(t)<sub>500ms</sub></b>	<b>d<sub>c</sub></b>	<b>d<sub>max</sub></b>
<b>Limit</b>	1,0	0,65	3,3%	3,3%	4%

<b>Test value</b>	See below
-------------------	-----------

**SOFAR 15KTLX-G3**

	dc[%]	dmax[%]	d(t)[ms]	Pst	Plt
Limit	3.30	4.00	500 3.30%	1.00	0.65 N:12
No. 1	0.087 Pass	0.188 Pass	0.0 Pass	0.041 Pass	
2	0.085 Pass	0.159 Pass	0.0 Pass	0.039 Pass	
3	0.110 Pass	0.159 Pass	0.0 Pass	0.048 Pass	
4	0.113 Pass	0.161 Pass	0.0 Pass	0.054 Pass	
5	0.113 Pass	0.153 Pass	0.0 Pass	0.053 Pass	
6	0.115 Pass	0.136 Pass	0.0 Pass	0.058 Pass	
7	0.106 Pass	0.162 Pass	0.0 Pass	0.061 Pass	
8	0.103 Pass	0.137 Pass	0.0 Pass	0.057 Pass	
9	0.104 Pass	0.156 Pass	0.0 Pass	0.056 Pass	
10	0.097 Pass	0.134 Pass	0.0 Pass	0.054 Pass	
11	0.103 Pass	0.162 Pass	0.0 Pass	0.054 Pass	
12	0.099 Pass	0.154 Pass	0.0 Pass	0.057 Pass	
<b>Result</b>	<b>Pass</b>	<b>Pass</b>	<b>Pass</b>	<b>Pass</b>	0.053 <b>Pass</b>

	dc[%]	dmax[%]	d(t)[ms]	Pst	Plt
Limit	3.30	4.00	500 3.30%	1.00	0.65 N:12
No. 1	0.004 Pass	0.111 Pass	0.0 Pass	0.142 Pass	
2	0.003 Pass	0.119 Pass	0.0 Pass	0.141 Pass	
3	0.011 Pass	0.101 Pass	0.0 Pass	0.140 Pass	
4	0.012 Pass	0.111 Pass	0.0 Pass	0.140 Pass	
5	0.000 Pass	0.000 Pass	0.0 Pass	0.140 Pass	
6	0.000 Pass	0.000 Pass	0.0 Pass	0.140 Pass	
7	0.000 Pass	0.000 Pass	0.0 Pass	0.139 Pass	
8	0.018 Pass	0.158 Pass	0.0 Pass	0.140 Pass	
9	0.014 Pass	0.123 Pass	0.0 Pass	0.139 Pass	
10	0.009 Pass	0.107 Pass	0.0 Pass	0.140 Pass	
11	0.006 Pass	0.102 Pass	0.0 Pass	0.139 Pass	
12	0.009 Pass	0.117 Pass	0.0 Pass	0.140 Pass	
<b>Result</b>	<b>Pass</b>	<b>Pass</b>	<b>Pass</b>	<b>Pass</b>	0.140 <b>Pass</b>

	dc[%]	dmax[%]	d(t)[ms]	Pst	Plt
Limit	3.30	4.00	500 3.30%	1.00	0.65 N:12
No. 1	0.000 Pass	0.000 Pass	0.0 Pass	0.053 Pass	
2	0.000 Pass	0.000 Pass	0.0 Pass	0.051 Pass	
3	0.000 Pass	0.000 Pass	0.0 Pass	0.049 Pass	
4	0.000 Pass	0.000 Pass	0.0 Pass	0.050 Pass	
5	0.017 Pass	0.108 Pass	0.0 Pass	0.050 Pass	
6	0.020 Pass	0.106 Pass	0.0 Pass	0.049 Pass	
7	0.014 Pass	0.104 Pass	0.0 Pass	0.050 Pass	
8	0.057 Pass	0.109 Pass	0.0 Pass	0.050 Pass	
9	0.049 Pass	0.108 Pass	0.0 Pass	0.049 Pass	
10	0.002 Pass	0.106 Pass	0.0 Pass	0.048 Pass	
11	0.000 Pass	0.000 Pass	0.0 Pass	0.049 Pass	
12	0.000 Pass	0.000 Pass	0.0 Pass	0.049 Pass	
<b>Result</b>	<b>Pass</b>	<b>Pass</b>	<b>Pass</b>	<b>Pass</b>	0.050 <b>Pass</b>

**SOFAR 24KTLX-G3**

	dc[%]	dmax[%]	d(t)[ms]	Pst	Plt
Limit	3.30	4.00	500 3.30%	1.00	0.65 N:12
No. 1	0.114 Pass	0.159 Pass	0.0 Pass	0.044 Pass	
2	0.068 Pass	0.109 Pass	0.0 Pass	0.037 Pass	
3	0.092 Pass	0.132 Pass	0.0 Pass	0.027 Pass	
4	0.017 Pass	0.165 Pass	0.0 Pass	0.033 Pass	
5	0.098 Pass	0.213 Pass	0.0 Pass	0.025 Pass	
6	0.071 Pass	0.133 Pass	0.0 Pass	0.025 Pass	
7	0.078 Pass	0.171 Pass	0.0 Pass	0.026 Pass	
8	0.104 Pass	0.199 Pass	0.0 Pass	0.032 Pass	
9	0.036 Pass	0.151 Pass	0.0 Pass	0.027 Pass	
10	0.095 Pass	0.152 Pass	0.0 Pass	0.028 Pass	
11	0.081 Pass	0.146 Pass	0.0 Pass	0.030 Pass	
12	0.090 Pass	0.144 Pass	0.0 Pass	0.033 Pass	
Result	Pass	Pass	Pass	Pass	0.032 Pass

	dc[%]	dmax[%]	d(t)[ms]	Pst	Plt
Limit	3.30	4.00	500 3.30%	1.00	0.65 N:12
No. 1	0.010 Pass	0.119 Pass	0.0 Pass	0.139 Pass	
2	0.007 Pass	0.111 Pass	0.0 Pass	0.138 Pass	
3	0.006 Pass	0.114 Pass	0.0 Pass	0.137 Pass	
4	0.000 Pass	0.000 Pass	0.0 Pass	0.136 Pass	
5	0.007 Pass	0.104 Pass	0.0 Pass	0.136 Pass	
6	0.009 Pass	0.103 Pass	0.0 Pass	0.137 Pass	
7	0.000 Pass	0.000 Pass	0.0 Pass	0.136 Pass	
8	0.006 Pass	0.105 Pass	0.0 Pass	0.137 Pass	
9	0.000 Pass	0.000 Pass	0.0 Pass	0.137 Pass	
10	0.011 Pass	0.104 Pass	0.0 Pass	0.136 Pass	
11	0.010 Pass	0.119 Pass	0.0 Pass	0.137 Pass	
12	0.000 Pass	0.000 Pass	0.0 Pass	0.137 Pass	
Result	Pass	Pass	Pass	Pass	0.137 Pass

	dc[%]	dmax[%]	d(t)[ms]	Pst	Plt
Limit	3.30	4.00	500 3.30%	1.00	0.65 N:12
No. 1	0.000 Pass	0.000 Pass	0.0 Pass	0.048 Pass	
2	0.000 Pass	0.000 Pass	0.0 Pass	0.047 Pass	
3	0.013 Pass	0.101 Pass	0.0 Pass	0.046 Pass	
4	0.009 Pass	0.101 Pass	0.0 Pass	0.045 Pass	
5	0.000 Pass	0.000 Pass	0.0 Pass	0.046 Pass	
6	0.000 Pass	0.000 Pass	0.0 Pass	0.046 Pass	
7	0.000 Pass	0.000 Pass	0.0 Pass	0.046 Pass	
8	0.000 Pass	0.000 Pass	0.0 Pass	0.046 Pass	
9	0.000 Pass	0.000 Pass	0.0 Pass	0.046 Pass	
10	0.020 Pass	0.108 Pass	0.0 Pass	0.046 Pass	
11	0.000 Pass	0.000 Pass	0.0 Pass	0.047 Pass	
12	0.000 Pass	0.000 Pass	0.0 Pass	0.047 Pass	
Result	Pass	Pass	Pass	Pass	0.046 Pass

**Note:**

\*The stationary deviance of dc% is more relevant than the dynamic deviance of dmax at starting and stopping, Mains Impedance according EN61000-3-11:

**R<sub>max</sub> = 0,24Ω; jX<sub>max</sub> = 0,15Ω @50Hz (|Z<sub>max</sub>| = 0,283/0,4717Ω) for single phase inverter use also  
R<sub>n</sub> = 0,16Ω; jX<sub>n</sub> = 0,1Ω.**

Calculation of the maximum permissible grid impedance at the point of common coupling based on dc:

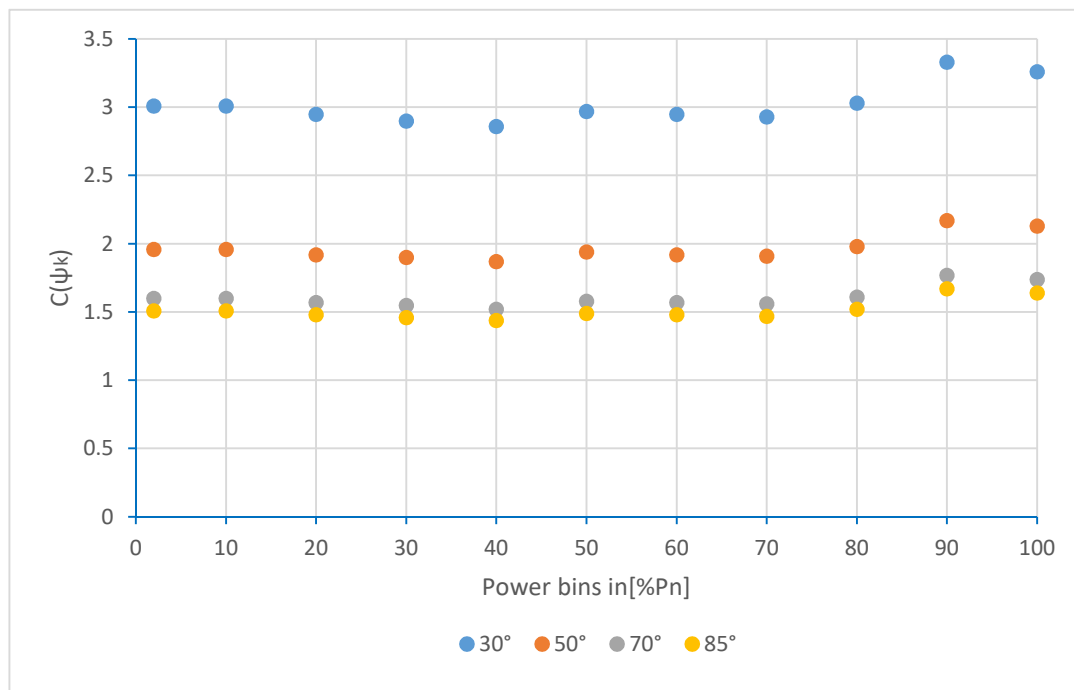
**Z<sub>max</sub> = Z<sub>ref</sub> \* 3,3% / d<sub>c</sub>(P<sub>n</sub>).**

The tests should be based on the limits of the EN 61000-3-3 for less than 16A and on EN 61000-3-11 for more than 16A.

The test results refer to the original test report PV200511N080-2 issued by Bureau Veritas Shenzhen Co., Ltd. Dongguan Branch, dated on 2020-10-21.

4.8 EMC and power quality Flicker and voltage fluctuations											P
Method: Measurement and evaluation was carried out according to the procedure in IEC 61400-21.											
<b>Test result:</b>											
Grid impedance angle, $\psi_k$	30°			50°			70°			85°	
Operating point, $P_a/P_{E_{max}}$ [%]	Flicker coefficient, $c(\psi_k)$										
2	3,01			1,96			1,60			1,51	
10	3,01			1,96			1,60			1,51	
20	2,95			1,92			1,57			1,48	
30	2,90			1,90			1,55			1,46	
40	2,86			1,87			1,52			1,44	
50	2,97			1,94			1,58			1,49	
60	2,95			1,92			1,57			1,48	
70	2,93			1,91			1,56			1,47	
80	3,03			1,98			1,61			1,52	
90	3,33			2,17			1,77			1,67	
100	3,26			2,13			1,74			1,64	
Max. Flicker coefficient, $c(\psi_k)$	3,26			2,13			1,74			1,64	
Max. Short-term flicker, Pst	0,163			0,107			0,087			0,082	
Reactive power setpoint during testing [kVar]											0
P [% $P_{E_{max}}$ ]	2	10	20	30	40	50	60	70	80	90	100
Number of data sets	1	1	1	1	1	1	1	1	1	1	1
<b>Note:</b> The table entries are worst case values. $S_{k, fic}/S_n$ in the fictitious grid was set to:20. The tests had been performed on the SOFAR 24KTLX-G3 is valid for the SOFAR 15KTLX-G3, SOFAR 17KTLX-G3, SOFAR 20KTLX-G3 and SOFAR 22KTLX-G3, since it is identical in hardware and software construction except output power derated by software.											

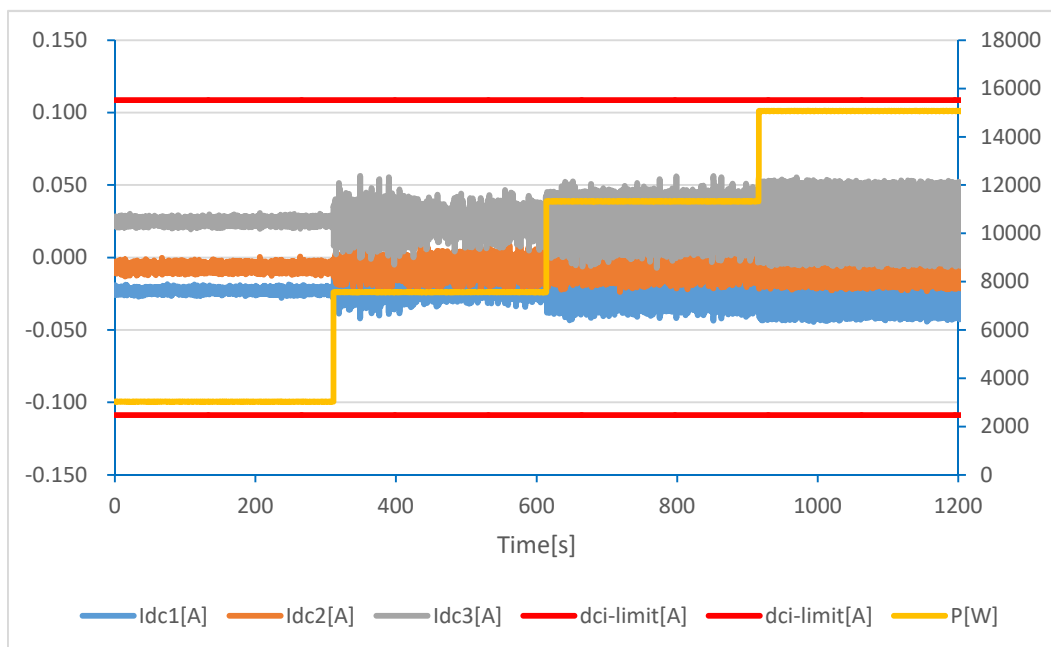
**Maximum Flicker coefficients  $c(\psi_k)$  vs. power bins**



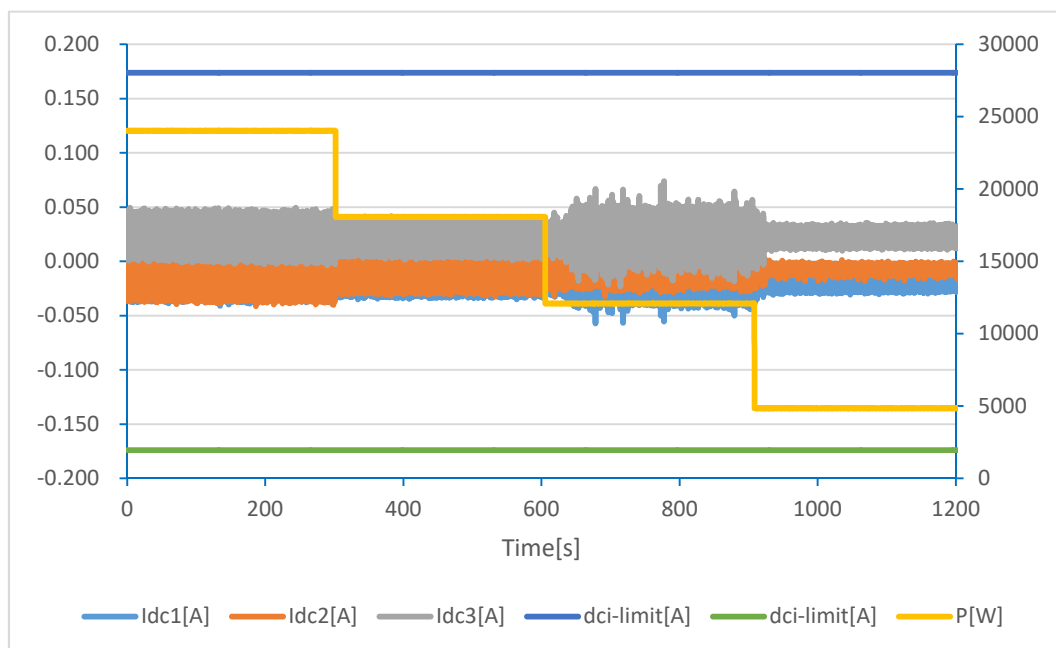
<b>4.8 EMC and power quality DC-Injection</b>		<b>P</b>		
<b>Test result: SOFAR 15KTLX-G3</b>				
<b>Protection limit</b>	<b>Tested at four power levels limit 0,5% of I<sub>AC,nom</sub> (43mA)</b>			
<b>Output power</b>	~20%	~50%	75%	~100%
<b>Max. test value [mA]</b>	31	56	56	55
<b>Ave. test value [mA]</b>	18	18	18	19
<b>Test result: SOFAR 24KTLX-G3</b>				
<b>Protection limit</b>	<b>Tested at four power levels limit 0,5% of I<sub>AC,nom</sub> (109mA)</b>			
<b>Output power</b>	~20%	~50%	75%	~100%
<b>Max. test value [mA]</b>	46	74	41	49
<b>Ave. test value [mA]</b>	17	19	19	21
<b>Note:</b> The tests had been performed on the SOFAR 24KTLX-G3 is valid for the SOFAR 15KTLX-G3, SOFAR 17KTLX-G3, SOFAR 20KTLX-G3 and SOFAR 22KTLX-G3, since it is identical in hardware and software construction except output power derated by software.				



**Diagram of permanent dc-injection of SOFAR 15KTLX-G3**

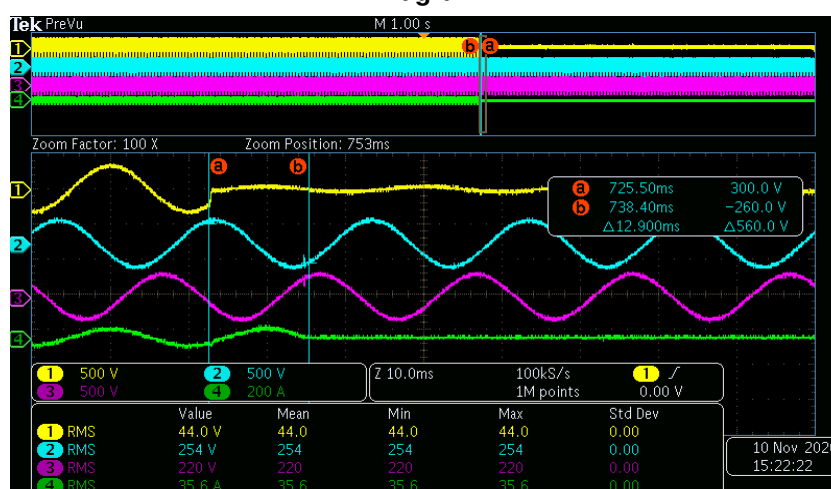


**Diagram of permanent dc-injection of SOFAR 24KTLX-G3**



4.8 Immunity to voltage dips and short interruptions					P
For a directly coupled SSEG			For a Inverter SSEG		
Parameter	Symbol	Value	Time after fault	Volts	Amps
Peak Short Circuit current	$I_p$	N/A	20ms	42,4	28,8
Initial Value of aperiodic current	A	N/A	100ms	37,1	13,7
Initial symmetrical short-circuit current*	$I_k$	N/A	250ms	N/A	N/A
Decaying (aperiodic) component of short circuit current*	$i_{DC}$	N/A	500ms	N/A	N/A
Reactance/Resistance Ratio of source*	X/R	N/A	Time to trip	12,9ms	In seconds

Diagram



**Note:**

For rotating machines and linear piston machines the test should produce a 0s – 2s plot of the short circuit current as seen at the Generating Unit terminals.

\* Values for these parameters should be provided where the short circuit duration is sufficiently long to enable interpolation of the plot.

The tests had been performed on the SOFAR 24KTLX-G3 is valid for the SOFAR 15KTLX-G3, SOFAR 17KTLX-G3, SOFAR 20KTLX-G3 and SOFAR 22KTLX-G3, since it is identical in hardware and software construction except output power derated by software.

### EN 50549-1:2019: Interface protection

Clause	Test requirement	Test procedure according standard	Result
4.9.3	Requirements on voltage and frequency protection	CEI 0-21:2019-04, Annex A.3.1 to A.3.4	<b>P</b>
4.9.3.1	Undervoltage protection	EN 50438, Annex D.2.3	<b>P</b>
	Overvoltage protection	EN 50438, Annex D.2.3	<b>P</b>
	Overvoltage 10 min mean protection	EN 50160	<b>P</b>
	Underfrequency protection	EN 50438, Annex D.2.4	<b>P</b>
	Overfrequency protection	EN 50438, Annex D.2.4	<b>P</b>
4.9.4.2	Loss of Mains (LoM) detection	IEC 62116:2014	<b>P</b>

<b>4.9.3 Requirements on voltage and frequency protection Checklist</b>						<b>P</b>
<b>Several points to check</b>						
Clause 4.9.3.1 to 4.9.3.6	All thresholds must be adjustable					<b>P</b>
<b>Voltage values</b>						
Threshold	Stage 1 [27 <]			Stage 2 [27 <<]		
	Operate voltage		Operate time	Operate voltage		Operate time
Range	0,2-1,0 U <sub>n</sub>		0,1-100s	0,2-1,0 U <sub>n</sub>		0,1-5s
Steps	0,01 U <sub>n</sub>		0,1 s	0,01 U <sub>n</sub>		0,05s
Threshold	Stage 1 [59 >]		Stage 2 [59 >>]		Overvoltage 10 min mean protection	
	Operate voltage	Operate time	Operate voltage	Operate time	Operate voltage	Operate time
Range	1,0-1,2 U <sub>n</sub>	0,1-100s	1,0-1,3 U <sub>n</sub>	0,1-5s	1,0-1,15 U <sub>n</sub>	3s not adjustable
Steps	0,01 U <sub>n</sub>	0,1s	0,01 U <sub>n</sub>	0,05s	0,01 U <sub>n</sub>	--
<b>Frequency values</b>						
Threshold	Stage 1 [81 <]			Stage 2 [81 <<]		
	Operate frequency		Operate time	Operate frequency		Operate time
Range	47,0-50,0Hz		0,1-100s	47,0-50,0Hz		0,1-5s
Steps	0,1 Hz		0,1 s	0,1 Hz		0,05s
Threshold	Stage 1 [81 >]			Stage 2 [81 >>]		
	Operate frequency		Operate time	Operate frequency		Operate time
Range	50,0-52,0Hz		0,1-100s	50,0-52,0Hz		0,1-5s
Steps	0,1 Hz		0,1 s	0,1 Hz		0,05s
4.9.2.6	Insensitive against 40ms frequency transients, so that the unit will not trip					<b>P</b>
<b>Note:</b> The tests had been performed on the SOFAR 24KTLX-G3 is valid for the SOFAR 15KTLX-G3, SOFAR 17KTLX-G3, SOFAR 20KTLX-G3 and SOFAR 22KTLX-G3, since it is identical in hardware and software construction except output power derated by software.						

4.9.3 Requirements on voltage and frequency protection			P		
4.9.3.1 General (Interface protection: Over/under voltage) (Setting value refer EN 50438 for default settings)					
Test conditions			Output power: 10,0kW Frequency: 50+/-0,2Hz		
Phase	Limit [V]	Trip value [V]	Voltage step [V]	Disconnection time [s]	Limit [s]
L1	Stage 1 115% of $U_n$ = 264,5	266,0	230 to 269	60,4	≤61,0s
		266,0	230 to 269	60,3	
		266,0	230 to 269	60,2	
		266,0	230 to 269	60,3	
		266,0	230 to 269	60,4	
	Stage 2 125% of $U_n$ = 287.5	287,8	230 to 292	0,124	0,1s ≤ t ≤ 0,2s
		287,8	230 to 292	0,127	
		287,6	230 to 292	0,135	
		287,8	230 to 292	0,129	
		287,8	230 to 292	0,136	
	Stage 80% of $U_n$ = 184	184,0	230 to 189	4,04	2,0s ≤ t ≤ 5,0s
		184,0	230 to 189	4,02	
		184,0	230 to 189	4,06	
		184,1	230 to 189	4,02	
		184,1	230 to 189	4,04	
	Stage 2 50% of $U_n$ = 115	114,8	230 to 120	1,82	0,1s ≤ t ≤ 2,0s
		114,9	230 to 120	1,83	
		114,9	230 to 120	1,84	
		114,9	230 to 120	1,82	
		114,8	230 to 120	1,83	
L2	Stage 1 115% of $U_n$ = 264,5	264,7	230 to 269	60,3	≤61,0s
		264,5	230 to 269	60,2	
		264,6	230 to 269	60,1	
		264,9	230 to 269	60,1	
		264,9	230 to 269	60,1	
	Stage 2 125% of $U_n$ = 287.5	287,9	230 to 292	0,138	0,1s ≤ t ≤ 0,2s
		287,7	230 to 292	0,130	
		287,7	230 to 292	0,135	
		287,3	230 to 292	0,140	
		287,3	230 to 292	0,137	
	Stage	184,1	230 to 189	4,06	2,0s ≤ t ≤ 5,0s
		183,9	230 to 189	4,04	

	80% of $U_n$ = 184	184,0	230 to 189	4,08		
		184,1	230 to 189	4,02		
		184,0	230 to 189	4,04		
	Stage 2 50% of $U_n$ = 115	114,7	230 to 120	1,83	0,1s ≤ t ≤ 2,0s	
		114,7	230 to 120	1,84		
		114,8	230 to 120	1,82		
		114,8	230 to 120	1,83		
		114,8	230 to 120	1,81		
	L3	Stage 1 115% of $U_n$ = 264,5	265,9	230 to 269	60,2	≤61,0s
			265,9	230 to 269	60,1	
265,8			230 to 269	60,1		
265,9			230 to 269	60,2		
265,8			230 to 269	60,1		
Stage 2 125% of $U_n$ = 287.5		288,1	230 to 292	0,120	0,1s ≤ t ≤ 0,2s	
		287,8	230 to 292	0,123		
		287,4	230 to 292	0,130		
		287,9	230 to 292	0,125		
		287,9	230 to 292	0,132		
Stage 80% of $U_n$ = 184		185,0	230 to 189	4,04	2,0s ≤ t ≤ 5,0s	
		184,0	230 to 189	4,06		
		184,0	230 to 189	4,08		
		185,0	230 to 189	4,04		
		184,1	230 to 189	4,04		
Stage 2 50% of $U_n$ = 115		114,8	230 to 120	1,82	0,1s ≤ t ≤ 2,0s	
		114,9	230 to 120	1,82		
		114,9	230 to 120	1,85		
		115,0	230 to 120	1,85		
		115,0	230 to 120	1,84		

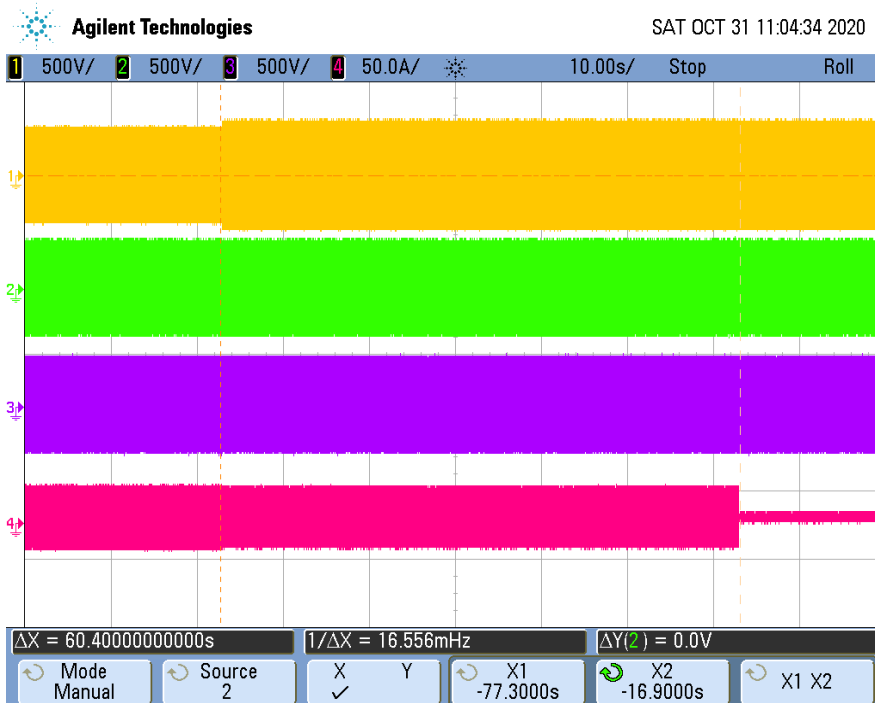
**Note:**

The trip values were evaluated by varying the applied voltage from  $U_n$  down to  $U_{th-low}$  - 2% of  $U_n$  in steps of 0,5% of  $U_n$  for under-voltage testing as well as from  $U_n$  up to  $U_{th-high}$  + 2% of  $U_n$  in steps of 0,5% of  $U_n$  for over-voltage testing, Lower and upper threshold voltage shall not fall or rise below or above 2,3V of the trip value itself, The disconnection time was measured by application of a negative voltage step from  $U_n$  to the operate value -5% of  $U_n$  as well as positive voltage step from  $U_n$  to the operate value +5% of  $U_n$ .

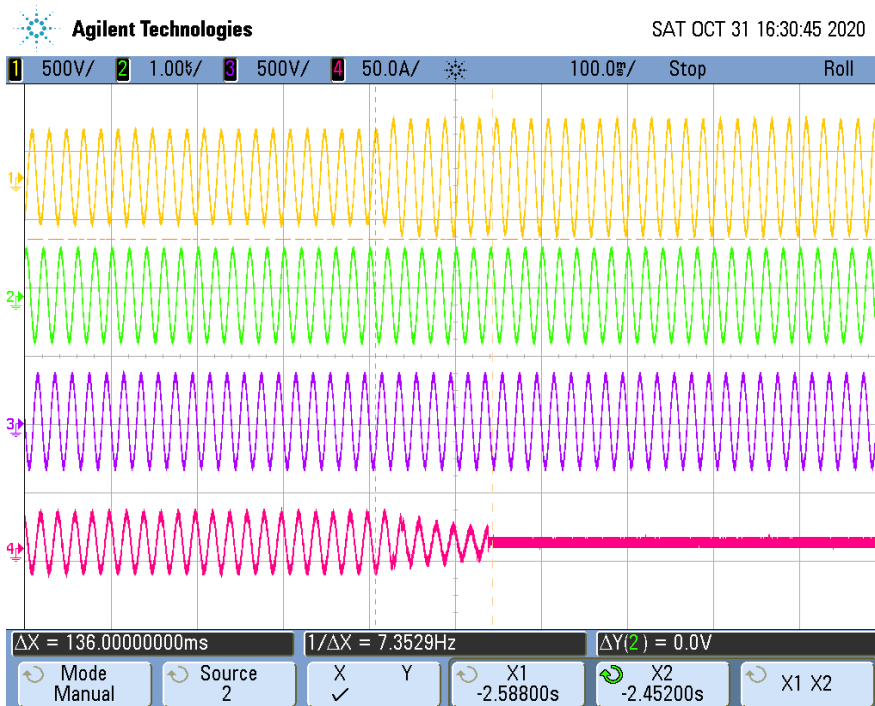
The tests had been performed on the SOFAR 24KTLX-G3 is valid for the SOFAR 15KTLX-G3, SOFAR 17KTLX-G3, SOFAR 20KTLX-G3 and SOFAR 22KTLX-G3, since it is identical in hardware and software construction except output power derated by software.

### Scope pictures of the disconnection time

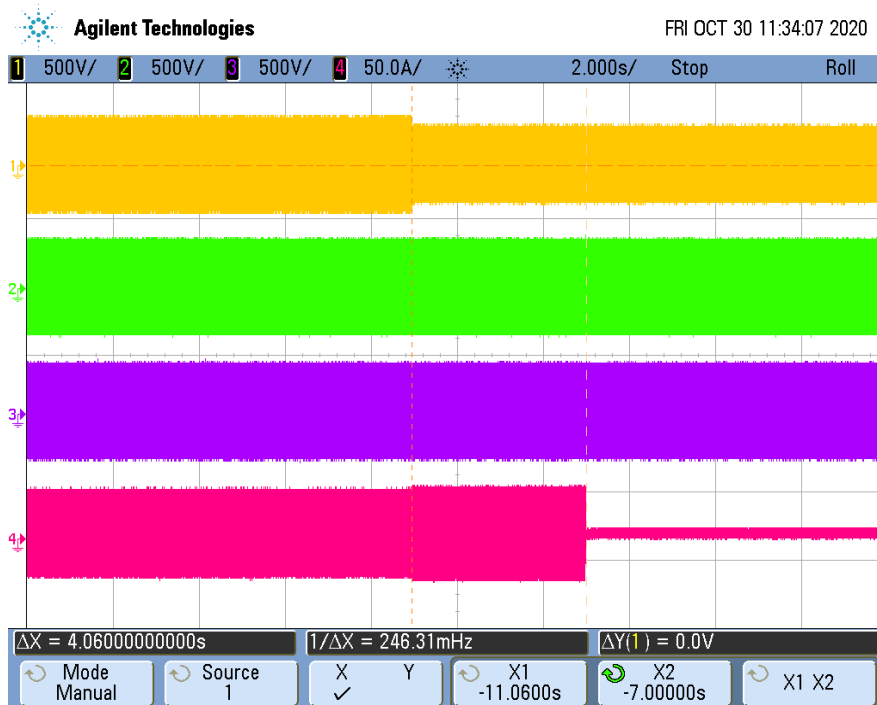
#### Over-voltage - Stage 1 (L1 phase)



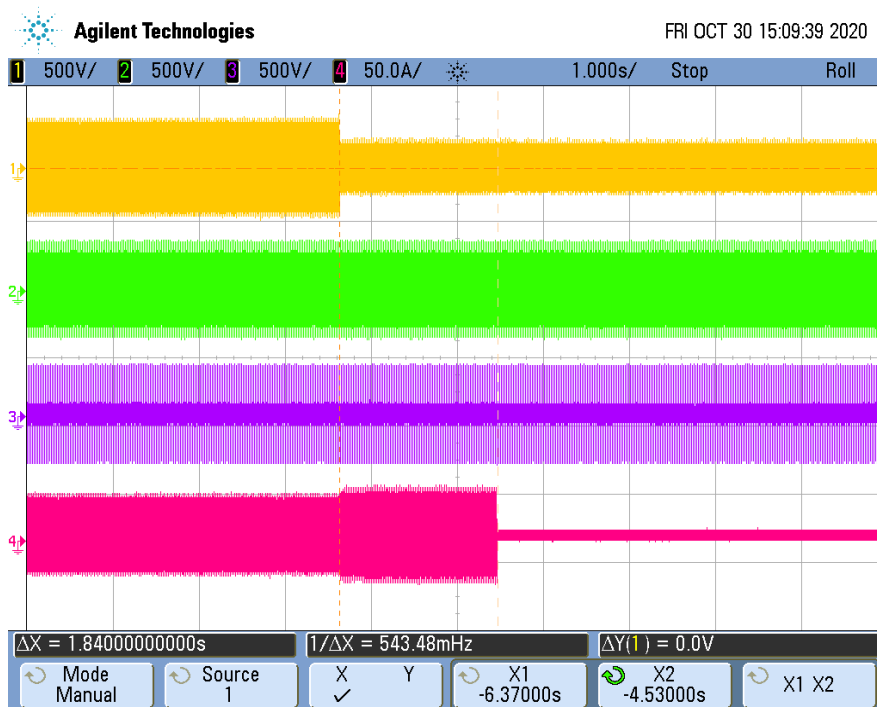
#### Over-voltage - Stage 2 (L1 phase)



Under-voltage - Stage 1 (L1 phase)

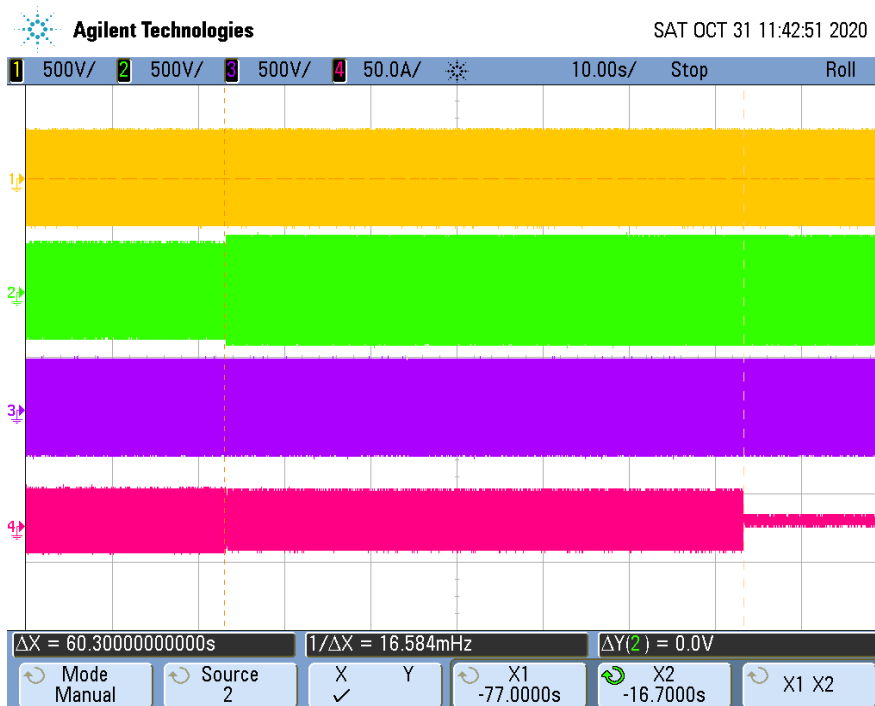


Under-voltage - Stage 2 (L1 phase)

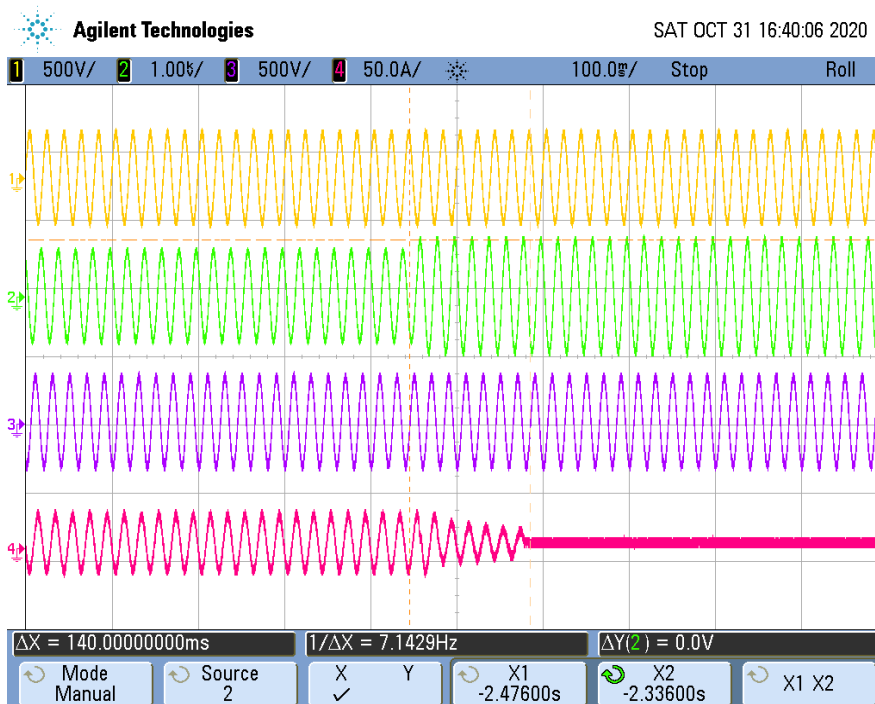




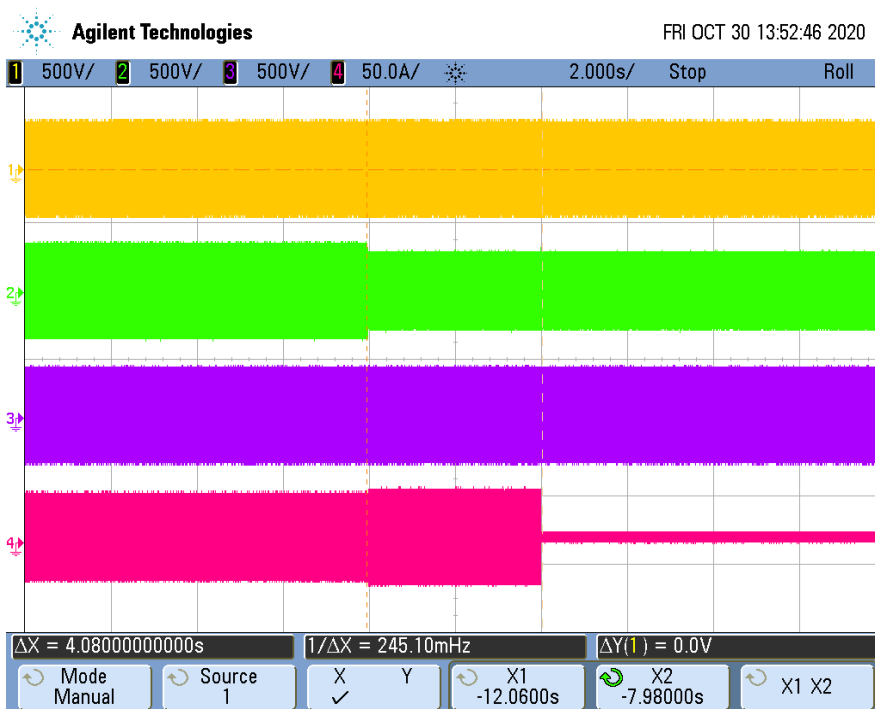
Over-voltage - Stage 1 (L2 phase)



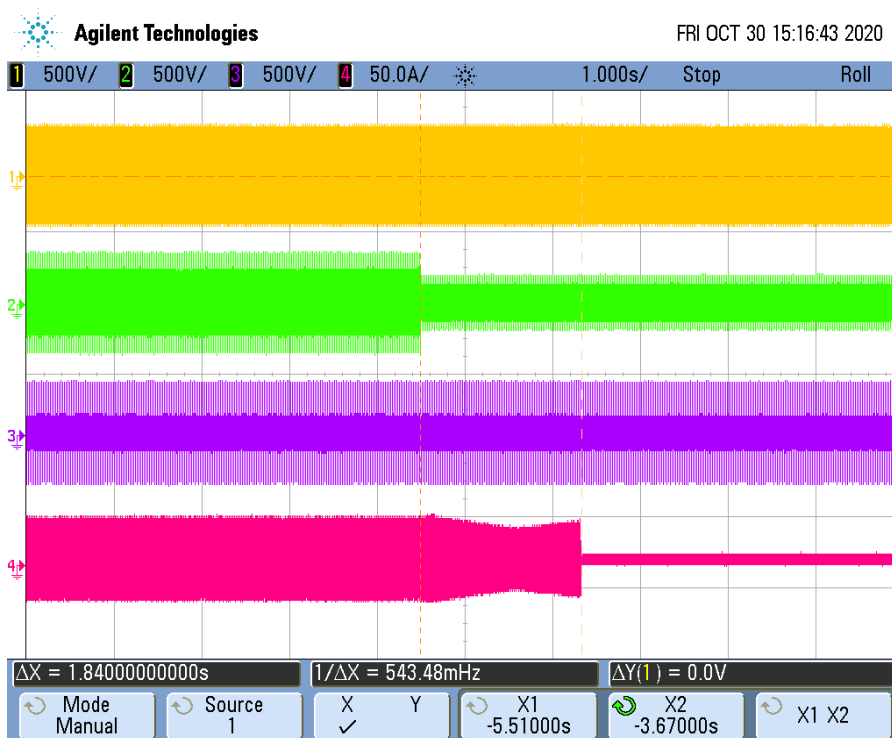
Over-voltage - Stage 2 (L2 phase)



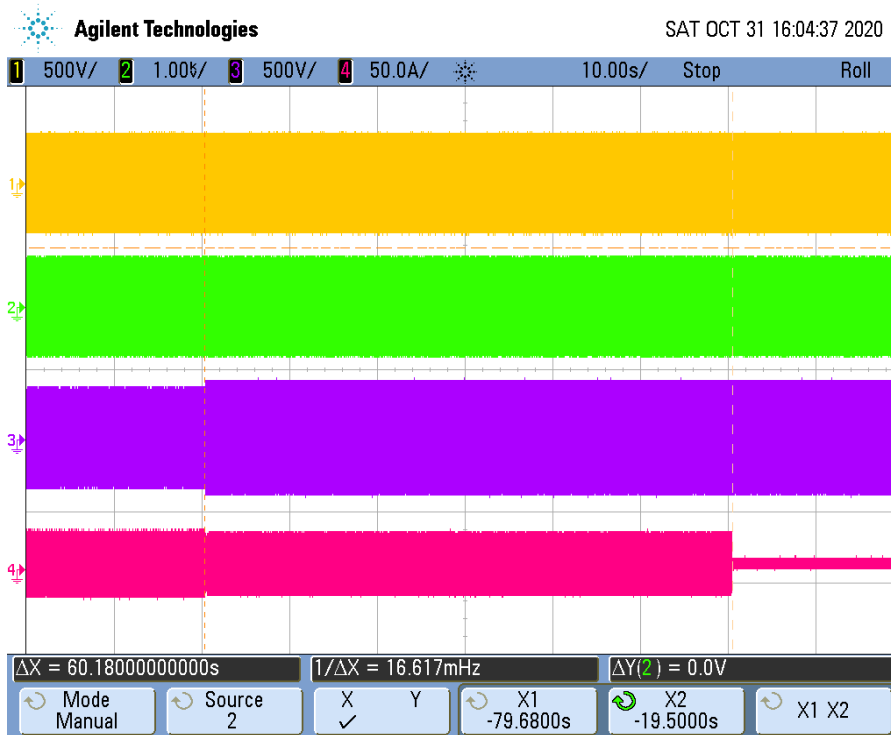
Under-voltage - Stage 1 (L2 phase)



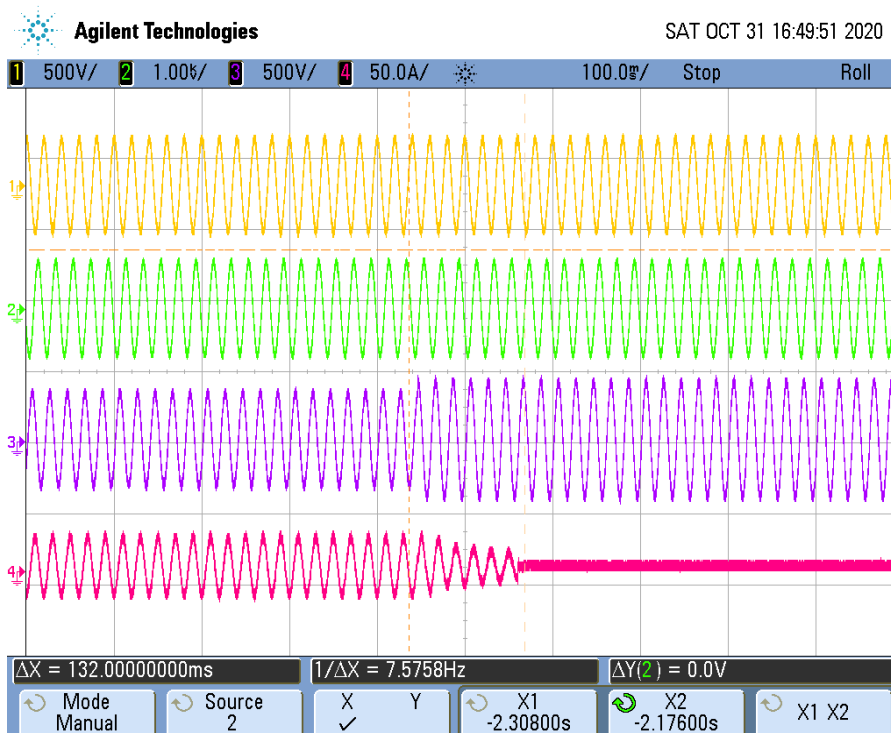
Under-voltage - Stage 2 (L2 phase)



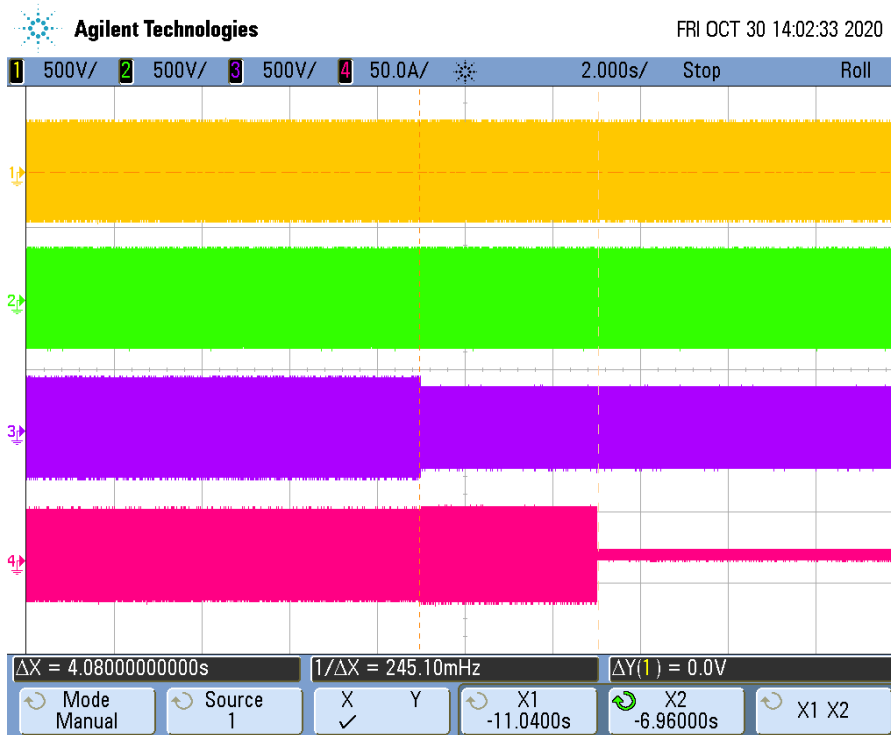
Over-voltage - Stage 1 (L3 phase)



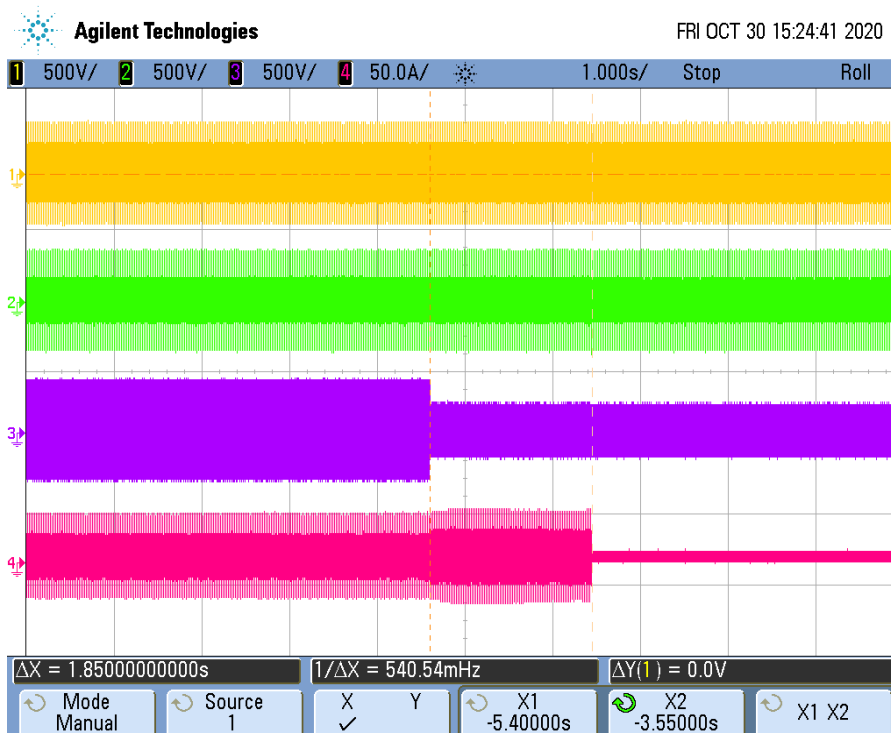
Over-voltage - Stage 2 (L3 phase)



Under-voltage - Stage 1 (L3 phase)



Under-voltage - Stage 2 (L3 phase)



4.9.3 Requirements on voltage and frequency protection					P
4.9.3.1 General (Interface protection: Over/under voltage) (Setting value refer EN 50438 default setting for Ireland)					
Test conditions			Output power: 12kW Frequency: 50+/-0,2Hz		
Phase	Limit [V]	Trip value [V]	Voltage step [V]	Disconnection time [s]	Limit [s]
L1	110% of Un = 253,0	254,67	230,0 to	0,485	0,5
		254,66	230,0 to	0,481	
		254,70	230,0 to	0,487	
		254,70	230,0 to	0,471	
		254,67	230,0 to	0,477	
	90% of Un = 207	206,80	230,0 to	0,480	0,5
		206,72	230,0 to	0,486	
		206,77	230,0 to	0,490	
		206,77	230,0 to	0,484	
		206,74	230,0 to	0,488	
L2	110% of Un = 253,0	253,79	230,0 to	0,470	0,5
		253,77	230,0 to	0,472	
		253,77	230,0 to	0,478	
		254,77	230,0 to	0,464	
		253,77	230,0 to	0,474	
	90% of Un = 207	206,81	230,0 to	0,478	0,5
		206,81	230,0 to	0,480	
		206,82	230,0 to	0,482	
		206,82	230,0 to	0,486	
		206,84	230,0 to	0,490	
L3	110% of Un = 253,0	253,84	230,0 to	0,473	0,5
		253,81	230,0 to	0,469	
		253,83	230,0 to	0,468	
		253,82	230,0 to	0,478	
		253,82	230,0 to	0,476	
	90% of Un = 207	206,89	230,0 to	0,490	0,5
		206,89	230,0 to	0,482	
		206,88	230,0 to	0,484	
		206,90	230,0 to	0,488	
		206,85	230,0 to	0,487	

**Note:**

The trip values were evaluated by varying the applied voltage from  $U_n$  down to  $U_{th-low} - 2\%$  of  $U_n$  in steps of 0,5% of  $U_n$  for under-voltage testing as well as from  $U_n$  up to  $U_{th-high} + 2\%$  of  $U_n$  in steps of 0,5% of  $U_n$  for over-voltage testing. Lower and upper threshold voltage shall not fall or rise below or above 2,3V of the trip value itself. The disconnection time was measured by application of a negative voltage step from  $U_n$  to the operate value - 5% of  $U_n$  as well as positive voltage step from  $U_n$  to the operate value + 5% of  $U_n$ .

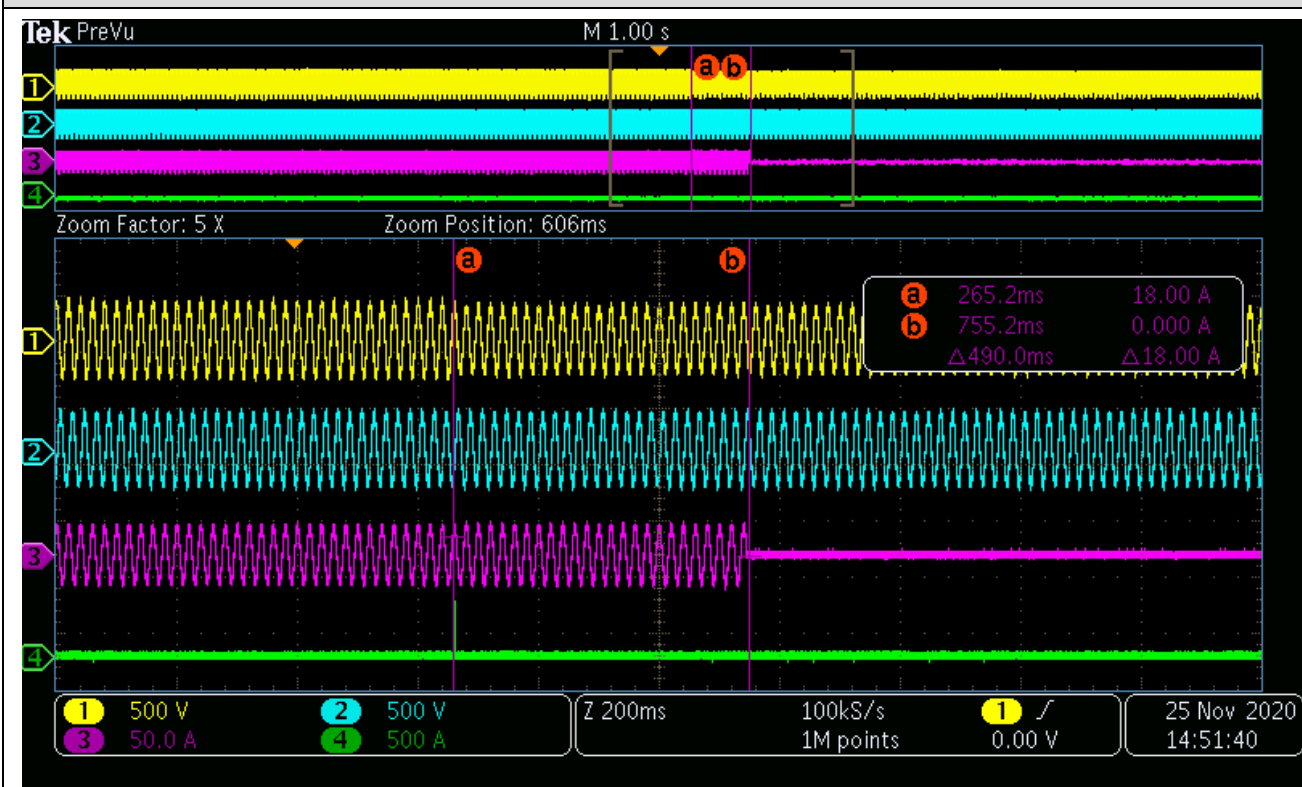
The tests had been performed on the SOFAR 24KTLX-G3 is valid for the SOFAR 15KTLX-G3, SOFAR 17KTLX-G3, SOFAR 20KTLX-G3 and SOFAR 22KTLX-G3, since it is identical in hardware and software construction except output power derated by software.

### Scope pictures of the disconnection time

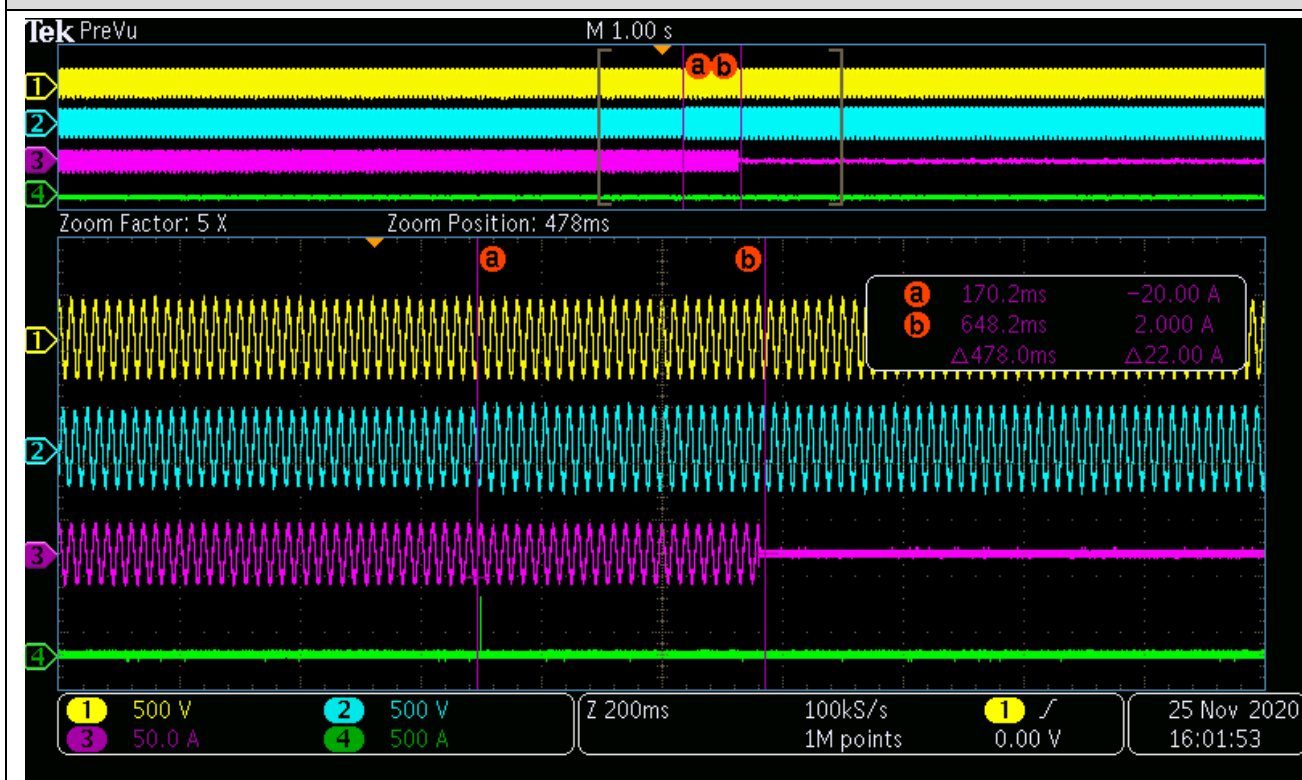
#### Over-voltage – Stage 1(L1 phase)



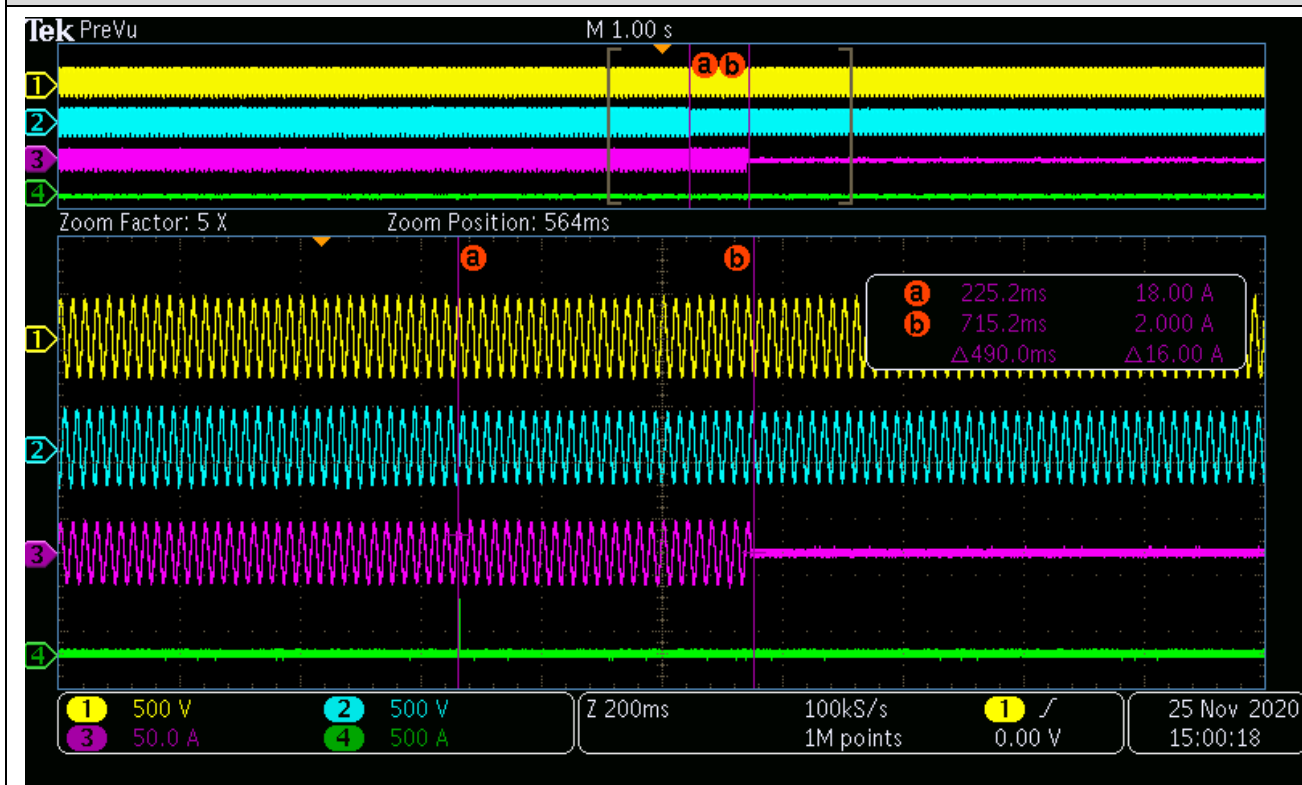
#### Under-voltage – Stage 1(L1 phase)



Over-voltage – Stage 1 (L2 phase)

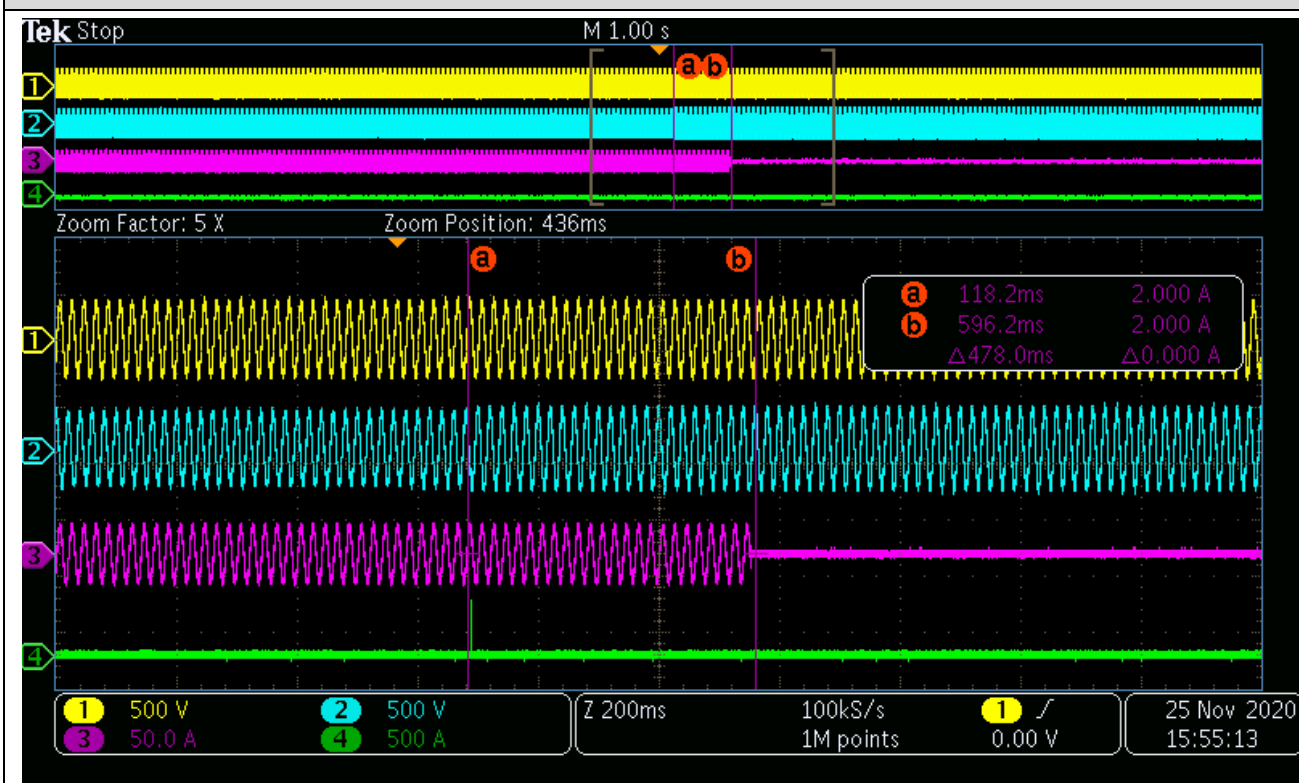


Under-voltage –Stage 1 (L2 phase)

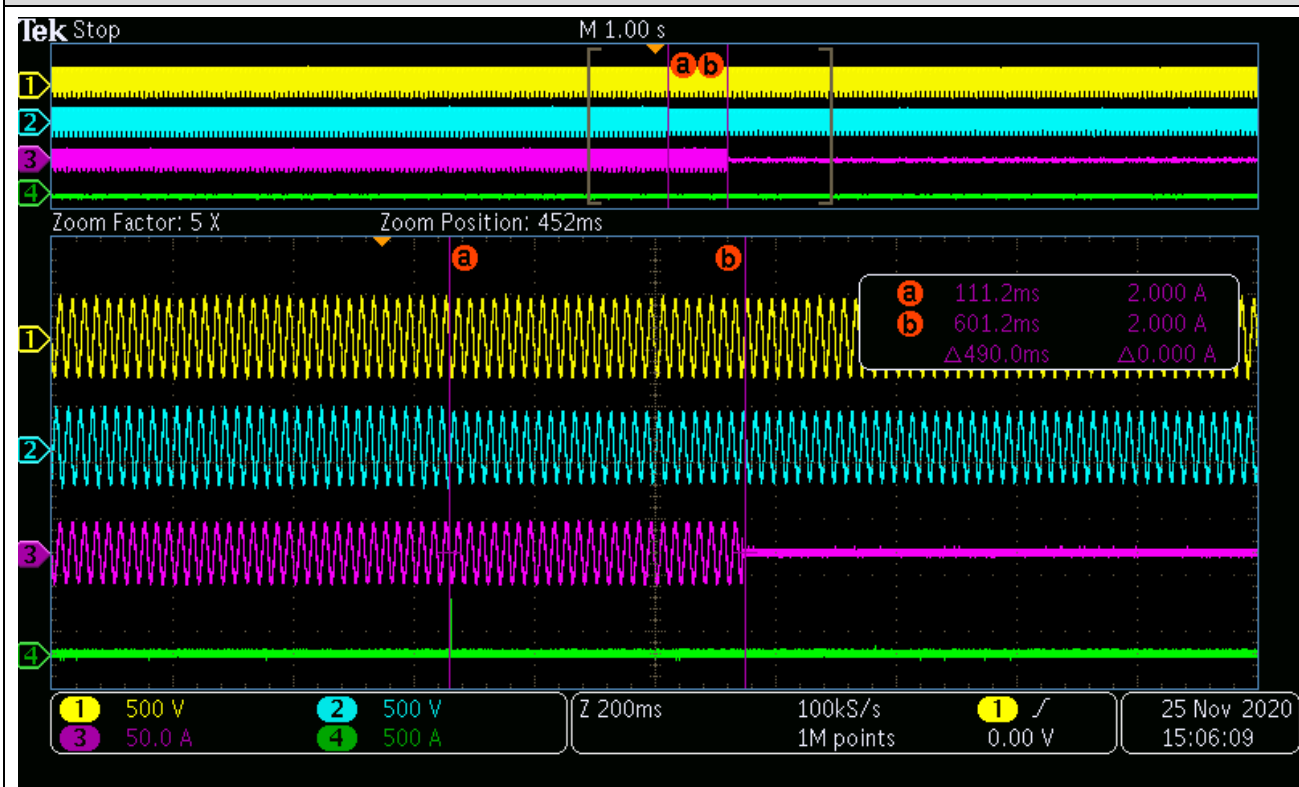




Over-voltage – Stage 1 (L3 phase)

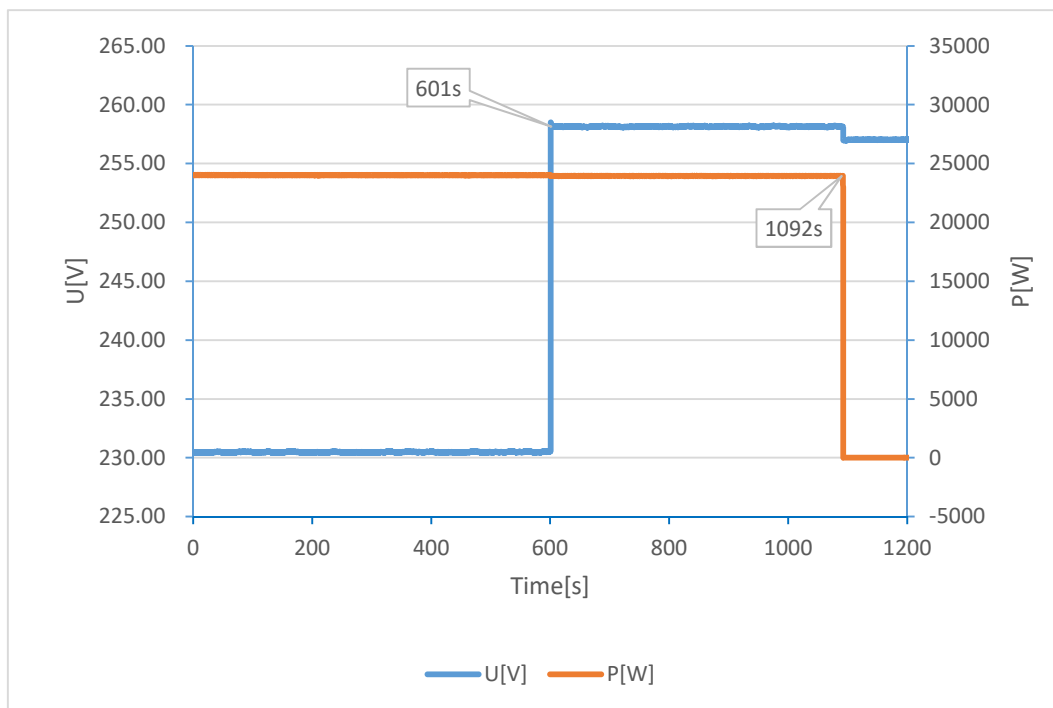


Under-voltage –Stage 1 (L3 phase)

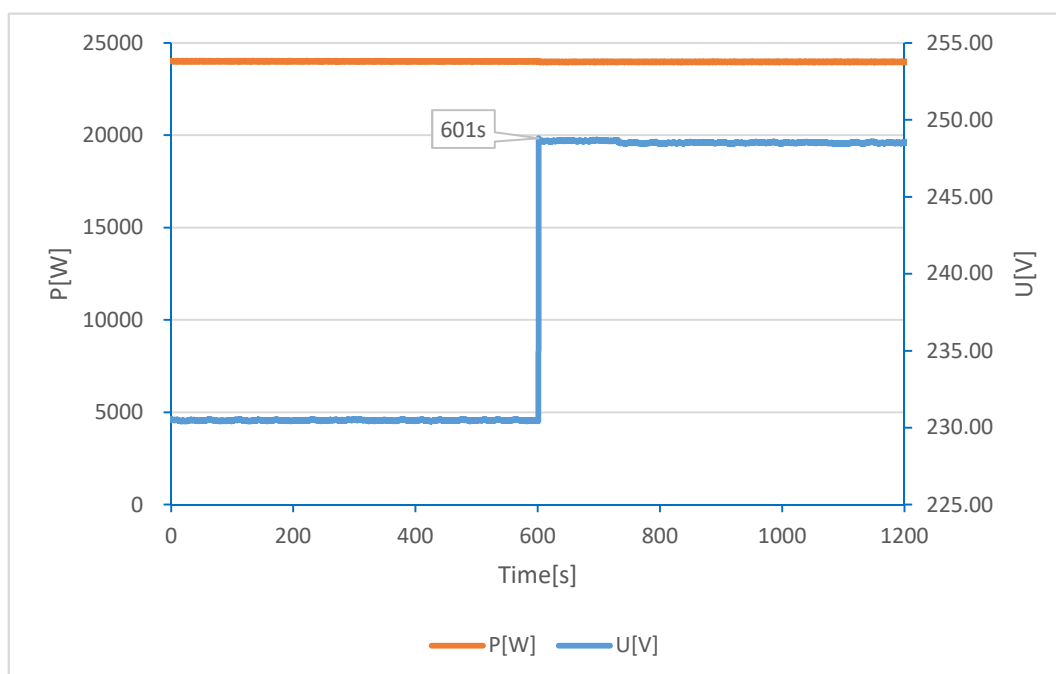


<b>4.9.3</b>	<b>Requirements on voltage and frequency protection</b>		<b>P</b>
<b>4.9.3.1</b>	<b>General</b> <b>(Maximum voltage 10 min mean protection according to EN 50160)</b> <b>(Setting value refer EN 50438 for default settings)</b>		
Setting values of the protection:	Trip value Setting [V]	253	
	Setting $T_{\text{disconnection trip value}}$ [s]	600	
	Setting $T_{\text{disconnection}}$ [ms]	200	
<b>Test:</b>			
	Disconnection time [s]	Limit [s]	
<b>a)</b>	The voltage is set to 100% $U_n$ and held for 600 s, Thereafter the voltage is set to 112% $U_n$ , Disconnection must take place within 600 s,		
	Phase 1:	491 s	≤ 600 s
	Phase 2:	486 s	
	Phase 3:	486 s	
<b>b)</b>	The voltage is set to $U_n$ for 600 s and then to 108% $U_n$ for 600 s, No disconnection should take place,		
	Phase 1:	No Disconnection	Disconnection should not take place,
	Phase 2:	No Disconnection	
	Phase 3:	No Disconnection	
<b>c)</b>	The voltage is set to 106 % $U_n$ and held for 600 s, Thereafter the voltage is set to 114 % $U_n$ , The disconnection should last for half the period as in Point a)*		
	Phase 1:	302 s	The disconnection time should be about 50 % of the value measured in a), *
	Phase 2:	294 s	
	Phase 3:	290 s	
<b>Test:</b>			
a) This test serves as proof of the measurement accuracy and the maximum set time.			
b) This test serves as proof of the measurement accuracy.			
c) This test serves as proof of the correct formation of the 1 minute running mean value.			
<b>Assessment criterion:</b>			
The permitted tolerance between setting value and trip value of the voltage may not exceed $\pm 1 \%$ of $U_N$ .			
<u>Limit values:</u>			
Rise-in voltage protection 1,1 $U_N$ after a max. 600 s, the switch off after 200 ms.			
<b>Note:</b>			
If only one integrated protection is used for the power generation systems, the value of the rise-in voltage protection of 1,1 $U_N$ may not be changed.			
*If the setting value is set to 600 s, then the disconnection time can be in the range between 225 s and 375 s.			
The tests had been performed on the SOFAR 24KTLX-G3 is valid for the SOFAR 15KTLX-G3, SOFAR 17KTLX-G3, SOFAR 20KTLX-G3 and SOFAR 22KTLX-G3, since it is identical in hardware and software construction except output power derated by software.			

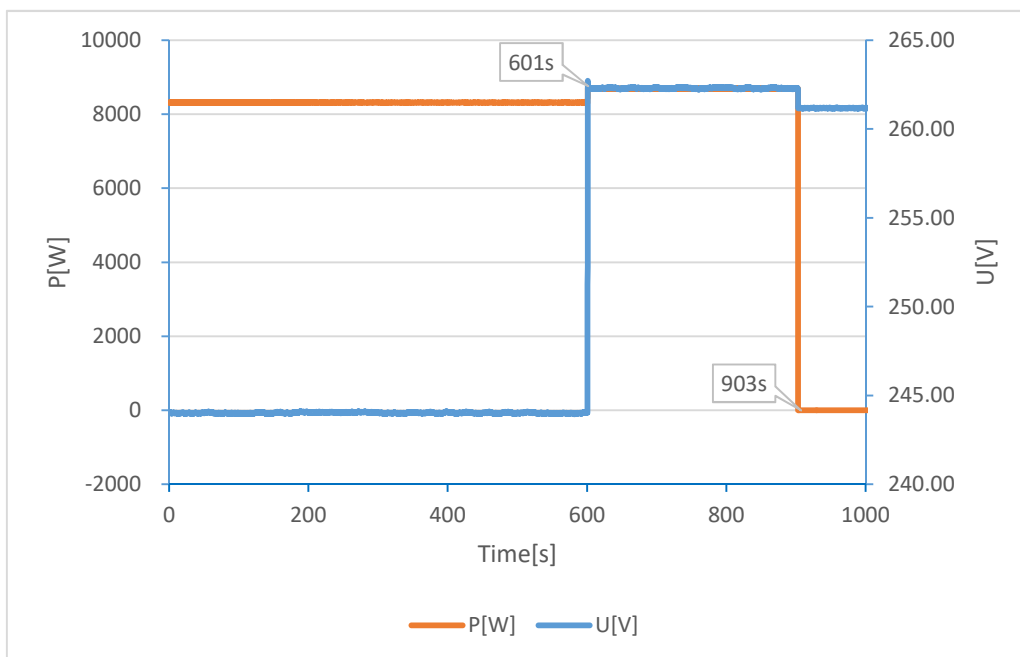
Graph of test a) Voltage set to 112 %  $U_n$



Graph of test b) Voltage set to 108%  $U_n$



Graph of test c) Voltage set to 106 %  $U_n$ , thereafter 114%  $U_n$



4.9.3 Requirements on voltage and frequency protection				P
4.9.3.1 General (Interface protection: Over/under frequency) (Setting value refer EN 50438 Default setting)				
Test conditions	Output power: 5,0kW $U_n = 230V_{ac}$			
	Under-frequency		Over-frequency	
Parameter	Stage 1 Under-Frequency	Time	Stage 1 Over-Frequency	Time
Limit	47,50 Hz	$0,3 \leq t \leq 0,5 \text{ s}$	51,50 Hz	$0,3 \leq t \leq 0,5 \text{ s}$
Trip value [Hz]	47,48		51,50	
	47,48		51,50	
	47,48		51,50	
	47,48		51,51	
	47,48		51,50	
Disconnection time [s]	50,00 Hz to 47,40 Hz	0,398	50,00 Hz to 51,60 Hz	0,396
		0,400		0,402
		0,402		0,392
		0,406		0,404
		0,405		0,400
Parameter	Stage 2 Under-Frequency	Time	Stage 2 Over-Frequency	Time
Limit	47,00 Hz	$0,1 \leq t \leq 0,2 \text{ s}$	52,00 Hz	$0,1 \leq t \leq 0,2 \text{ s}$
Trip value [Hz]	47,00		52,00	
	47,00		51,99	
	47,00		52,00	
	47,00		52,00	
	47,00		52,00	
Disconnection time [s]	50,00 Hz to 46,90 Hz	0,176	50,00 Hz to 52,10 Hz	0,173
		0,175		0,168
		0,170		0,176
		0,178		0,177
		0,182		0,170

**Note:**

For under-frequency testing the applied frequency is varied from  $f_n$  down to  $f_{th-low} - 0,1 \text{ Hz}$  in steps of  $0,025 \text{ Hz}$  with a time duration per step exceeding the configured disconnection time, The operate value is the value of the applied frequency at which the protection function trips and shall be within  $f_{th-low} \pm 0,05 \text{ Hz}$ .

For over-frequency testing the applied frequency is varied from  $f_n$  up to  $f_{th-high} + 0,1 \text{ Hz}$  in steps of  $0,025 \text{ Hz}$  with a time duration per step exceeding the configured disconnection time, The operate value is the value of the applied frequency at which the protection function trips and shall be within  $f_{th-high} \pm 0,05 \text{ Hz}$ .

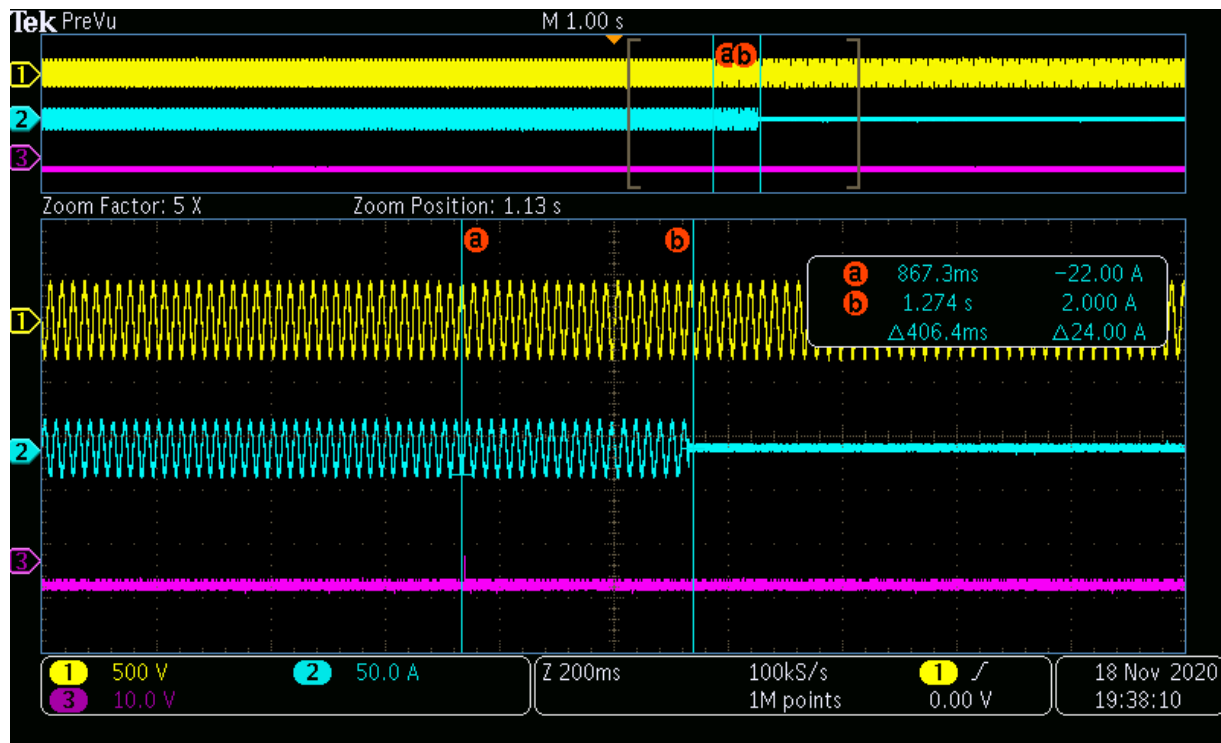
The disconnection time was measured by applying a negative or positive frequency ramp from  $f_n$  to the operate value  $-0,1$  Hz or  $+0,1$  Hz, e.g, from 50 Hz to 47,4 Hz, The time elapsed between the application of the frequency ramp and the opening of the interface switch was calculated by the measured time minus the 2500 ms from 50,0 Hz to 47,5 Hz.

The oscilloscope pictures below show the measured worst case disconnection times.

The tests had been performed on the SOFAR 24KTLX-G3 is valid for the SOFAR 15KTLX-G3, SOFAR 17KTLX-G3, SOFAR 20KTLX-G3 and SOFAR 22KTLX-G3, since it is identical in hardware and software construction except output power derated by software.

Scope pictures of the disconnection time

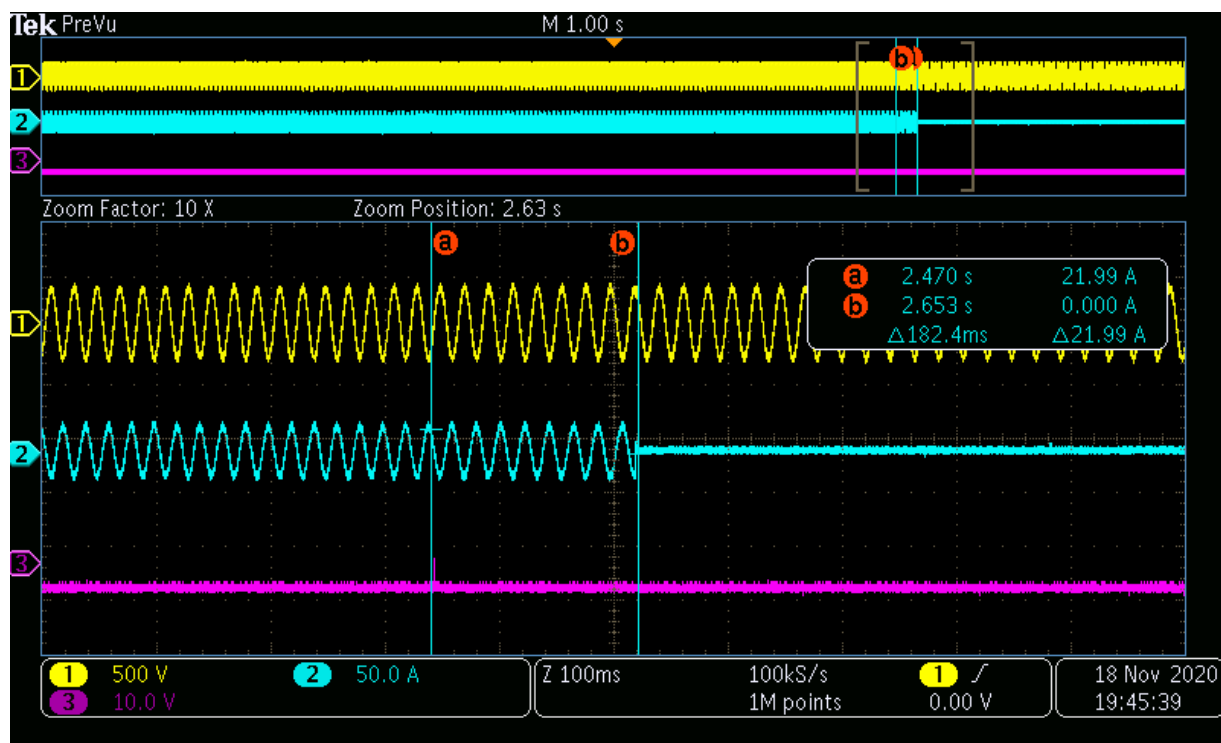
Under-frequency - Stage 1



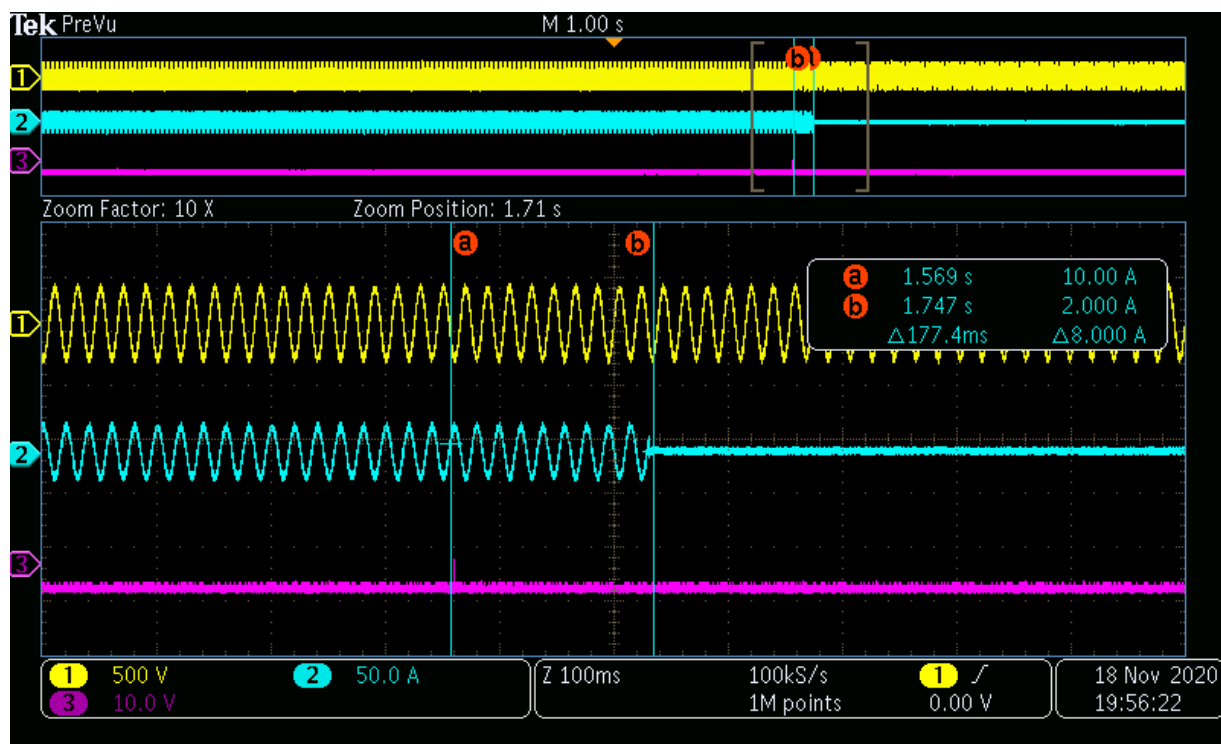
Over-frequency - Stage 1



### Under-frequency - Stage 2



### Over-frequency - Stage 2





4.9.3 Requirements on voltage and frequency protection				P
4.9.3.1 General (Interface protection: Over/under frequency) (Setting value refer EN 50438 default setting for Ireland)				
Test conditions	Output power: 12,0kW $U_n = 230V_{ac}$			
	Under-frequency		Over-frequency	
Parameter	Frequency	Time	Frequency	Time
Limit	48,00 Hz	0,5 s	50,50 Hz	0,5 s
Trip value [Hz]	47,99		50,50	
	47,99		50,50	
	47,99		50,50	
	47,99		50,50	
	47,99		50,50	
Disconnection time [ms]	48,1 Hz to 47,9 Hz	0,472	50,4 Hz to 50,6 Hz	0,480
		0,476		0,482
		0,484		0,472
		0,482		0,478
		0,480		0,476

**Note:**

For under-frequency testing the applied frequency is varied from  $f_n$  down to  $f_{th-low} - 0,1$  Hz in steps of 0,025 Hz with a time duration per step exceeding the configured disconnection time, The operate value is the value of the applied frequency at which the protection function trips and shall be within  $f_{th-low} \pm 0,05$  Hz.

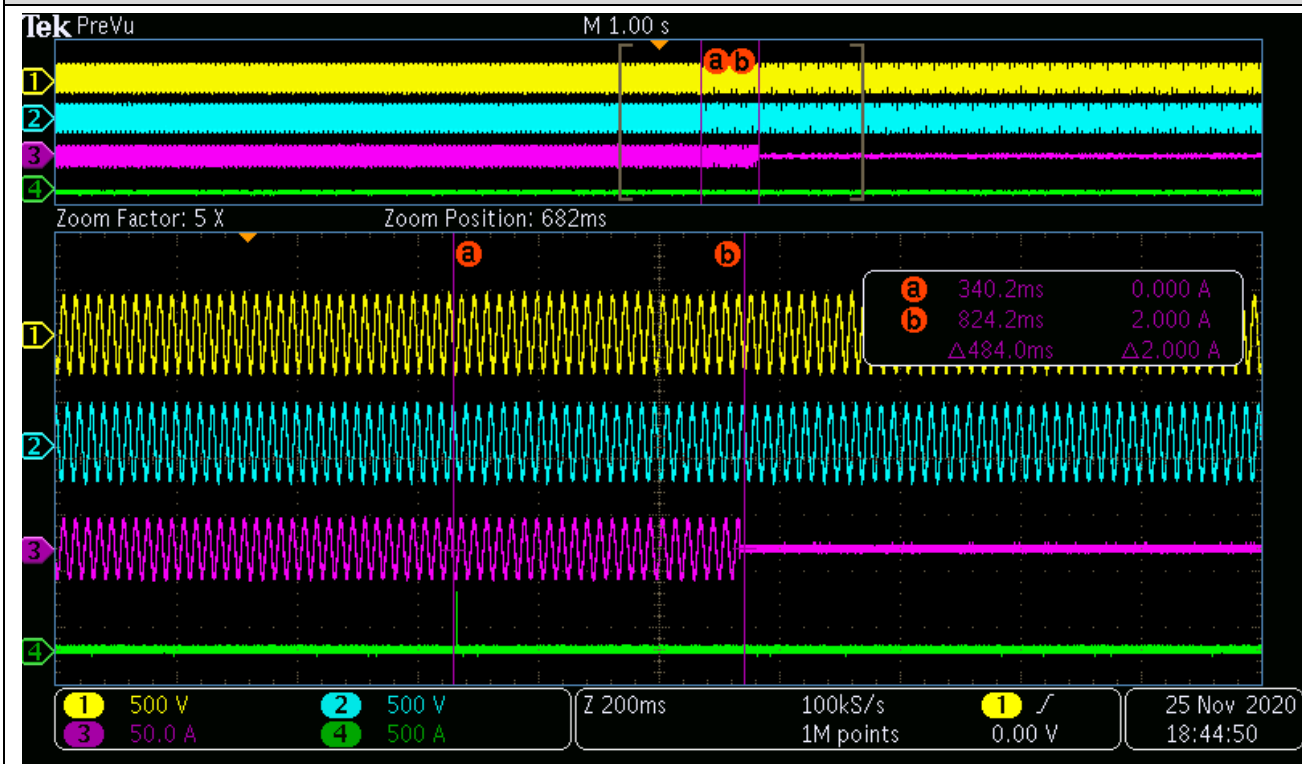
For over-frequency testing the applied frequency is varied from  $f_n$  up to  $f_{th-high} + 0,1$  Hz in steps of 0,025 Hz with a time duration per step exceeding the configured disconnection time, The operate value is the value of the applied frequency at which the protection function trips and shall be within  $f_{th-high} \pm 0,05$  Hz.

The oscilloscope pictures below show the measured worst case disconnection times.

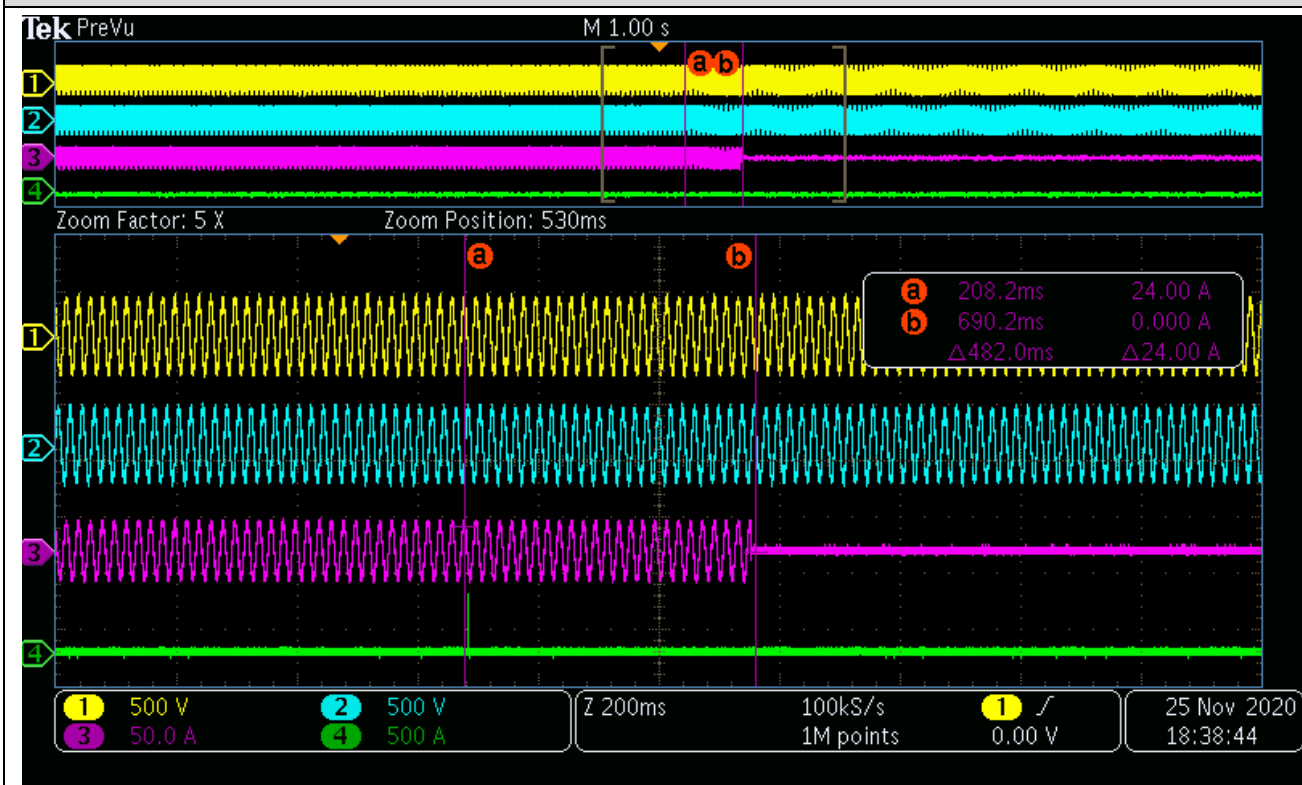
The tests had been performed on the SOFAR 24KTLX-G3 is valid for the SOFAR 15KTLX-G3, SOFAR 17KTLX-G3, SOFAR 20KTLX-G3 and SOFAR 22KTLX-G3, since it is identical in hardware and software construction except output power derated by software.

### Scope pictures of the disconnection time

#### Under-frequency



#### Over-frequency

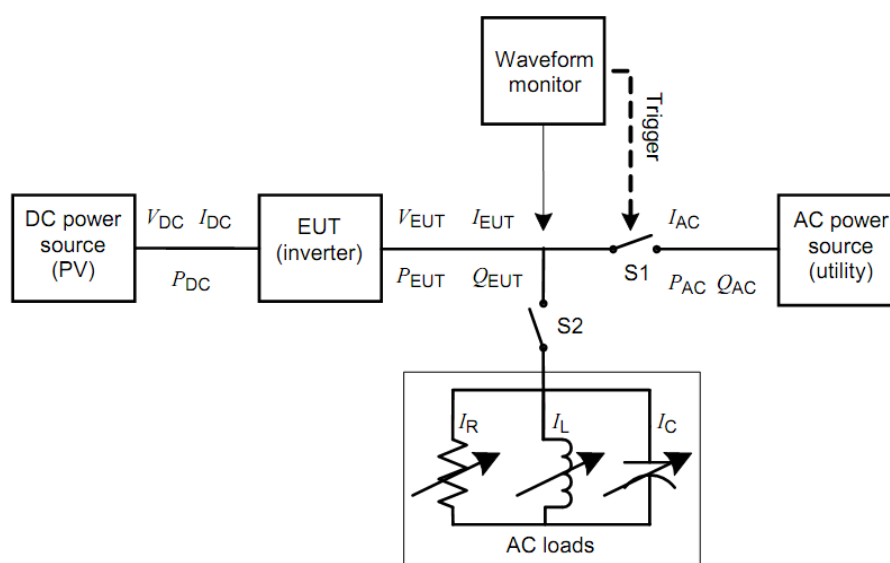


#### 4.9.4.2 Loss of Mains (LoM) detection

Test circuit and parameters

Parameter	Symbol	Units
<b>EUT DC Input</b>		
DC voltage	$V_{DC}$	V
DC Current	$I_{DC}$	A
DC Power	$P_{DC}$	W
<b>EUT AC output</b>		
AC voltage	$V_{EUT}$	V
AC current	$I_{EUT}$	A
Real power	$P_{EUT}$	W
Reactive power	$Q_{EUT}$	VA <sub>r</sub>
<b>Test Load</b>		
Resistive load current	$I_R$	A
Inductive load current	$I_L$	A
Capacitive load current	$I_C$	A
<b>AC (utility) power source</b>		
Utility real power	$P_{AC}$	W
Utility reactive power	$Q_{AC}$	VA <sub>r</sub>
Utility current	$I_{AC}$	A

Block diagram test circuit IEC 62116:2014



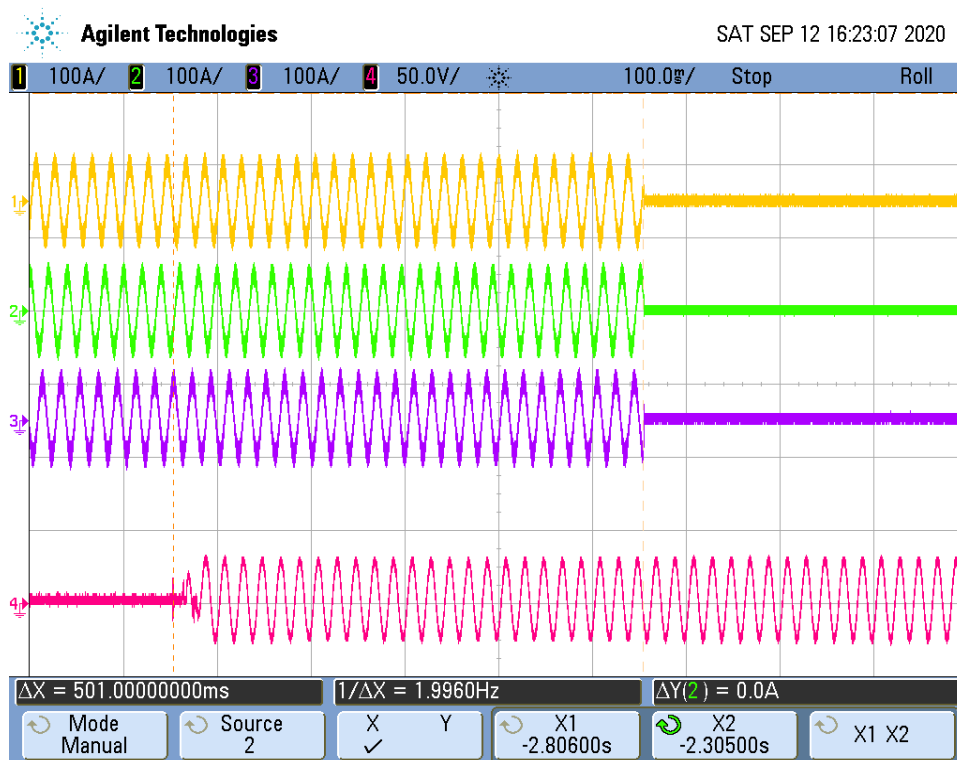
IEC 1567/08

**Figure 1 – Test circuit for islanding detection function in a power conditioner (inverter)**

Load imbalance (real, reactive load) for test condition A (EUT output = 100%)										P
Test :										
Test conditions			Frequency: 50+/-0,1Hz $U_N=230+/-3V_{ac}$ Distortion factor of chokes < 2% Quality = 1							
Disconnection limit			2s (IEC 62116)							
No	$P_{EUT}^{1)}$ [% of EUT rating]	Reactive load [% of $Q_L$ in 6,1,d) <sup>1)</sup>	$P_{AC}^{2)}$ [% of nominal]	$Q_{AC}^{3)}$ [% of nominal]	$I_{AC}^{4)}$ [A]	$P_{EUT}$ [W per phase]	$V_{DC}$ [V]	$Q_f$	Run on Time [ms]	Remarks <sup>5)</sup>
1	100	100	0	0	0,086	8000	695	1,002	501	BL
4	100	100	-5	-5	1,846	8000	695	1,028	449	IB
5	100	100	-5	0	1,891	8000	695	1,054	379	IB
6	100	100	-5	+5	1,844	8000	695	1,080	437	IB
7	100	100	0	-5	0,108	8000	695	0,976	438	IB
8	100	100	0	+5	0,107	8000	695	1,026	395	IB
9	100	100	+5	-5	1,802	8000	695	0,930	397	IB
10	100	100	+5	0	1,761	8000	695	0,954	469	IB
11	100	100	+5	+5	1,803	8000	695	0,978	416	IB
Parameter at 0% per phase			L= 21,01 mH		R= 6,61 $\Omega$		C= 482,46 $\mu F$			
<b>Note:</b>										
RLC is adjusted to min. +/-1% of the inverter rated output power										
1) $P_{EUT}$ : EUT output power.										
2) $P_{AC}$ : Real power flow at S1 in Figure 1. Positive means power from EUT to utility, Nominal is the 0 % test condition value.										
3) $Q_{AC}$ : Reactive power flow at S1 in Figure 1. Positive means power from EUT to utility, Nominal is the 0 % test condition value.										
4) Fundamental of $I_{AC}$ when RLC is adjusted.										
5) BL: Balance condition, IB: Imbalance condition.										
Condition A:										
EUT output power $P_{EUT} = \text{Maximum}^{6)}$										
EUT input voltage <sup>6)</sup> = >75% of rated input voltage range										
6) Maximum EUT output power condition should be achieved using the maximum allowable input power, Actual output power may exceed nominal rated output.										
7) Based on EUT rated input operating range, For example, If range is between X volts and Y volts, 75 % of range = $X + 0,75 \times (Y - X)$ , Y shall not exceed $0,8 \times$ EUT maximum system voltage (i.e., maximum allowable array open circuit voltage), In any case, the EUT should not be operated outside of its allowable input voltage range.										
The tests had been performed on the SOFAR 24KTLX-G3 is valid for the SOFAR 15KTLX-G3, SOFAR 17KTLX-G3, SOFAR 20KTLX-G3 and SOFAR 22KTLX-G3, since it is identical in hardware and software construction except output power derated by software.										

### Scope pictures of the disconnection time

Disconnection at No. 1

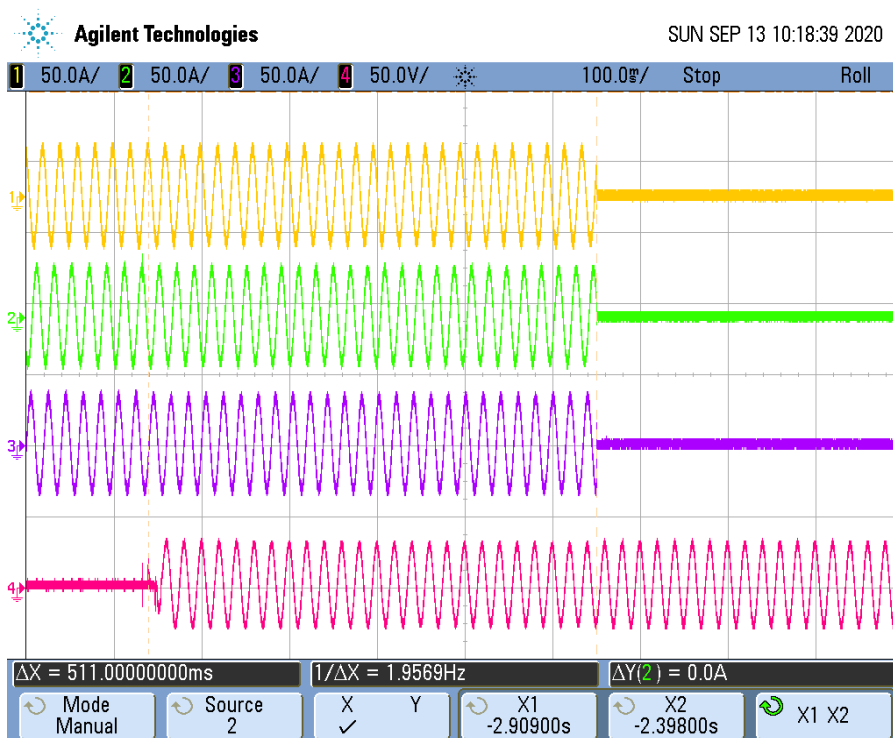


Load imbalance (reactive load) for test condition B (EUT output = 50 % – 66 %)										P
Test :										
Test conditions			Frequency: 50+/-0,1Hz $U_N=230+/-3V_{ac}$ Distortion factor of chokes < 2% Quality =1							
Disconnection limit			2s (IEC 62116)							
No	$P_{EUT}^{1)}$ [% of EUT rating]	Reactive load [% of $Q_L$ in 6,1,d) <sup>1)</sup>	$P_{AC}^{2)}$ [% of nominal]	$Q_{AC}^{3)}$ [% of nominal]	$I_{AC}^{4)}$ [A]	$P_{EUT}$ [W per phase]	$V_{DC}$ [V]	$Q_f$	Run on Time [ms]	Remarks <sup>5)</sup>
12	66	66	0	-5	0,218	5280	510	0,975	413	IB
13	66	66	0	-4	0,208	5280	510	0,980	481	IB
14	66	66	0	-3	0,200	5280	510	0,985	469	IB
15	66	66	0	-2	0,194	5280	510	0,990	463	IB
16	66	66	0	-1	0,190	5280	510	0,995	384	IB
<b>2</b>	<b>66</b>	<b>66</b>	<b>0</b>	<b>0</b>	0,089	5280	510	1,000	511	<b>BL</b>
17	66	66	0	1	0,190	5280	510	1,005	480	IB
18	66	66	0	2	0,193	5280	510	1,010	500	IB
19	66	66	0	3	0,199	5280	510	1,015	484	IB
20	66	66	0	4	0,207	5280	510	1,020	489	IB
21	66	66	0	5	0,217	5280	510	1,025	474	IB
Parameter at 0% per phase			L= 31,75 mH		R= 9,98 $\Omega$			C= 319,21 $\mu F$		
<b>Note:</b>										
RLC is adjusted to min. +/-1% of the inverter rated output power										
1) $P_{EUT}$ : EUT output power.										
2) $P_{AC}$ : Real power flow at S1 in Figure 1, Positive means power from EUT to utility, Nominal is the 0 % test condition value.										
3) $Q_{AC}$ : Reactive power flow at S1 in Figure 1, Positive means power from EUT to utility, Nominal is the 0 % test condition value.										
4) Fundamental of $I_{AC}$ when RLC is adjusted.										
5) BL: Balance condition, IB: Imbalance condition.										
Condition B:										
EUT output power $P_{EUT} = 50 \% - 66 \%$ of maximum										
EUT input voltage <sup>6)</sup> = 50 % of rated input voltage range, $\pm 10 \%$										
6) Based on EUT rated input operating range, For example, If range is between X volts and Y volts, 50 % of range = $X + 0,5 \times (Y - X)$ , Y shall not exceed $0,8 \times$ EUT maximum system voltage (i.e., maximum allowable array open circuit voltage), In any case, the EUT should not be operated outside of its allowable input voltage range.										
The tests had been performed on the SOFAR 24KTLX-G3 is valid for the SOFAR 15KTLX-G3, SOFAR 17KTLX-G3, SOFAR 20KTLX-G3 and SOFAR 22KTLX-G3, since it is identical in hardware and software										

construction except output power derated by software. The test results refer to the original test report PV191016N002-1 issued by Bureau Veritas Shenzhen Co., Ltd. Dongguan Branch, dated on 2019-11-04.

### Scope pictures of the disconnection time

Disconnection at No. 2



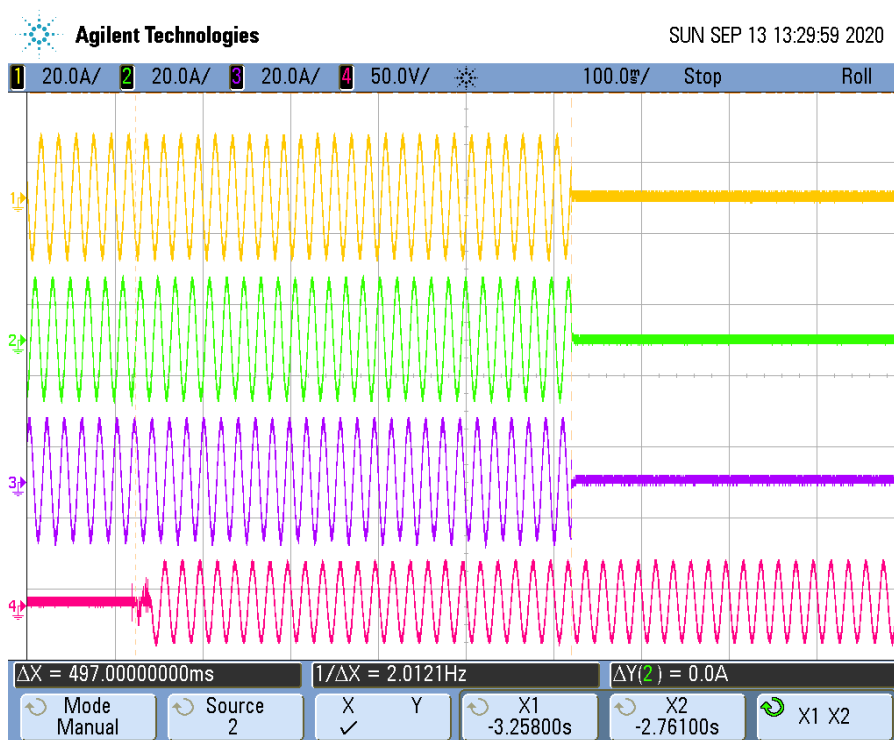
Load imbalance (reactive load) for test condition C (EUT output = 25 % – 33 %)										P
Test :										
Test conditions			Frequency: 50+/-0,1Hz $U_N=230+/-3V_{ac}$ Distortion factor of chokes < 2% Quality =1							
Disconnection limit			2s (IEC 62116)							
No	$P_{EUT}^{1)}$ [% of EUT rating]	Reactive load [% of $Q_L$ in 6,1,d) <sup>1)</sup>	$P_{AC}^{2)}$ [% of nominal]	$Q_{AC}^{3)}$ [% of nominal]	$I_{AC}^{4)}$ [A]	$P_{EUT}$ [W per phase]	$V_{DC}$ [V]	$Q_f$	Run on Time [ms]	Remarks <sup>5)</sup>
22	33	33	0	-5	0,511	2640	288	0,974	411	IB
23	33	33	0	-4	0,506	2640	288	0,979	487	IB
24	33	33	0	-3	0,502	2640	288	0,984	368	IB
25	33	33	0	-2	0,499	2640	288	0,989	418	IB
26	33	33	0	-1	0,497	2640	288	0,994	410	IB
<b>3</b>	<b>33</b>	<b>33</b>	<b>0</b>	<b>0</b>	0,483	2640	288	0,999	497	<b>BL</b>
27	33	33	0	1	0,496	2640	288	1,004	372	IB
28	33	33	0	2	0,498	2640	288	1,009	439	IB
29	33	33	0	3	0,501	2640	288	1,014	348	IB
30	33	33	0	4	0,505	2640	288	1,019	445	IB
31	33	33	0	5	0,510	2640	288	1,024	414	IB
Parameter at 0% per phase			L= 63,71 mH		R= 20,02 $\Omega$			C= 158,85 $\mu F$		
<b>Note:</b>										
RLC is adjusted to min. +/-1% of the inverter rated output power										
1) $P_{EUT}$ : EUT output power.										
2) $P_{AC}$ : Real power flow at S1 in Figure 1, Positive means power from EUT to utility, Nominal is the 0 % test condition value.										
3) $Q_{AC}$ : Reactive power flow at S1 in Figure 1, Positive means power from EUT to utility, Nominal is the 0 % test condition value.										
4) Fundamental of $I_{AC}$ when RLC is adjusted.										
5) BL: Balance condition, IB: Imbalance condition.										
Condition B:										
EUT output power $P_{EUT} = 25 \% - 33 \%$ <sup>6)</sup> of maximum										
EUT input voltage <sup>7)</sup> = <20 % of rated input voltage range										
6) Or minimum allowable EUT output level if greater than 33 %.										
7) Based on EUT rated input operating range, For example, If range is between X volts and Y volts, 20 % of range = $X + 0,2 \times (Y - X)$ , Y shall not exceed $0,8 \times$ EUT maximum system voltage (i.e., maximum allowable array open circuit voltage), In any case, the EUT should not be operated outside of its allowable input voltage range.										



The tests had been performed on the SOFAR 24KTLX-G3 is valid for the SOFAR 15KTLX-G3, SOFAR 17KTLX-G3, SOFAR 20KTLX-G3 and SOFAR 22KTLX-G3, since it is identical in hardware and software construction except output power derated by software.

### Scope pictures of the disconnection time

Disconnection at No. 3



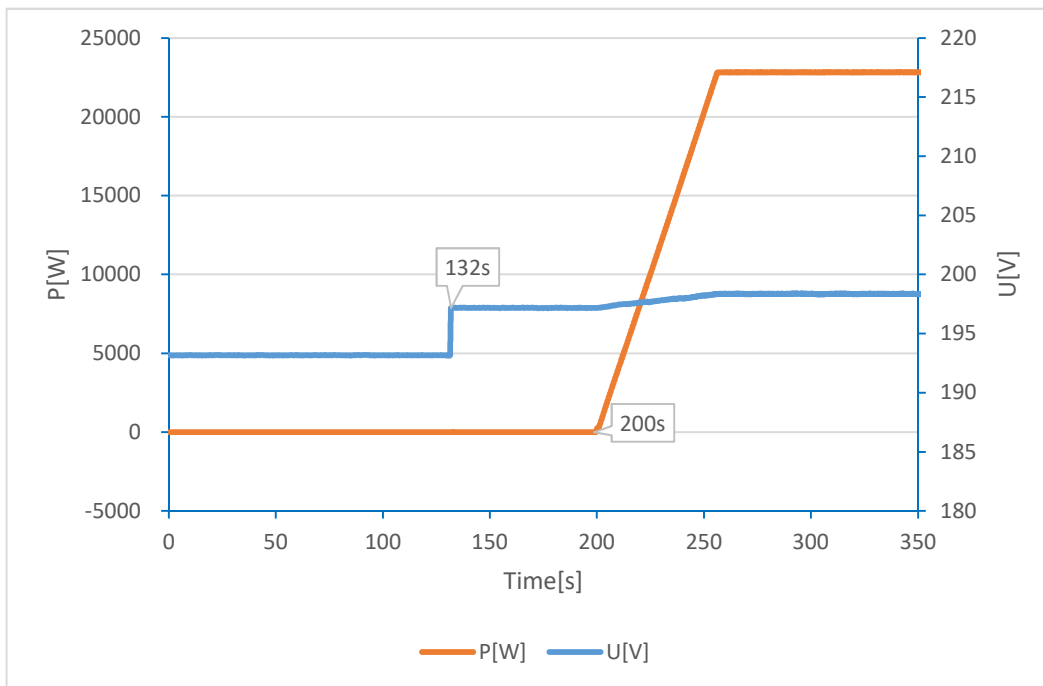
## EN 50549-1:2019: Connection and starting to generate electrical power

Clause	Test requirement	Test procedure according standard	Result
4.10.2	Automatic reconnection after tripping	EN 50438, Annex D.3.6	<b>P</b>
4.10.3	Starting to generate electrical power	EN 50438, Annex D.3.6	<b>P</b>

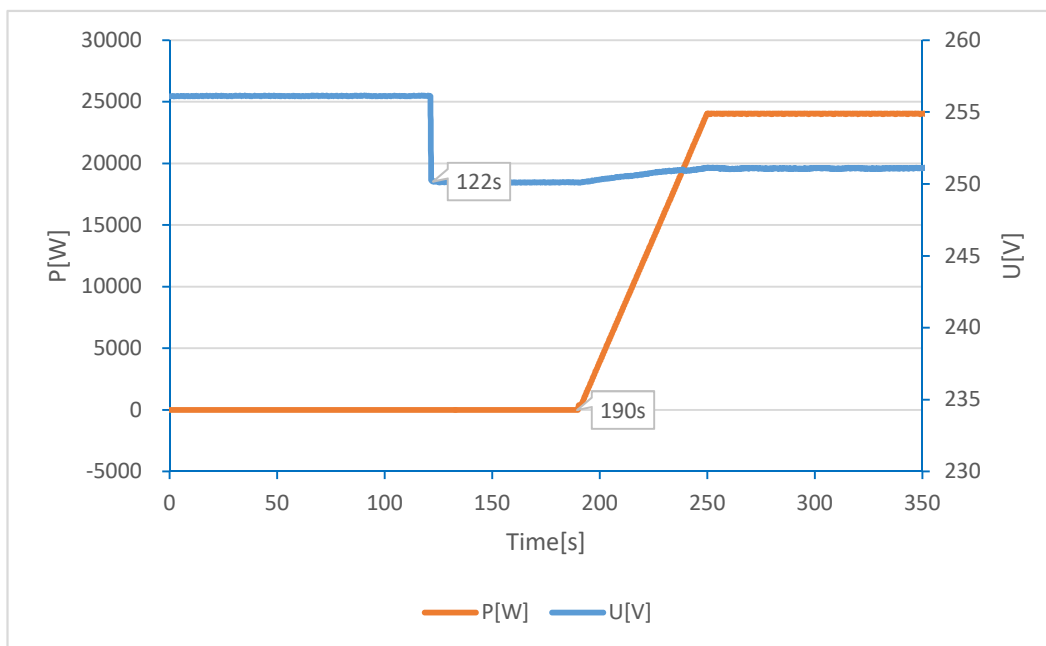
4.10 Connection and starting to generate electrical power		P
4.10.2 Automatic reconnection after tripping		
4.10.3 Starting to generate electrical power		
Setting value	Min. voltage for connected to grid :	196
	Max. voltage for connected to grid :	253
	Min. frequency for connected to grid :	49,5
	Max. frequency for connected to grid (Normal operational start-up) :	50,1
	Max. frequency for connected to grid (Automatic reconnection after tripping) :	50,2
	Observation time ( $\geq 60$ s) :	60
<b>Test:</b>		
<b>Voltage conditons</b>		
a) Start up for voltage range	<85% $U_n$ for twice of observation time	>110% $U_n$ for twice of observation time
Connection:	No connection	No connection
Limit	No connection allowed	
b) In voltage range at start-up	$\geq 85\% U_n$ within twice setting observation time	$\leq 110\% U_n$ within twice setting observation time
Reconnection time [s]	68,0 s	68,0 s
Limit:	Connected after setting observation time ( $\geq 60$ s)	
Gradient:	The maximum occurring active power gradient after connection respectively start generating electrical power is less than the configured maximum active power per minute Max gradient: disable, For recorded gradient see diagram below,	
c) In voltage range after voltage failure	$\geq 85\% U_n$ for twice of setting observation time	$\leq 110\% U_n$ for twice of setting observation time
Reconnection time [s]	76,0 s	76,0 s
Limit:	Reconnection after setting observation time ( $\geq 60$ s)	
Gradient:	For adjustable micro generators the maximum occurring active power gradient after connection respectively start generating electrical power is less than the configured maximum active power per minute Max gradient: $10\% P_{Emax}/min$ . For non or partly adjustable generators the connection after trip of the interface protection is delayed by a randomised value between 1 min and 10 min. For recorded gradient see diagram below.	

	Frequency conditions	
d) Start up for frequency range	<49,50 Hz for twice of setting observation time	>50,10 Hz for twice of setting observation time
Connection:	No connection	No connection
Limit	No connection allowed	
e) In frequency range at start-up	≥49,50 Hz within twice of setting observation time	≤50,10 Hz within twice of setting observation time
Reconnection time [s]	69,0 s	68,0 s
Limit:	Connected after setting delay time(≥60s)	
Gradient:	The maximum occurring active power gradient after connection respectively start generating electrical power is less than the configured maximum active power per minute Max gradient: disable. For recorded gradient see diagram below.	
f) In frequency range after frequency failure	≥49,50 Hz for twice of setting observation time	≤50,20 Hz for twice of setting observation time
Reconnection time [s]	75,0 s	68,0 s
Limit:	Reconnection after setting observation time (≥60s)	
Gradient:	For adjustable micro generators the maximum occurring active power gradient after connection respectively start generating electrical power is less than the configured maximum active power per minute Max gradient: 10%P <sub>E<sub>max</sub></sub> /min. For non or partly adjustable generators the connection after trip of the interface protection is delayed by a randomised value between 1 min and 10 min. For recorded gradient see diagram below.	
<p><b>Test:</b></p> <p>Test condition b) and c): voltage within the limits of 85% to 110%U<sub>n</sub>.</p> <p>Test condition e): frequency within the limits of 49,50Hz to 50,1Hz.</p> <p>Test condition f): frequency within the limits of 49,50Hz to 50,2Hz.</p> <p>In order to avoid continuous starting and disengaging operations of the interface protection relay, the disengaging value of frequency and voltage functions shall be above 2 % deviating from the operate value.</p> <p>The tests had been performed on the SOFAR 24KTLX-G3 is valid for the SOFAR 15KTLX-G3, SOFAR 17KTLX-G3, SOFAR 20KTLX-G3 and SOFAR 22KTLX-G3, since it is identical in hardware and software construction except output power derated by software.</p>		
<p><b>Assessment criterion:</b></p> <p>a) the micro generator connects respectively starts generating electrical power only in the permitted range of voltage and frequency and</p> <p>b) for adjustable micro generators the maximum occurring active power gradient after connection respectively start generating electrical power is less than the configured maximum active power per minute and</p> <p>c) for non or partly adjustable generators the connection after trip of the interface protection is delayed by a randomised value between 1 min and 10 min.</p>		

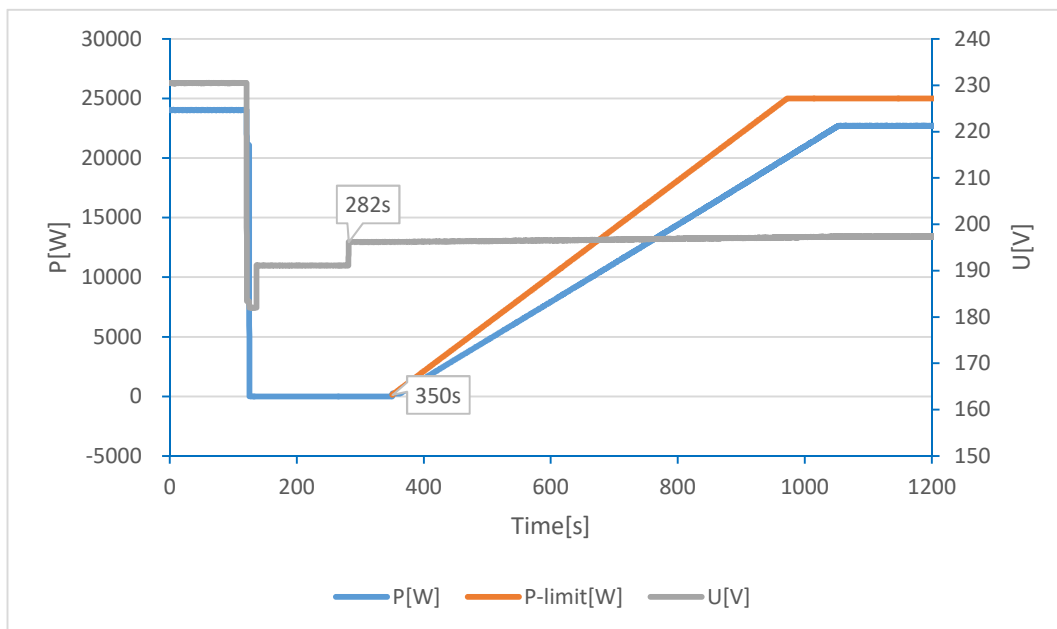
**Graph of the gradual power supply : Test b) for  $\geq 85\% U_n$**



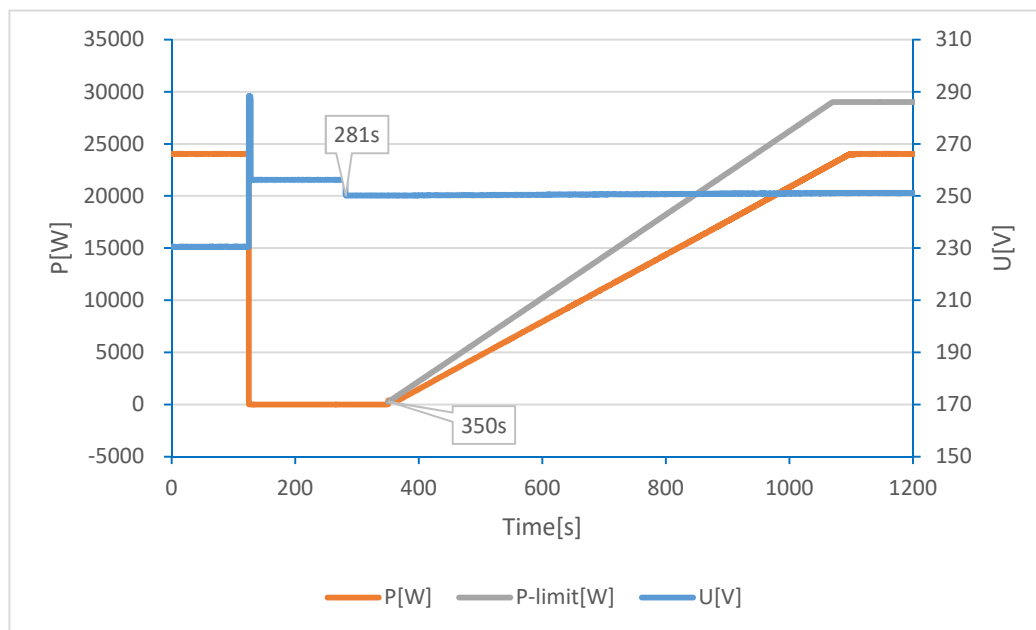
**Graph of the gradual power supply : Test b) for  $\leq 110\% U_n$**



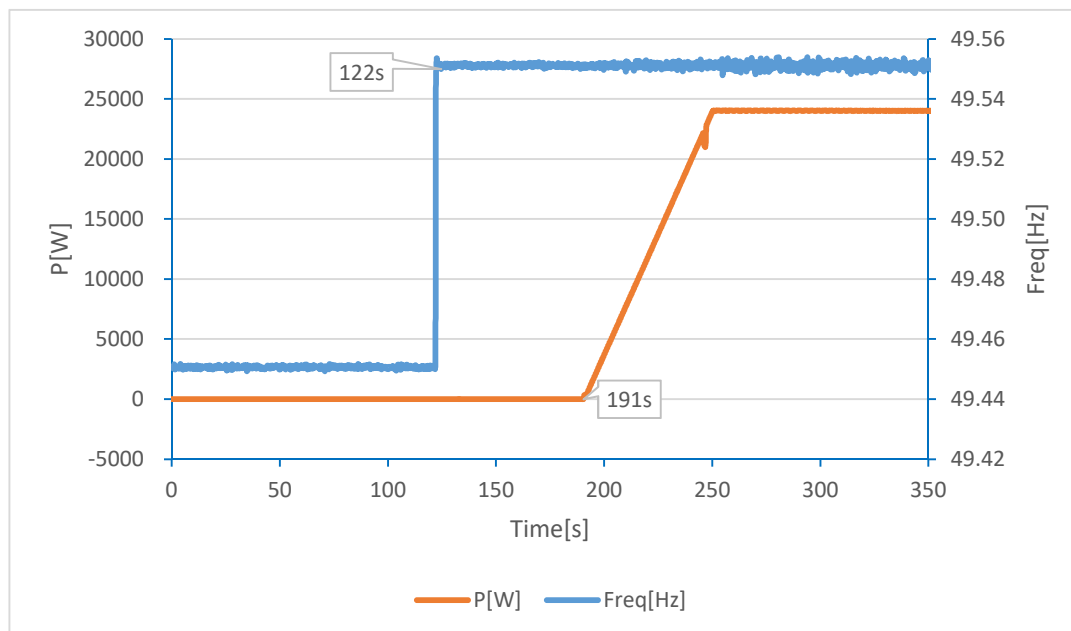
Graph of the gradual power supply : Test c) for  $\geq 85\% U_n$



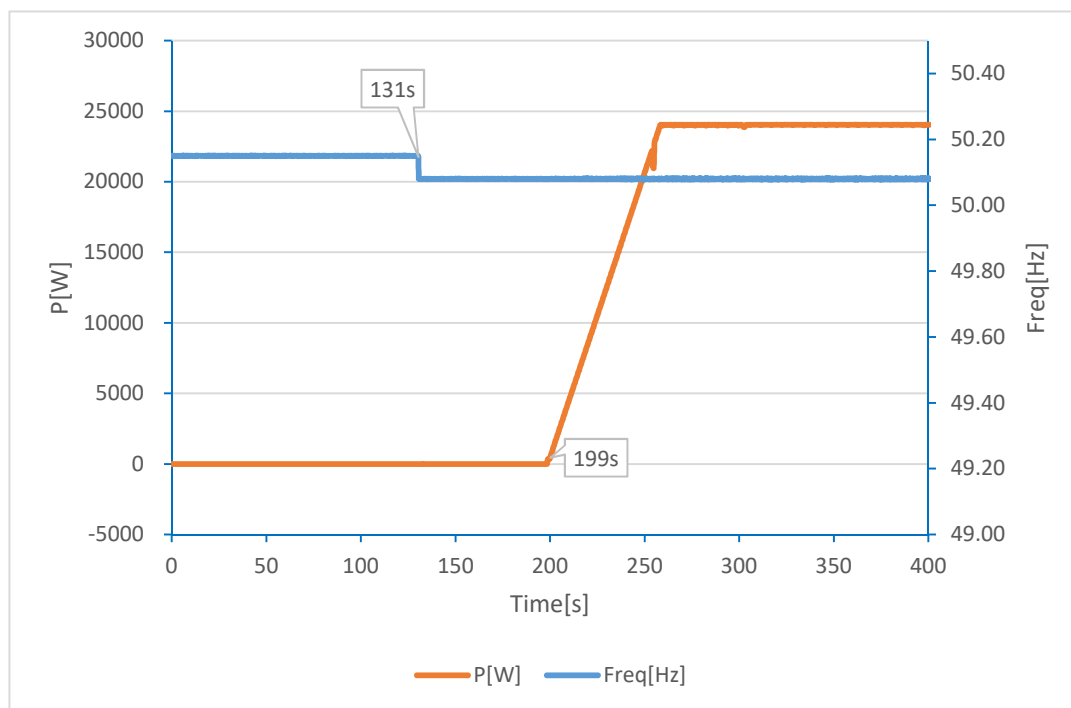
Graph of the gradual power supply : Test c) for  $\leq 110\% U_n$



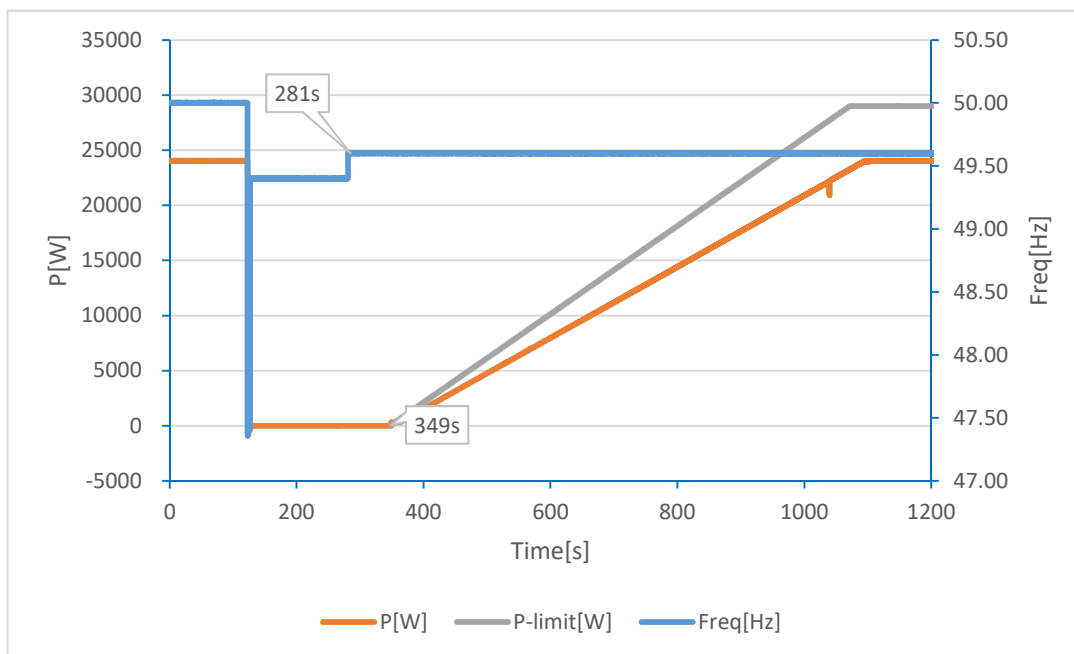
**Graph of the gradual power supply : Test e) for  $\geq 49,50\text{Hz}$**



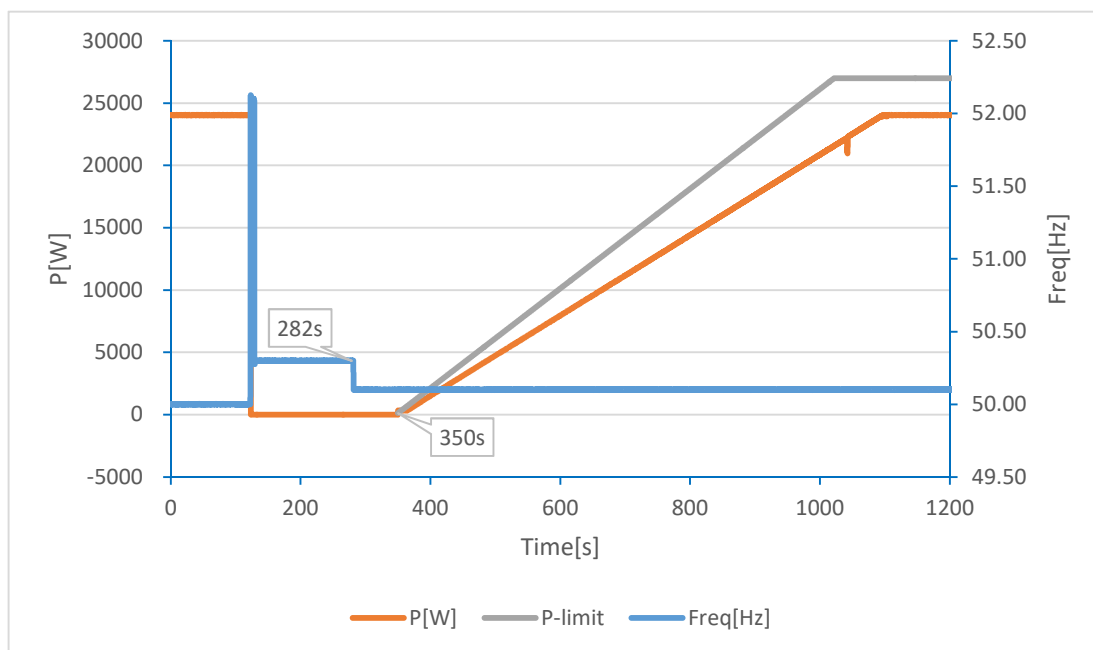
**Graph of the gradual power supply : Test e) for  $\leq 50,10\text{Hz}$**



Graph of the gradual power supply : Test f) for  $\geq 49,50\text{Hz}$



Graph of the gradual power supply : Test f) for  $\leq 50,20\text{Hz}$





### EN 50549-1:2019: Ceasing and reduction of active power on set point

Clause	Test requirement	Test procedure according standard	Result
4.11.1	Ceasing active power	CEI 0-21:2019-04, Annex A.4.3.3.2	<b>P</b>
4.11.2	Reduction of active power on a set point	FGW TG3, Revision 25, clause 4.1.2	<b>P</b>

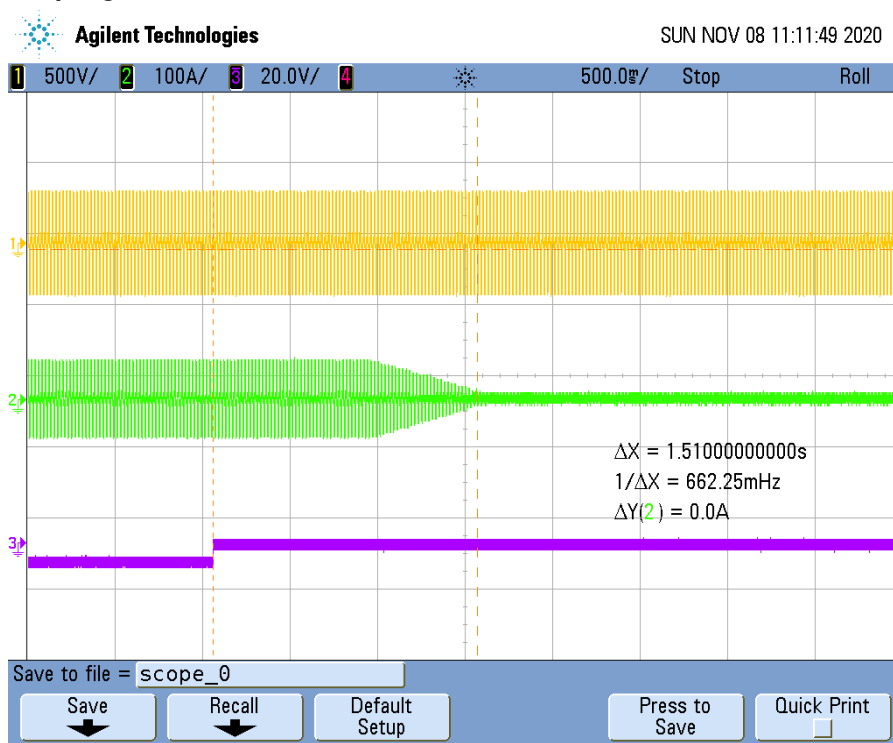
<b>4.11.1</b>	<b>Ceasing active power</b>	<b>P</b>
---------------	-----------------------------	----------

**Operating time of the monitoring device**

Test:	Remote tripping signal for the external disconnection
Limit [s]:	5 s
Reaction time of the tripping value [s]:	1,51 s

**Note:**  
 The test method refer to Annex A,4,3,2 of CEI 0-21:2019-04.  
 Generating plants shall be equipped with a logic interface (input port) in order to cease active power output within five seconds following an instruction being received at the input port, If required by the DSO, this includes remote operation.  
 The tests had been performed on the SOFAR 24KTLX-G3 is valid for the SOFAR 15KTLX-G3, SOFAR 17KTLX-G3, SOFAR 20KTLX-G3 and SOFAR 22KTLX-G3, since it is identical in hardware and software construction except output power derated by software.

**Graph of Remote trip signal :**



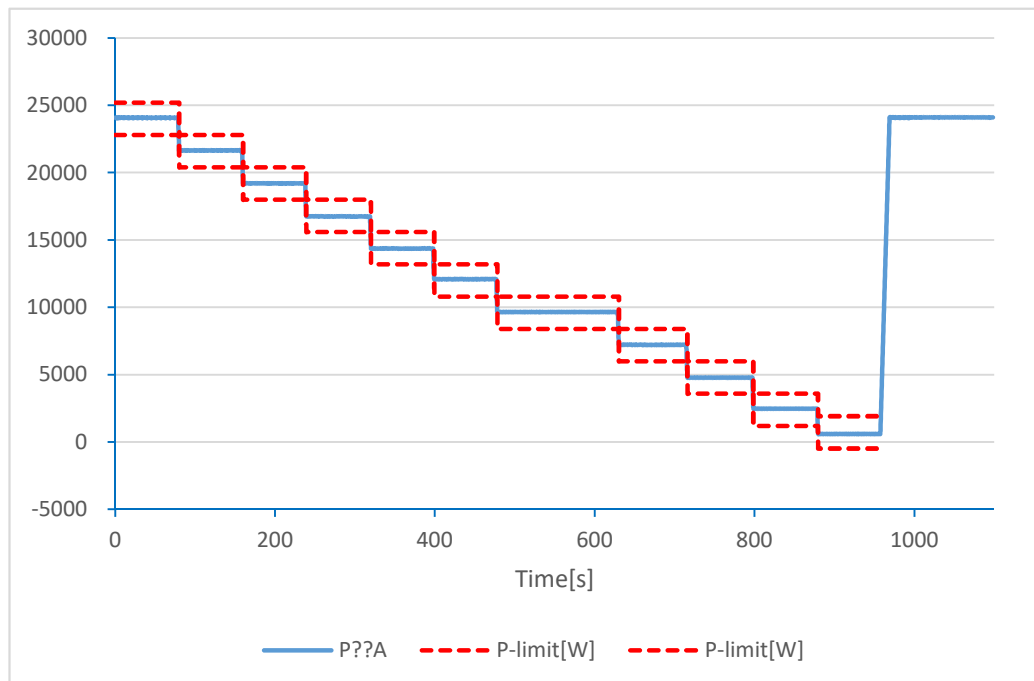
4.11.2 Reduction of active power on set point			P
<b>Test result:</b>			
Setpoint power bin [%P <sub>E<sub>max</sub></sub> ]	P <sub>set</sub> [kW]	P <sub>60</sub> [kW]	Deviation [%P <sub>E<sub>max</sub></sub> ]
100%	24,000	24,087	0,364
90%	21,600	21,644	0,185
80%	19,200	19,199	-0,003
70%	16,800	16,747	-0,221
60%	14,400	14,366	-0,140
50%	12,000	12,084	0,351
40%	9,600	9,648	0,201
30%	7,200	7,214	0,059
20%	4,800	4,773	-0,112
10%	2,400	2,462	0,260
3%	0,720	0,591	0,260
	Setpoint power bin [%P <sub>E<sub>max</sub></sub> ]	Deviation [%P <sub>E<sub>max</sub></sub> ]	
Max. deviation	100%	0,364	
<b>Limit <math>\Delta P_{E60}/P_{Setpoint}</math>:</b>	+ 5 % of P <sub>E<sub>max</sub></sub>		
<b>Test:</b>			
The setpoint signal must be reduced from 100% to 0% P <sub>E<sub>max</sub></sub> :			
a) for adjustable PGUs in increments of 10% P <sub>E<sub>max</sub></sub> , 1 minute must elapse after every change to the setpoint setting so that the PGU can settle at the new setpoint, Then the active power of the PGU must be measured as a 1-min mean value.			
b) For all other PGUs, in line with their adjustable steps, 5 minutes must elapse after the setpoint setting is changed so that the PGU can settle at the new setpoint, Then the active power of the PGU must be measured as a 1-min mean value.			
<b>Assessment criterion:</b>			
a) for adjustable PGUs:			
- no network disconnection			
- the active power value does not exceed the setpoint by more than 5% P <sub>E<sub>max</sub></sub>			
- the setting time determined this way is ≤ 1min			
b) For all other PGUs:			
- the active power value does not exceed the setpoint by more than 5% P <sub>E<sub>max</sub></sub> or			
- the setpoint is fallen below within 5 minutes or the PGU has switched off			

**Note:**

The setting time is  $\leq 1$  min. See below "Graph of the setting accuracy".

The tests had been performed on the SOFAR 24KTLX-G3 is valid for the SOFAR 15KTLX-G3, SOFAR 17KTLX-G3, SOFAR 20KTLX-G3 and SOFAR 22KTLX-G3, since it is identical in hardware and software construction except output power derated by software.

**Graph of active power on set point**



## EN 50549-1:2019

Clause	Test requirement	Test procedure according standard	Result
4.13	Requirements regarding single fault tolerance of interface protection system and interface switch	VDE V 0124-100:2019-02 (Draft), clause 5.5.2	<b>P</b>

4.13 Requirements regarding single fault tolerance of interface protection system and interface switch								P
Component No.	Fault	Test condition		Test time	Fuse No.	Fault condition		Result
		AC	DC			AC	DC	
PV inverter current monitoring defect R3	Short	230V 35A	850V 29A	10min.	--	230V 0,1A	850V <1A	Inverter disconnected from grid immediately. Error message:" HwPVOCP".  No damaged. No hazard.
PV current monitoring defect R852	Short	230V 35A	850V 29A	10min.	--	230V <1A	850V <1A	Inverter disconnected from grid immediately. Error message:" HwPVOCP".  No damaged.No hazard
PV inverter current monitoring defect U1 pin1-3	Short	230V 35A	850V 29A	10min.	--	230V <1A	850V <1A	Inverter disconnected from grid immediately. Error message:" HwPVOCP".  No damaged.No hazard.
Relay detect RL1	Short before start-up	230V <1A	850V <1A	10min.	--	230V <1A	850V <1A	Inverter did not start-up. Error message:" RelayTestFail".  No damage.No hazard.
Relay detect RL2	Short before start-up	230V <1A	850V <1A	10min.	--	230V <1A	850V <1A	Inverter did not start-up. Error message:" RelayTestFail".  No damage.No hazard.
Relay detect RL3	Short before start-up	230V <1A	850V <1A	10min.	--	230V <1A	850V <1A	Inverter did not start-up. Error message:" RelayTestFail".  No damage.No hazard.
Relay detect RL4	Short before start-up	230V <1A	850V <1A	10min.	--	230V <1A	850V <1A	Inverter did not start-up. Error message:" RelayTestFail".  No damage.No hazard.

Component No.	Fault	Test condition		Test time	Fuse No.	Fault condition		Result
		AC	DC			AC	DC	
Relay detect RL5	Short before start-up	230V <1A	850V <1A	10min.	--	230V <1A	850V <1A	Inverter did not start-up. Error message:" RelayTestFail". No damage.No hazard.
Relay detect RL6	Short before start-up	230V <1A	850V <1A	10min.	--	230V <1A	850V <1A	Inverter did not start-up. Error message:" RelayTestFail". No damage.No hazard.
AC Voltage monitoring defect R56	Open	230V 35A	850V 29A	10min.	--	230V <1A	850V <1A	Inverter disconnected from grid immediately. Error message:" GridUVP". No damaged.No hazard.
AC Voltage monitoring defect R58	Short	230V 35A	850V 29A	10min.	--	230V <1A	850V <1A	Inverter disconnected from grid immediately. Error message:" GridOVP". No damaged.No hazard.
AC Voltage monitoring defect R95	Open	230V 35A	850V 29A	10min.	--	230V <1A	850V <1A	Inverter disconnected from grid immediately. Error message:" GridUVP". No damaged.No hazard.
AC Voltage monitoring defect R96	Open	230V 35A	850V 29A	10min.	--	230V <1A	850V <1A	Inverter disconnected from grid immediately. Error message:" GridUVP". No damaged.No hazard.
AC Voltage monitoring defect R97	Open	230V 35A	850V 29A	10min.	--	230V <1A	850V <1A	Inverter disconnected from grid immediately. Error message:" GridUVP". No damaged.No hazard.
AC Voltage monitoring defect R101	Short	230V 35A	850V 29A	10min.	--	230V <1A	850V <1A	Inverter disconnected from grid immediately. Error message:" GridOVP". No damaged.No hazard.

Component No.	Fault	Test condition		Test time	Fuse No.	Fault condition		Result
		AC	DC			AC	DC	
AC Voltage monitoring defect R102	Short	230V 35A	850V 29A	10min.	--	230V <1A	850V <1A	Inverter disconnected from grid immediately. Error message:" GridOVP".  No damaged.No hazard.
AC Voltage monitoring defect R103	Short	230V 35A	850V 29A	10min.	--	230V <1A	850V <1A	Inverter disconnected from grid immediately. Error message:" GridOVP".  No damaged.No hazard.
ISO detect R168	short before start-up	230V 0,1A	850V 0,1A	10min.	--	230V <1A	850V <1A	Inverter disconnected from grid immediately. Error message:" IsoFault".  No damaged.No hazard.
ISO detect R169	short before start-up	230V 0,1A	850V 0,1A	10min.	--	230V <1A	850V <1A	Inverter disconnected from grid immediately. Error message:" IsoFault".  No damaged.No hazard.
ISO detect R22	Open before start-up	230V 0,1A	850V 0,1A	10min.	--	230V <1A	850V <1A	Inverter disconnected from grid immediately. Error message:" IsoFault".  No damaged.No hazard.
ISO detect R23	short before start-up	230V 0,1A	850V 0,1A	10min.	--	230V <1A	850V <1A	Inverter disconnected from grid immediately. Error message:" IsoFault".  No damaged.No hazard.
ISO detect R186	Open before start-up	230V 35A	850V 29A	10min.	--	230V <1A	850V <1A	Inverter disconnected from grid immediately. Error message:" IsoFault".  No damaged.No hazard.
ISO detect R188	Short before start-up	230V 35A	850V 29A	10min.	--	230V <1A	850V <1A	Inverter disconnected from grid immediately. Error message:" IsoFault".  No damaged.No hazard.



Component No.	Fault	Test condition		Test time	Fuse No.	Fault condition		Result
		AC	DC			AC	DC	
ISO detect R193	Open before start-up	230V 35A	850V 29A	10min.	--	230V <1A	850V <1A	Inverter disconnected from grid immediately. Error message:" IsoFault".  No damaged.No hazard.
ISO detect R194	Short before start-up	230V 35A	850V 29A	10min.	--	230V <1A	850V <1A	Inverter disconnected from grid immediately. Error message:" IsoFault".  No damaged.No hazard.
ISO detect R174	Open	230V 35A	850V 29A	10min.	--	230V <1A	850V <1A	Inverter disconnected from grid immediately. Error message:" IsoFault".  No damaged.No hazard.
ISO detect R175	Short before start-up	230V 35A	850V 29A	10min.	--	230V <1A	850V <1A	Inverter disconnected from grid immediately. Error message:" IsoFault".  No damaged.No hazard.
ISO detect R212	Open before start-up	230V 35A	850V 29A	10min.	--	230V <1A	850V <1A	Inverter disconnected from grid immediately. Error message:" IsoFault".  No damaged.No hazard.
ISO detect R207	Short before start-up	230V 35A	850V 29A	10min.	--	230V 35A	850V 29A	Inverter disconnected from grid immediately. Error message:" IsoFault".  No damaged.No hazard.
GFCI monitoring defect R421	Open	230V 35A	850V 29A	10min.	--	230V <1A	850V <1A	Inverter disconnected from grid immediately. Error message:" AFCIFault".  No damaged.No hazard.
GFCI protect R426	Open	230V 35A	850V 29A	10min.	--	230V <1A	850V <1A	Inverter disconnected from grid immediately. Error message:" AFCIFault".  No damaged.No hazard.

Component No.	Fault	Test condition		Test time	Fuse No.	Fault condition		Result
		AC	DC			AC	DC	
GFCI protect C275	Short	230V 35A	850V 29A	10min.	--	230V <1A	850V <1A	Inverter disconnected from grid immediately. Error message:" AFCIFault".  No damaged.No hazard.
GFCI protect C270	Short	230V 35A	850V 29A	10min.	--	230V <1A	850V <1A	Inverter disconnected from grid immediately. Error message:" AFCIFault".  No damaged.No hazard.
GFCI protect R413	Short	230V 35A	850V 29A	10min.	--	230V <1A	850V <1A	Inverter disconnected from grid immediately. Error message:" AFCIFault".  No damaged.No hazard.
GFCI protect U5-D pin12-14	Short	230V 35A	850V 29A	10min.	--	230V <1A	850V <1A	Inverter disconnected from grid immediately. Error message:" AFCIFault".  No damaged.No hazard.
GFCI protect U5-C pin10-8	Short	230V 35A	850V 29A	10min.	--	230V <1A	850V <1A	Inverter disconnected from grid immediately. Error message:" AFCIFault".  No damaged.No hazard.
GFCI protect C252	Short	230V 35A	850V 29A	10min.	--	230V <1A	850V <1A	Inverter disconnected from grid immediately. Error message:" AFCIFault".  No damaged.No hazard.
GFCI protect R411	Short	230V 35A	850V 29A	10min.	--	230V <1A	850V <1A	Inverter disconnected from grid immediately. Error message:" AFCIFault".  No damaged.No hazard.
PV voltage monitor defect R515	Short	230V 35A	850V 29A	10min.	--	230V <1A	850V <1A	Inverter disconnected from grid immediately. Error message:" InvOVP" No damaged.No hazard.
PV voltage monitor defect R517	Open	230V 17A	850V 15A	10min.	--	230V <1A	850V <1A	Inverter disconnected from grid immediately. Error message:" InvUVP" No damaged.No hazard.

Component No.	Fault	Test condition		Test time	Fuse No.	Fault condition		Result
		AC	DC			AC	DC	
PV voltage monitor defect R522	Short	230V 35A	850V 29A	10min.	--	230V <1A	850V <1A	Inverter disconnected from grid immediately. Error message:" InvOVP" No damaged.No hazard.
PV voltage monitor defect R524	Open	230V 17A	850V 15A	10min.	--	230V <1A	850V <1A	Inverter disconnected from grid immediately. Error message:" InvUVP" No damaged.No hazard.
PV voltage monitor defect R529	Short	230V 35A	850V 29A	10min.	--	230V <1A	850V <1A	Inverter disconnected from grid immediately. Error message:" InvOVP" No damaged.No hazard.
PV voltage monitor defect R531	Open	230V 17A	850V 15A	10min.	--	230V <1A	850V <1A	Inverter disconnected from grid immediately. Error message:" InvUVP"  No damaged.No hazard.
PV voltage monitor defect R538	Short	230V 35A	850V 29A	10min.	--	230V <1A	850V <1A	Inverter disconnected from grid immediately. Error message:" InvOVP" No damaged.No hazard.
PV voltage monitor defect R540	Open	230V 17A	850V 15A	10min.	--	230V <1A	850V <1A	Inverter disconnected from grid immediately. Error message:" InvUVP" No damaged.No hazard.
Bus voltage detect R547	Short	230V 35A	850V 29A	10min.	--	230V <1A	850V <1A	Inverter disconnected from grid immediately. Error message:" VbusRmsUnbalance".  No damaged.No hazard.
Bus voltage detect R549	Open	230V 35A	850V 29A	10min.	--	230V <1A	850V <1A	Inverter disconnected from grid immediately. Error message:" VbusRmsUnbalance".  No damaged.No hazard.
Bus voltage detect R552	Short	230V 35A	850V 29A	10min.	--	230V <1A	850V <1A	Inverter disconnected from grid immediately. Error message:" VbusRmsUnbalance".  No damaged.No hazard.

Component No.	Fault	Test condition		Test time	Fuse No.	Fault condition		Result
		AC	DC			AC	DC	
Bus voltage detect R554	Open	230V 35A	850V 29A	10min.	--	230V <1A	850V <1A	Inverter disconnected from grid immediately. Error message:" VbusRmsUnbalance".  No damaged.No hazard.
Bus voltage detect R557	Short	230V 35A	850V 29A	10min.	--	230V <1A	850V <1A	Inverter disconnected from grid immediately. Error message:" VbusRmsUnbalance".  No damaged.No hazard.
Bus voltage detect R559	Open	230V 35A	850V 29A	10min.	--	230V <1A	850V <1A	Inverter disconnected from grid immediately. Error message:" VbusRmsUnbalance".  No damaged.No hazard.
Bus voltage detect R562	Short	230V 35A	850V 29A	10min.	--	230V <1A	850V <1A	Inverter disconnected from grid immediately. Error message:" VbusRmsUnbalance".  No damaged.No hazard.
Bus voltage detect R564	Open	230V 35A	850V 29A	10min.	--	230V <1A	850V <1A	Inverter disconnected from grid immediately. Error message:" VbusRmsUnbalance".  No damaged.No hazard.
Grid voltage monitor defect R601	Open	230V 35A	850V 29A	10min.	--	230V <1A	850V <1A	Inverter disconnected from grid immediately. Error message:" GridUVP".  No damaged.No hazard.
Grid voltage monitor defect R602	Short	230V 35A	850V 29A	10min.	--	230V <1A	850V <1A	Inverter disconnected from grid immediately. Error message:" GridOVP".  No damaged.No hazard.
Grid voltage monitor defect R589	Short	230V 35A	850V 29A	10min.	--	230V <1A	850V <1A	Inverter disconnected from grid immediately. Error message:" GridOVP".  No damaged.No hazard.

Component No.	Fault	Test condition		Test time	Fuse No.	Fault condition		Result
		AC	DC			AC	DC	
Grid voltage monitor defect R590	Short	230V 35A	850V 29A	10min.	--	230V <1A	850V <1A	Inverter disconnected from grid immediately. Error message:" GridUVP".  No damaged.No hazard.
Grid voltage monitor defect R597	Short	230V 35A	850V 29A	10min.	--	230V <1A	850V <1A	Inverter disconnected from grid immediately. Error message:" GridOVP".  No damaged.No hazard.
Grid voltage monitor defect R596	Short	230V 35A	850V 29A	10min.	--	230V <1A	850V <1A	Inverter disconnected from grid immediately. Error message:" GridUVP".  No damaged.No hazard.
Grid voltage monitor defect R569	Short	230V 35A	850V 29A	10min.	--	230V <1A	850V <1A	Inverter disconnected from grid immediately. Error message:" GridOVP".  No damaged.No hazard.
Grid voltage monitor defect R836	Short	230V 35A	850V 29A	10min.	--	230V <1A	850V <1A	Inverter disconnected from grid immediately. Error message:" GridUVP".  No damaged.No hazard.
Grid voltage monitor defect R574	Short	230V 35A	850V 29A	10min.	--	230V <1A	850V <1A	Inverter disconnected from grid immediately. Error message:" GridOVP".  No damaged.No hazard.
Grid voltage monitor defect R839	Short	230V 35A	850V 29A	10min.	--	230V <1A	850V <1A	Inverter disconnected from grid immediately. Error message:" GridUVP".  No damaged.No hazard.
Grid voltage monitor defect R578	Short	230V 35A	850V 29A	10min.	--	230V <1A	850V <1A	Inverter disconnected from grid immediately. Error message:" GridOVP".  No damaged.No hazard.

Component No.	Fault	Test condition		Test time	Fuse No.	Fault condition		Result
		AC	DC			AC	DC	
Grid voltage monitor defect R841	Short	230V 35A	850V 29A	10min.	--	230V <1A	850V <1A	Inverter disconnected from grid immediately. Error message:" GridUVP".  No damaged.No hazard.
Grid voltage monitor defect R583	Short	230V 35A	850V 29A	10min.	--	230V <1A	850V <1A	Inverter disconnected from grid immediately. Error message:" GridOVP".  No damaged.No hazard.
Grid voltage monitor defect R587	Short	230V 35A	850V 29A	10min.	--	230V <1A	850V <1A	Inverter disconnected from grid immediately. Error message:" GridUVP".  No damaged.No hazard.
BUS voltage monitoring defect R613	Open	230V 35A	850V 29A	10min.	--	230V <1A	850V <1A	Inverter disconnected from grid immediately. Error message:" BUS voltage is low".  No damaged.No hazard.
BUS voltage monitoring defect R614	Short	230V 35A	850V 29A	10min.	--	230V <1A	850V <1A	Inverter disconnected from grid immediately. Error message:" Inverter bus hardware overvoltage".  No damaged.No hazard.
ISO monitoring defect R189	Open before start-up	230V <1A	850V <1A	10min.	--	230V <1A	850V <1A	Inverter disconnected from grid immediately. Error message:" IsoFault".  No damaged.No hazard.
ISO monitoring defect R510	Short before start-up	230V <1A	850V <1A	10min.	--	230V <1A	850V <1A	Inverter disconnected from grid immediately. Error message:" IsoFault".  No damaged.No hazard.
ISO monitoring defect R799	Open before start-up	230V <1A	850V <1A	10min.	--	230V <1A	850V <1A	Inverter disconnected from grid immediately. Error message:" IsoFault".  No damaged.No hazard.

Component No.	Fault	Test condition		Test time	Fuse No.	Fault condition		Result
		AC	DC			AC	DC	
ISO monitoring defect R801	Short before start-up	230V <1A	850V <1A	10min.	--	230V <1A	850V <1A	Inverter disconnected from grid immediately. Error message:" IsoFault".  No damaged.No hazard.
Communication defect U13 pin82	Open	230V 35A	850V 29A	10min.	--	230V <1A	850V <1A	Inverter disconnected from grid immediately. Error message:" BluetoothFault".  No damaged.No hazard.
Communication defect U13 pin95	Open	230V 35A	850V 29A	10min.	--	230V <1A	850V <1A	Inverter disconnected from grid immediately. Error message:" BluetoothFault".  No damaged.No hazard.
The errors in the control circuit simulate that the safety is even under one error ensured,								
<b>Addendum – Shutdown device</b>								
Each active phase can be switched, (L and N)								Yes
If no galvanic separation between AC and DC (PV): Two relays in series on each active phase are necessary to fulfil the basic insulation or simple separation based on the PV working voltage,								Two relays in series on each active phase
<b>Note:</b> The tests had been performed on the SOFAR 24KTLX-G3 is valid for the SOFAR 15KTLX-G3, SOFAR 17KTLX-G3, SOFAR 20KTLX-G3 and SOFAR 22KTLX-G3, since it is identical in hardware and software construction except output power derated by software.								



Report No.: PVIR200511N080-2

# Annex No. 1

## Pictures of the unit



### Enclosure front view



### Enclosure side view



**Enclosure bottom view  
SOFAR 15KTLX-G3, SOFAR 17KTLX-G3**



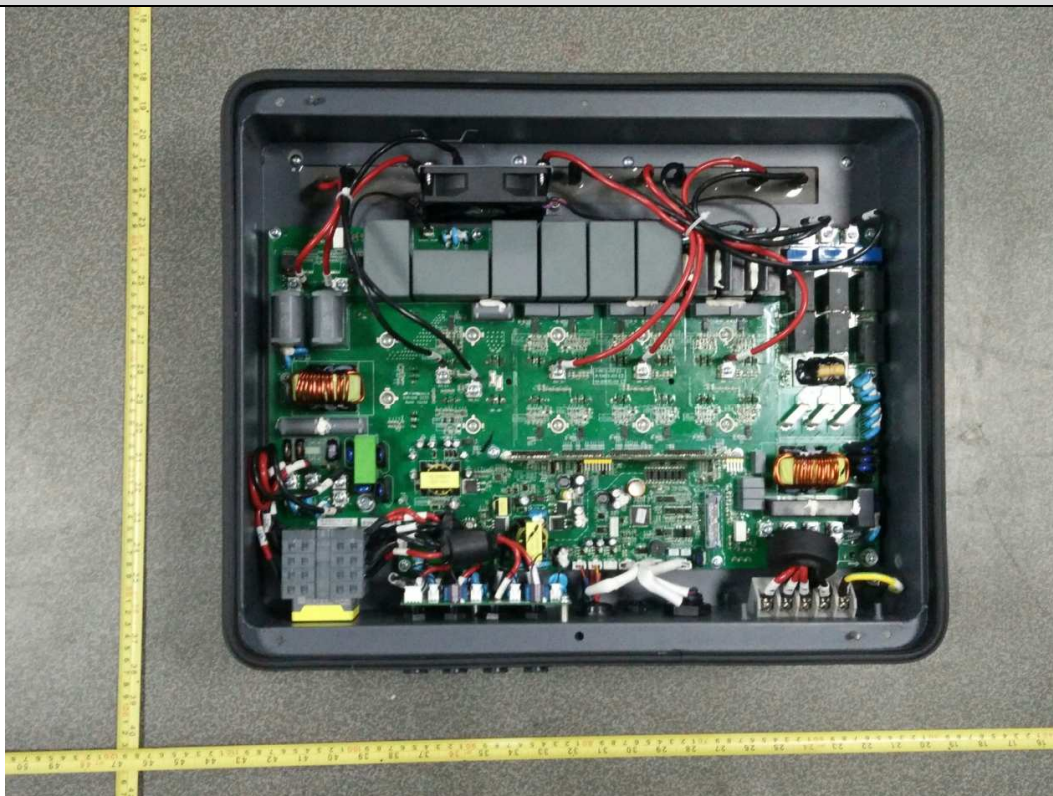
**Enclosure bottom view  
SOFAR 20KTLX-G3, SOFAR 22KTLX-G3, SOFAR 24KTLX-G3**



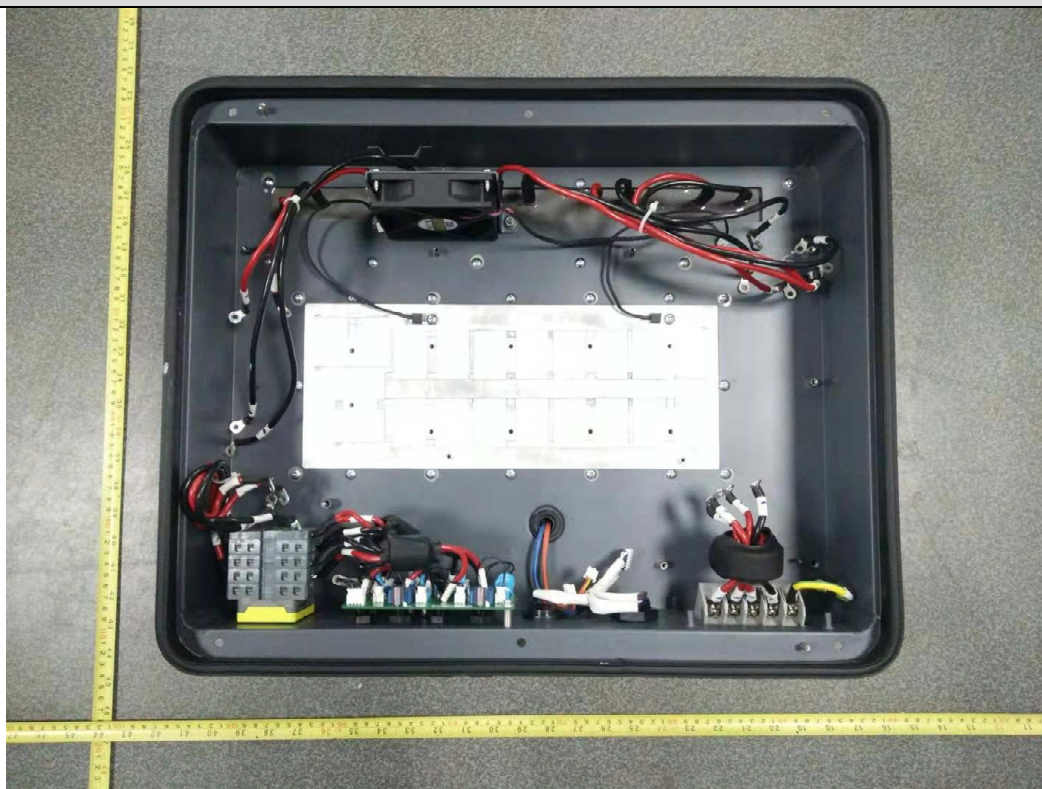
### Enclosure rear view



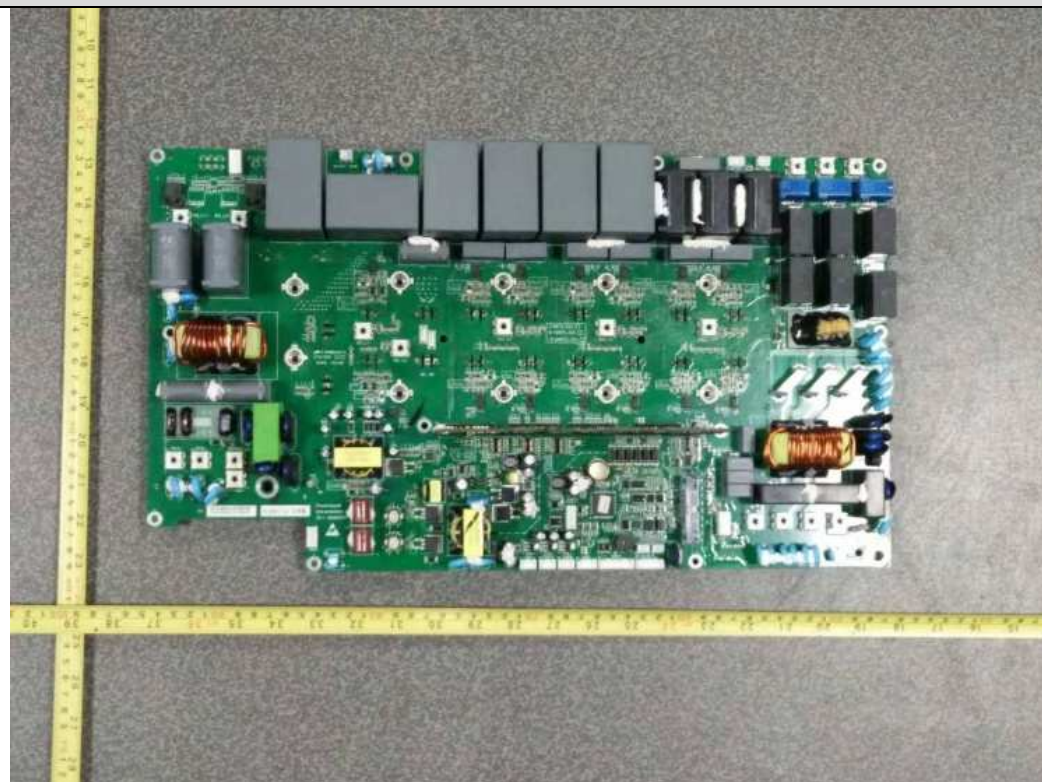
### Internal view



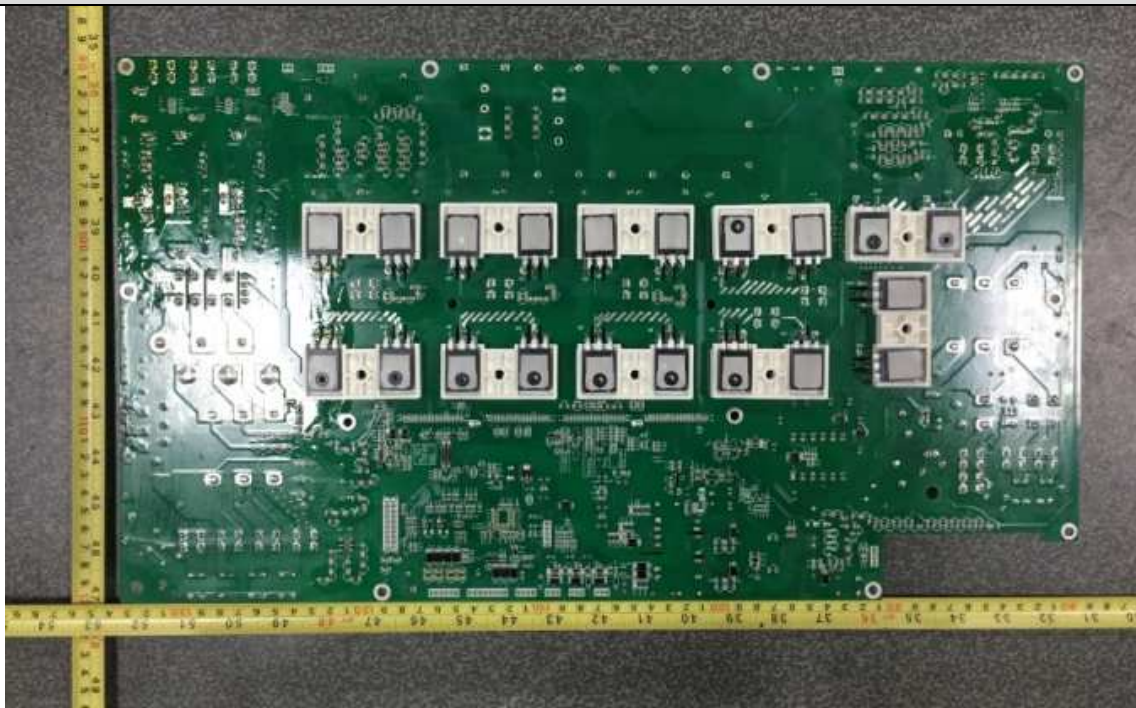
### Internal view



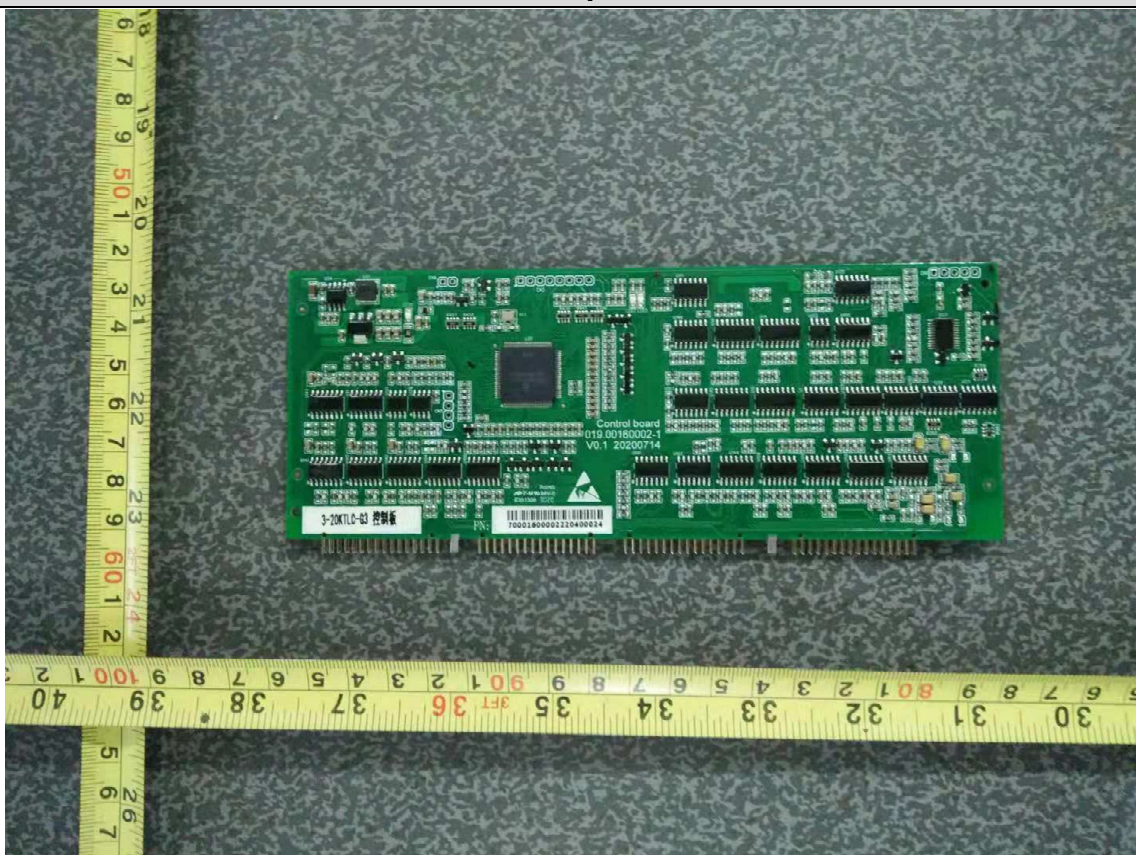
### Power board component side view



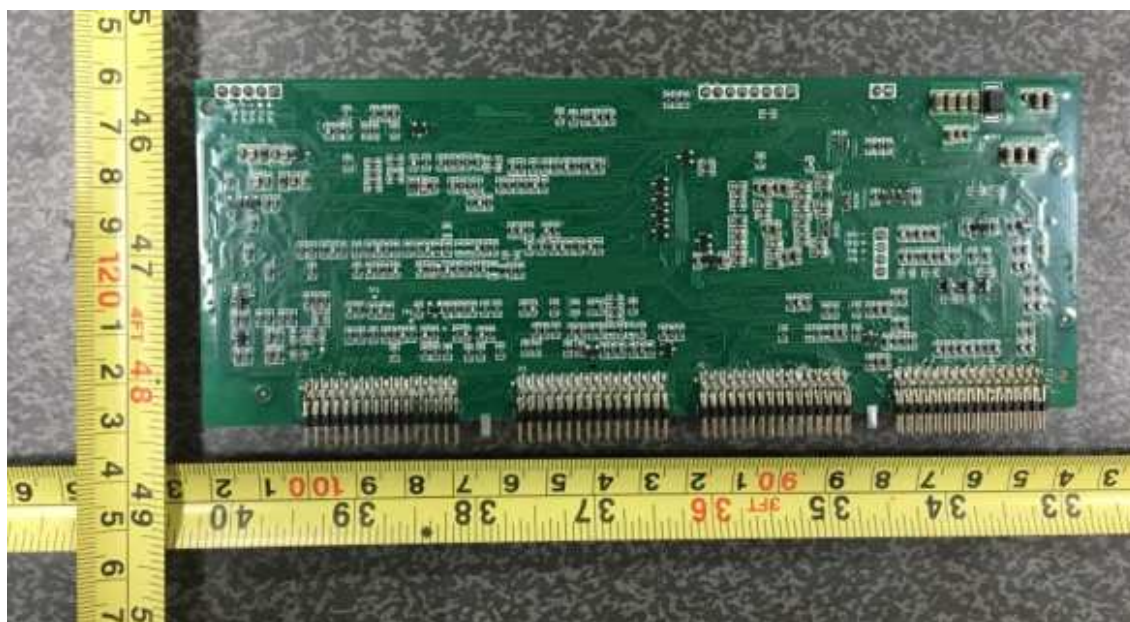
### Power board solder side view



### Control board component side view



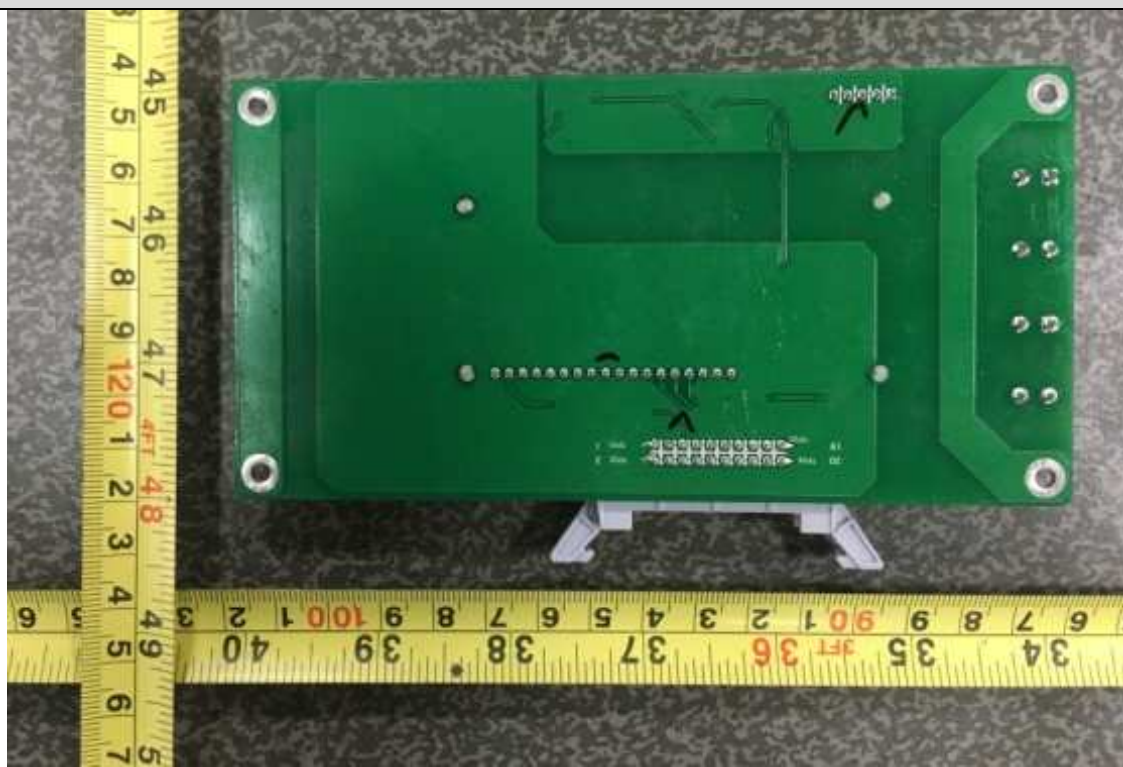
### Control board solder side view



### LCD board component side view



LCD board solder side view



General view of Grouding point





Report No.: PVIR200511N080-2

# Annex No. 2

## Test Equipment list



**Dates of performance test: 2020-06-01 to 2020-12-18**

Equipment	Internal No.	Manufacturer	Type	Serial No.	Next Calibration date
Power Analyser	A4080002DG	YOKOGAWA	WT3000	91M210852	Jun. 16, 2021
AC Source	A7040019DG	Chroma	61512	61512000439	Monitored by Power Analyser
	A7040020DG	Chroma	61512	61512000438	
DC Simulation Power Supply	A7040015DG	Chroma	62150H-1000S	62150EF00488	
	A7040016DG	Chroma	62150H-1000S	62150EF00490	
	A7040017DG	Chroma	620028	620028EF00120	
RLC Load	A7150027DG	Qunling	ACLT-3803H	93VOO2869	
Eight Channel Digital Phosphor Oscilloscope	A4089017DG	YOKOGAWA	DL850	91N726247	Sep. 24, 2020
Oscilloscope probe	A4089008DG	Tektronix	TPP1000	C008230	Aug. 10, 2021
	A4089010DG	Tektronix	TPP1000	C008228	Aug. 10, 2021
	A4089011DG	Tektronix	TPP1000	C008229	Aug. 10, 2021
Current transducer	A1060007DG	YOKOGAWA	CT200	1130700012	Sep. 02, 2021
	A1060008DG	YOKOGAWA	CT200	1130700017	Sep. 02, 2021
	A1060012DG	YOKOGAWA	CT200	1130700018	Sep. 02, 2021
Power Analyser	//	ZLG	PA5000H	C820290908200 2110001	Mar. 02, 2021
Oscilloscope	//	Agilent	DS05014A	MY50070288	Jan. 13, 2021
Oscilloscope current probe	//	CYBERTEK	CP1000A	C181000922	Jan. 13, 2021
	//	CYBERTEK	CP1000A	C181000925	Jan. 13, 2021
	//	CYBERTEK	CP1000A	C181000929	Jan. 13, 2021
	//	CYBERTEK	CP1000A	C181000931	Jan. 13, 2021
Oscilloscope probe	//	SANHUA	SI-9110	152627	Jan. 13, 2021
	//	SIALENT	DS5034X	SDS5XEAC3R0 011	Jan. 13, 2021
	//	AGILENT	N2863B	YF0139	Jan. 13, 2021